

FIS GAS SENSOR SP3S-AQ2-01

for AIR QUALITY CONTROLS(VOCs)

The SP3S-AQ2-01 series is a tin dioxide semiconductor gas sensor which has a high sensitivity to various air pollution sources (e.g.VOCs) with quick response speed. This series uses a compact plastic housing with 3 pins configuration achieving an excellent gas sensing performance with low cost. This model is ideal for various design of automatic air quality control systems ; Ventilation Fans , air purifiers.

Structure

Gas sensitive semiconductor material is formed on the alumina substrate on which the gold electrodes are printed. A thick film heater of ruthenium oxide is printed on the reverse of the substrate and placed in the compact plastic housing (Fig 1).

Operating conditions

Fig 2 shows the standard operating circuit for this model. The change of the sensor resistance (R_S) is obtained as the change of the output voltage across the fixed or variable resistor (R_L). In order to obtain the best performance and specified characteristics, the values of the heater voltage (V_H) circuit voltage (V_C) and load resistance (R_L) must be within the range of values given in the Specification table on the next page.

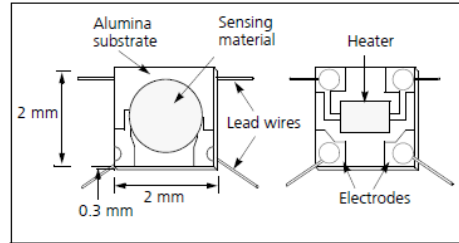

Fig 1a. Sensing element

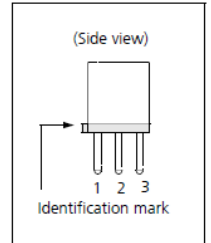

Fig 1c. Pin Layout

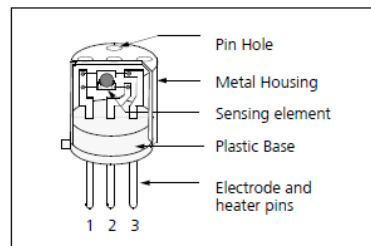

Fig 1b. Configuration

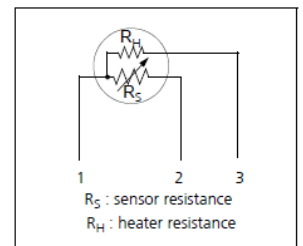

Fig 1d. Equivalent circuit

Sensitivity characteristics

Fig 3 shows the sensitivity characteristics curves of the SP3S-AQ2-01 (typical data). Sensitivity characteristics of our gas sensors are expressed by the relationship between the sensor resistance and gas concentration. The sensor resistance decreases with an increase of gas concentration based on a logarithmic function.

The sensitivity characteristics of the SP3S-AQ2-01 are specified by the following parameters.

- Sensor resistance level: in air
- Sensor resistance change ratio: between hydrogen 10 ppm and in air.

Please see the Specification table on the back page for further details.

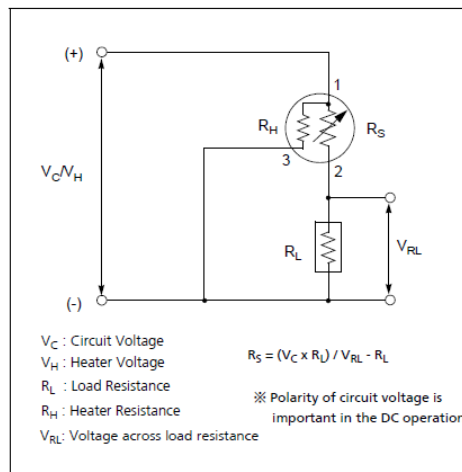

Fig 2. Standard circuit

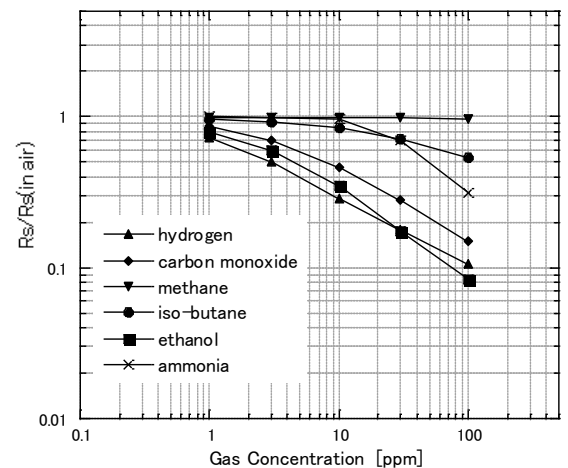

Fig 3. Sensitivity characteristics

SP3S-AQ2-01

Specifications: SP3S-AQ2-01

A. Standard Operating conditions

Symbol	Parameter	Specification	Conditions etc.
VH	Heater voltage	5.0 V ± 4%	AC or DC
VC	Circuit voltage	5.0 V ± 4%	AC or DC
RL	Load resistance	Variable	Ps < 10 mW
RH	Heater resistance	86 Ω ± 5%	at room temperature
IH	Heater current	42 mA (Typical value)	IH = VH / RH
PH	Heater power consumption	210 mW (Typical value)	PH = VH ² / RH
PS	Power dissipation of sensing element	Less than 15 mW	$P_s = \frac{(V_C - V_{RL})^2}{R}$

B. Environmental conditions

Symbol	Parameter	Specification	Conditions etc.
T _{ao}	Operating temperature	0 °C to 40 °C	
T _{as}	Storage temp	-20 °C to 60 °C	
RH	Relative humidity	Less than 95%RH	
(O ₂)	Oxygen concentration	21% ± 1% (Standard condition) The sensitivity characteristics are influenced by the variation in oxygen concentration. Please consult us for details.	Absolute minimum level: more than 18%.

C. Sensitivity characteristics

Model SP3S-AQ2-01			
Symbol	Parameter	Specification	Conditions etc.
R _s	Sensor resistance	5 k to 20kΩ	in air
β	Sensitivity	0.15 to 0.45	R _s in 10ppm hydrogen RS in air
Standard Test Conditions:		Temp: 20 °C ± 2 °C Humidity: 65% ± 5% (in clean air) Pre-heating time: more than 48 hours	VC: 5.0 ± 1% VH: 5.0 ± 1% RH: 10 kΩ ± 5%

D. Mechanical characteristics

Items	Conditions	Specifications
Vibration	Frequency: 100cpm Vertical amplitude: 4mm Duration: 1hour	Should satisfy the specifications shown in the C.Sensitivity characteristics after test.
Drop	Acceleration: 100 G Number of impacts: 5 times	

Dimensions

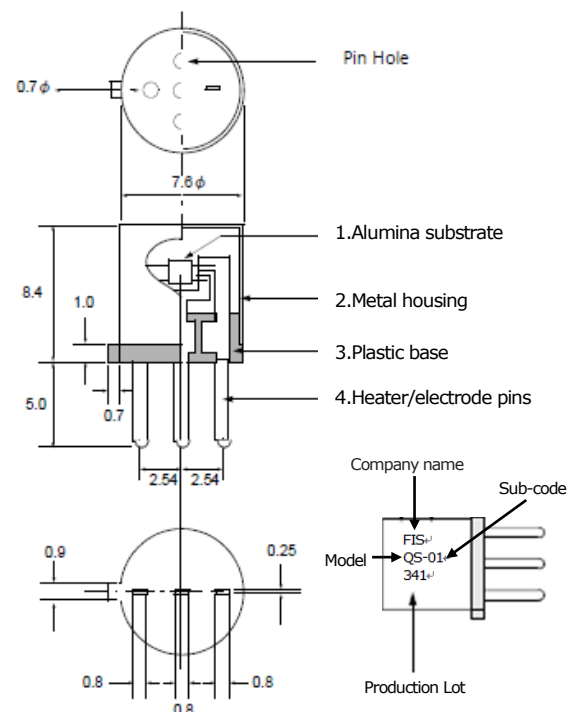

Scale: mm

Weight : 0.6g

E. Parts and Materials

No.	Parts	Materials
1	Alumina Substrate	Alumina (Al ₂ O ₃)
2	Metal housing	Nickel plated brass
3	Plastic base	PBT (Poly butylene terephthalate)
4	Heater/electrode pins	Iron-nickel alloy

Please contact

Dec. 2021 Revised

Nissha FIS, Inc.
2-4-28, Tagawa
Yodogawa, Osaka
532-0027 Japan

Tel: +81 6-7176-3911
Fax: +81 6-7176-3912
<http://www.fisinc.co.jp>

In the interest of continued product improvement, we reserve the right to change design features without prior notice.

@nissha