

Only for RAY5 20W

## User Manual V0

Dear customer,

Thank you for choosing LONGER products **RAY5**.

Maybe you are familiar with the engraving machine or have bought a similar engraving machine before, we still highly recommend that you read this manual carefully. The installation techniques and precautions in this manual can help you avoid any unnecessary damage or frustration.

More information please refer to:

1. Please contact us via email: [support@longer3d.com](mailto:support@longer3d.com).
2. Facebook page and YouTube channel as shown below.

Facebook : [Longer 3D Official Group](#)

YouTube Channel: [Longer 3D](#)

# Contents

A. Safety Precautions.....	1
B. Product Information.....	8
(1) Specifications.....	8
(2) Components Introduction .....	9
(3) Packing List .....	10
(4) Machine assembly.....	11
C. Machine Operation .....	16
(1) Focusing the Laser Module.....	16
(2) Power On .....	17
(3) Touch Screen Operation .....	17
(4) Wi-Fi Control operation .....	20
(5) LaserGRBL Software Operation .....	23
(6) LightBurn Software Operation.....	26
(7) Firmware Upgrading.....	31
(8) APP Operation .....	32
D. FAQ.....	39
Question 1: Are there recommended engraving and cutting parameters? ..	39
Question 2: The engraved pattern appears vibration, or is not closed? .....	39
Question 3: How about the warranty policy? .....	40
Question 4: How to maintain RAY5 laser module? .....	42
Question 5: How to solve alarm 2 error or hard limit? .....	43
Question 6: How to solve the upload error of the APP? .....	44

## A. Safety Precautions

(1) The **RAY5** engraves and cuts materials by the means of a high-energy diode laser beam.

The hazards associated with a high-energy diode laser beam include the possibility of fires, generation of hazardous and/or irritating toxic fumes, but more importantly damage to eyes and skin.

(2) Laser engravers are divided into several internationally valid classes based on their performance and the risk of injury. The **RAY5** falls into the Class IV (Class 4 IEC standard focus on the American FDA classification).

Laser class	Class Definition
Class I	Class I laser radiation is not considered hazardous.
Class IIa	Class IIa laser radiation is not considered hazardous if viewed for any period of time less than or equal to $1 \times 10^3$ seconds but is considered a chronic viewing hazard for any period of time greater than $1 \times 10^3$ seconds.
Class II	Class II laser radiation is considered a chronic viewing hazard.
Class IIIa	Class IIIa laser radiation is, depending upon the irradiance, either an acute in-trabeam viewing hazard or chronic viewing hazard. If viewed directly with optical instruments, Class IIIa laser radiation is classified as an acute viewing hazard.
Class IIIb	Direct Class IIIb laser radiation is considered an acute hazard to the skin and eyes.
Class IV	Class IV laser radiation is considered an acute hazard to the skin and eyes from both direct and scattered radiation.

The high energy laser beam can cause severe eye damage, including blindness and serious skin burns.

Improper use of the controls and modification of the safety features may cause serious eye injury and burns.

Please wear Personal Protective Equipment (PPE, Safety Glasses are designed to filter specific ranges of laser wavelength. The **RAY5** Safety Glasses provided are specific for LONGER Laser Module;) when using the machine.

- DO NOT look directly into the laser beam.
- DO NOT aim the laser beam at reflective surfaces.
- DO NOT operate the laser without PPE protection for all persons nearby in the proximity of the **RAY5**.
- DO NOT allow unsupervised access to the **RAY5** to children.
- DO NOT allow access near the **RAY5** to pets.
- DO NOT modify or disable any safety features of the laser system.
- DO NOT touch the high energy laser beam.

(3) We strongly recommend placing the machine in a well-ventilated room, and at the same time, the door of the room has a sealing effect, and the windows have curtains, to effectively avoid looking directly at the laser beam and some smoke and steam, Particles, and other highly toxic substances. At the same time, you can pay attention to the LONGER products (cover) in the follow-up.

(4) The high-energy diode laser beam can produce extremely high temperatures and significant amounts of heat as the substrate material is burned away while engraving and cutting. Some materials are prone to catch fire during cutting operations creating flame, fumes, and smoke.

(5) Although the **RAY5** has a built-in flame sensor, this technology should NOT be considered 100% accurate and should be seen only as a warning system.

During the working process of **RAY5**, if a flame is found, the machine will stop the laser and make a sound to indicate abnormal conditions. Please pay attention to the working status of the machine.

during operation to ensure that any flare ups/ flame is properly contained and extinguished.

It is strongly recommended that a Fire Extinguisher should be located within proximity to the **RAY5**. Extinguishers should be halogen or multi-purpose dry chemical. Alternatively, or in conjunction with the Fire Extinguisher it is recommended a “Fire Extinguisher Ball” is positioned beside the **RAY5**.

- DO NOT use materials that are highly flammable, explosive or produce toxic by-products.

- DO NOT remove material from the cutting bed before it has cooled.
- DO NOT leave the **RAY5** operating unattended.
- ALWAYS clean up clutter, debris, and flammable materials in the laser **RAY5** bed after use.
- ALWAYS keep a properly maintained fire extinguisher nearby.
- DO NOT allow the USB cable to contact with the laser Beam.
- DO NOT allow the 24V power cable to contact with the laser Beam.

(6) During the engraving process of the **RAY5** laser engraving machine, different materials may produce different pungent odors. Always use **RAY5** laser engravers in open and well-ventilated areas.

#### (7) Environmental requirements

Temperature requirement: 10° C~30° C, humidity requirement: 20%~50%, this **RAY5** laser engravers can work normally within this range; beyond this range, this laser engravers will be unable to achieve the best engraving results.

(8) Below a list of some of the most known hazardous materials that the user SHOULD NOT attempt to engrave or cut on. If a material is not in this list, do not consider it to be safe to use. Obtain the

Safety Data Sheet (SDS) from the material’s manufacturer when handling unknown materials.

Material	Reason to avoid engraving / cutting it
PVC (Poly Vinyl Chloride)	PVC will emit Chlorine gas when laser cut, or laser engraved. This toxic gas can ruin the optics and motion control system of the laser engraver, in fact, engraving or cutting PVC is a sure way of voiding the warranty of your laser engraver
Lexan / Thick Poly-carbonate	Lexan not only cuts poorly but it also catches on fire very easily. The window of the laser engraving machine is usually made from polycarbonate because it does a very good job of attracting infrared radiation., which is the frequency of light the engraver uses when cutting and engraving materials. This makes the laser cutter quite ineffective in cutting polycarbonate materials
ABS	ABS melts upon exposure to a laser beam as opposed to vaporizing which would be the ideal reaction needed for laser engraving. Instead of leaving a crisp image, ABS will melt and leave a goeoy deposit on the surface.
HDPE	HDPE melts and catches on fire easily upon exposure to a laser beam.
Polystyrene Foam	Only very thin pieces can be laser cut but for the most part, polystyrene catches on fire and melts when exposed to a laser beam
Fiberglass	Fiberglass is made from two materials: glass and epoxy resin. The best method of marking glass is etching while epoxy resin can emit toxic fumes upon laser engraving. These two reasons make fiberglass a bad choice for a laser engraving material
Polypropylene	polypropylene melts and catches on fire easily and then the melted material continues to burn thereby forming pebble-like drips that harden on the surface
Coated Carbon Fiber	Coated carbon fiber emits noxious fumes. Additionally, carbon fiber can be cut albeit with some fraying but this is not the case when it is coated.

(9) The **RAY5** has built in technology and algorithms to keep its users and the surrounding environment safe. This said it is important to understand the **RAY5** is not a toy and should be operated with



care and respect.

## (10) Important information regarding your **RAY5**

**RAY5 20W** use 24V DC power system:

- Never Use a different voltage Power Adapter. The **RAY5** requires DC 24V 5A.
- When using an alternative Power Adapter, the Voltage should always be 24V, the minimum Amperage output should be 5A. Higher amperage output Power Adapter can be used without risk of damage to your **RAY5**.
- On inserting the power barrel into your motherboard, it is possible that a small spark is visible. This is NOT hazardous to your machine and is caused by the 24V power inrush. If you prefer to avoid this, connect the power barrel to your motherboard first, then connect your power adapter to the mains electricity plug.
- Once the **RAY5** detects 24V present you will see the motherboard emit a light red glow on the LED of the Motherboard. This mean the motherboard is powered.
- If when plugging your Power Adapter barrel to your Motherboard and the Power adapter to mains power a

green LED does not turn on, please verify your power adapter is receiving Mains Power.

## B. Product Information

### (1) Specifications

Machine	
Machine Model	<b>RAY5 20W</b>
Working Area	400 x 365 mm (15.7 x 14.4 in)
Power Adapter Input Voltage (AC)	110-240 V, 50-60 Hz
Power Adapter Output Voltage (DC)	24 V
Power Max Consumption	120 W
Packaging Size	621 x 347 x 127mm(24.45 x 13.66 x 5 in)
Packaging Weight	5.51 Kg
Machine Size Assembled	61 x 67 x 20 cm (24.0 x 26.4 x 7.9 in)
Operating Temperature	-20 – 50°C
Laser Module (20W)	
Laser Module Model	RAY5 20W
Laser Technology	Four Diode Laser with FAC
Wavelength	450 - 460 nm
Max Power Input	24V 3.2A
Optical Power Output	18 - 21 W
Focus Type	Fixed Focus – 50mm Focal length
Dot Size at Optimal Focus	0.08 x 0.10 mm
Laser Class	FDA Class IV, or Class 4 IEC standard
Applicable Material	Engraving: Plywood, Basswood, Hardwood, Pinewood, Acrylic, Kraft paper, Stainless steel, Aluminum alloy, Ceramics, etc. Cutting: Basswood, Acrylic, Bamboo, Kraft paper, etc.
Software	
Software	LaserGRBL (free), LightBurn (paid)
Operating System	LaserGRBL: Windows Lightburn: Windows, MacOS, Linux
Input Image Format	JPG, PNG, BMP, GIF, SVG, AI, etc.
Connection type	USB cable, Micro SD Card, Wi-Fi

## (2) Components Introduction

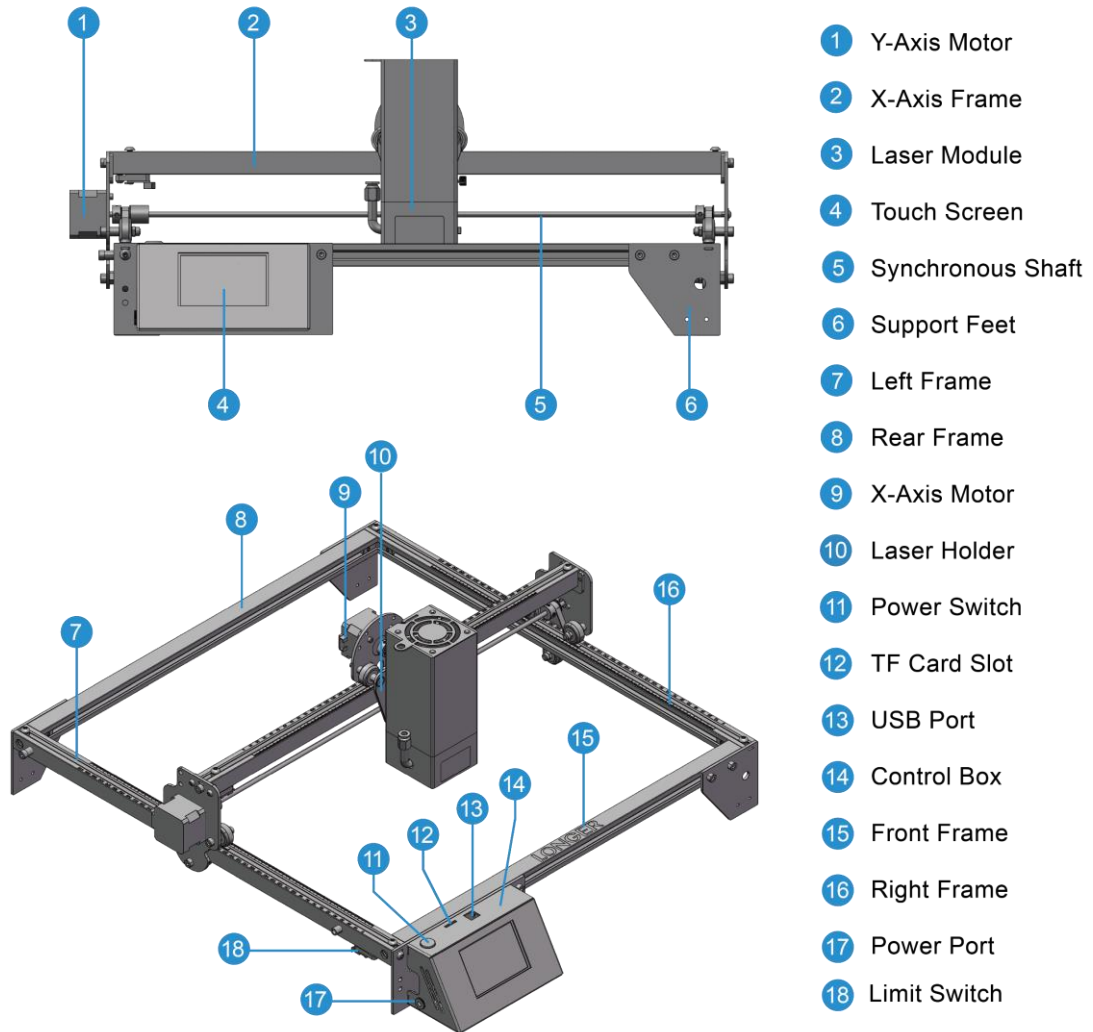

- 1 Y-Axis Motor
- 2 X-Axis Frame
- 3 Laser Module
- 4 Touch Screen
- 5 Synchronous Shaft
- 6 Support Feet
- 7 Left Frame
- 8 Rear Frame
- 9 X-Axis Motor
- 10 Laser Holder
- 11 Power Switch
- 12 TF Card Slot
- 13 USB Port
- 14 Control Box
- 15 Front Frame
- 16 Right Frame
- 17 Power Port
- 18 Limit Switch

### (3) Packing List

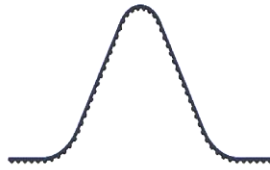
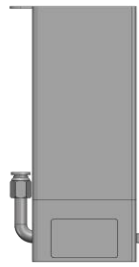
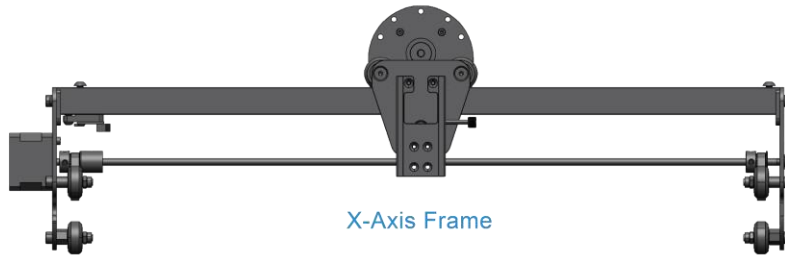

#### **(4) Machine assembly**

The machine step-by-step assembly process is described in the document “RAY5 20W Quick Start Guide”. Please follow the guide to assemble machine.

- During the machine assembly, if there is any unclear place, please refer to the video “RAY5 20W Quick Start Guide”.
- Each unit of the engraving machine has been inspected and tested. Therefore, in some cases, very small traces may be left on the profile and the metal shell. These will not affect the quality. It is normal that it does not affect normal engraving. Thank you very much for your understanding.
- Be cautious during assembly as some parts may have sharp edges.
- If you have any questions after receiving the product, please contact our customer service first.

- 1 Place the profiles on a flat table in order, and place four corner grooves into the profiles referring to diagram. ▼

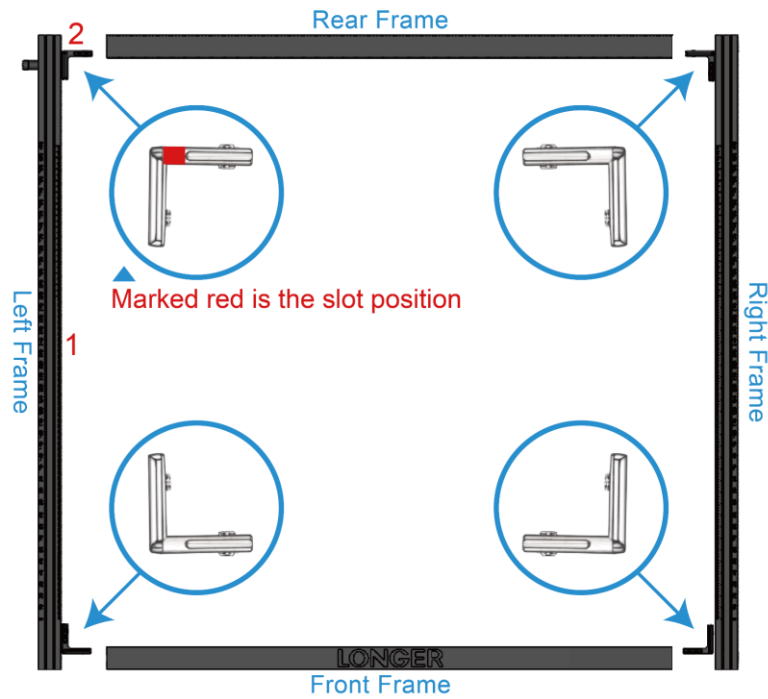

- ▼ Tighten the M5\*25 screw with M5 washer into frames.  
Tighten the M5 screws on the corner grooves.

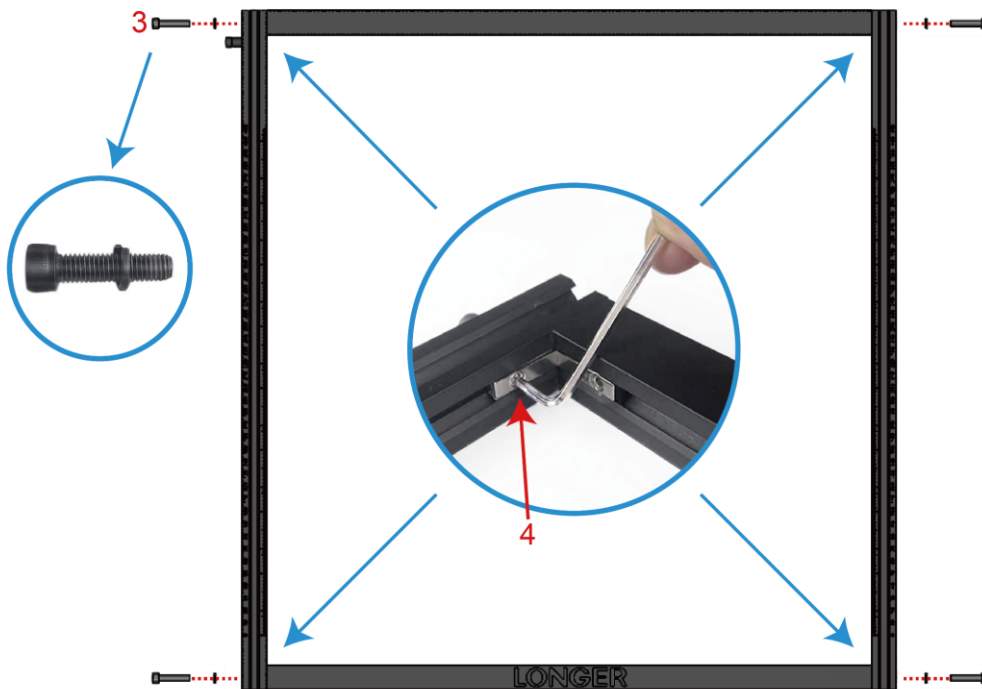

**2** Preparation:  
X-Axis Frame, and the frame to complete the assembly.

Install the X-Axis Frame in the V-groove of the left and right Frames along the direction of the arrow.

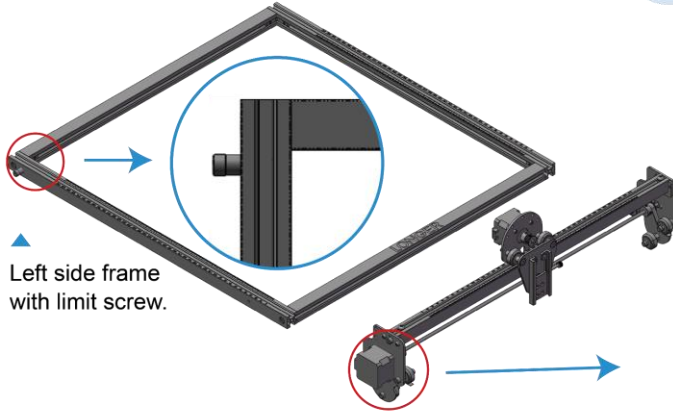

Left side frame with limit screw.

Pay attention to adjusting the eccentric nut to prevent the roller from being damaged by the groove. ▼

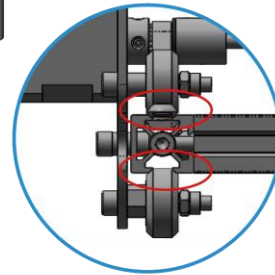

**3** Preparation:  
Support feet x3, engraving machine control box, M5\*16 hexagon socket cup head screw x8, M5\*8 hexagon socket round head screw x1, nylon isolation column (7\*5\*6) x1.

According to the figure, install the supporting foot, the control box of the engraving machine, and the left profile limit screw in the corresponding position.

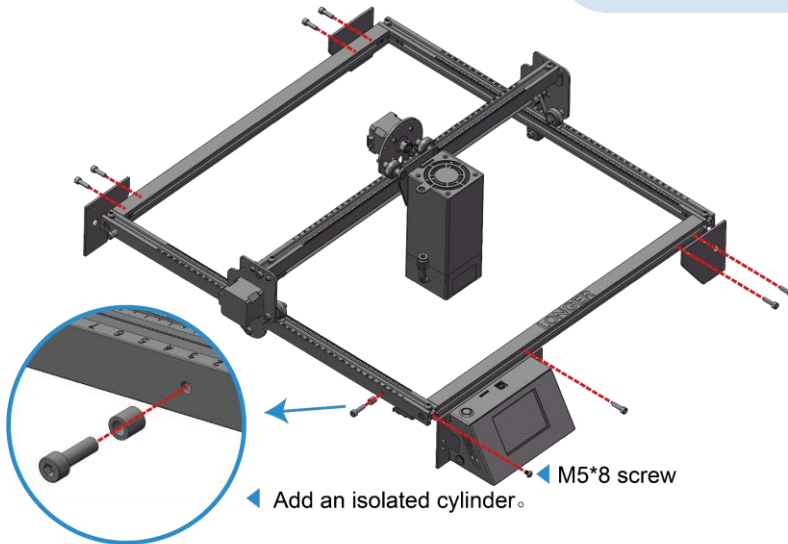
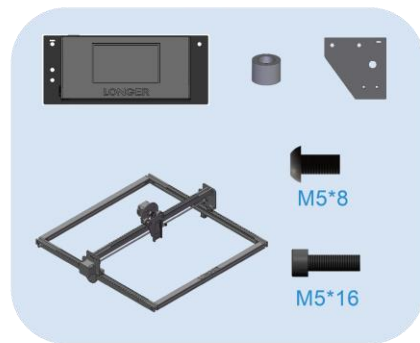

◀ Add an isolated cylinder. ▶ M5\*8 screw



**4** Preparation:  
Limit switch x2, Timing belt x2, M5 T-shaped nut x4, M5\*6 hexagon socket head screw x4.

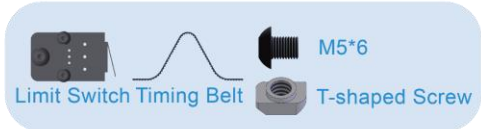

1. Place a timing belt along the red arrow with the tooth face down.
2. Put the T-shaped nut on one end of the belt, use an L-shaped screwdriver to rotate the T-shaped nut, then screw in the M5\*6 screw to fix one end of belt.
3. Tighten the belt by hand, then fix another end of belt in the manner of previous step.
4. Fix another belt on left frame in the same way.

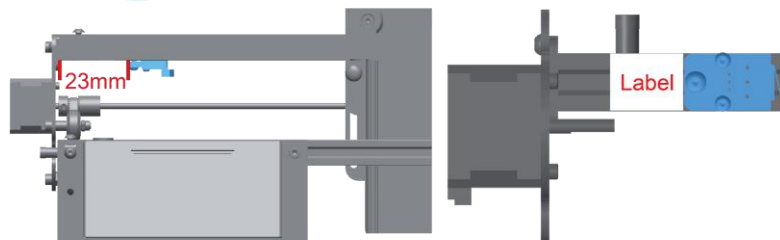
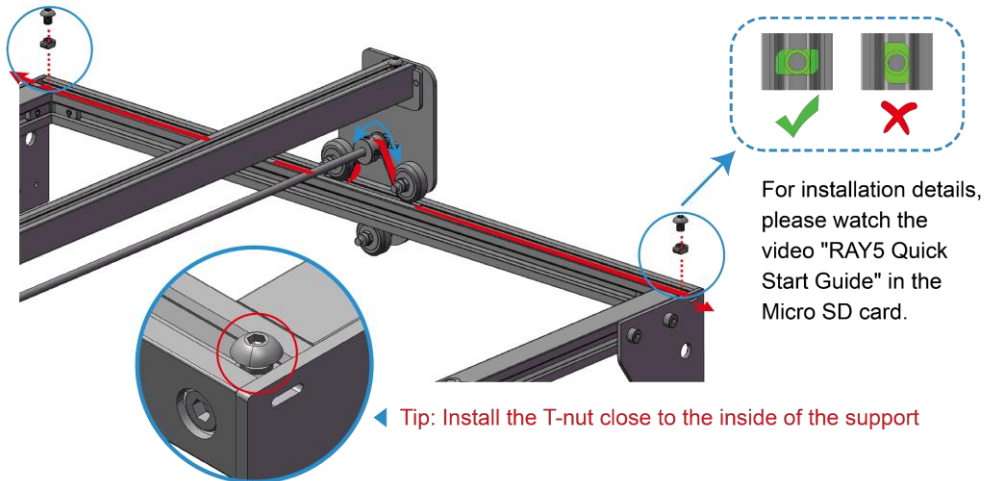

5. Turn the RAY5 engraver over, attach the limit switch to the edge of the label, and fasten it with a hex key allen wrench, then limit switch is about 23mm from the left sheet metal.

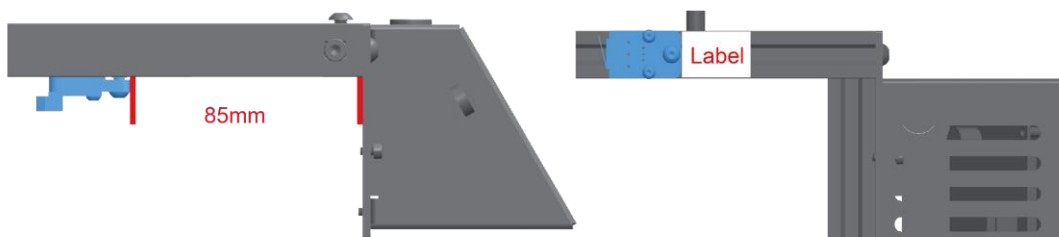

6. Attach the limit switch to the edge of the label, and fasten it with a hex key allen wrench, then limit switch is about 85mm from the right sheet metal.

**Note:** Please install the limit switch attached with label, otherwise it will affect the engraving size or cause the laser head module to collide with the profile when homing.

**5** Preparation:  
Laser module, M3\*20 Handle screw



First install the laser module on the X-axis frame, then tighten the M3\*20 handle screw to fix the laser module

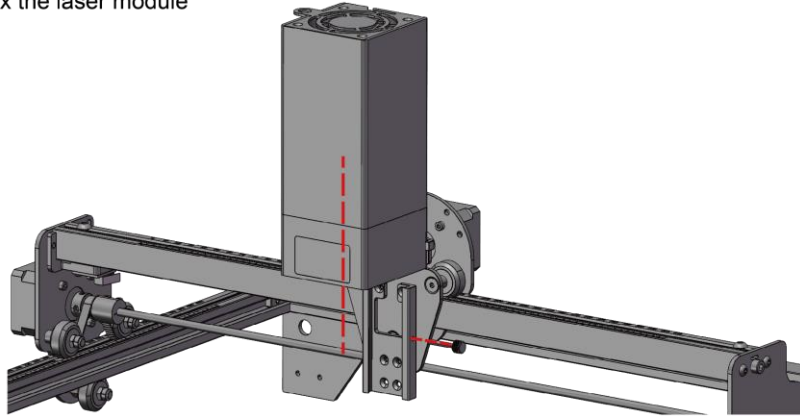

**6** Connect the cable to the motor, limit switch and the laser head as shown in the figure.

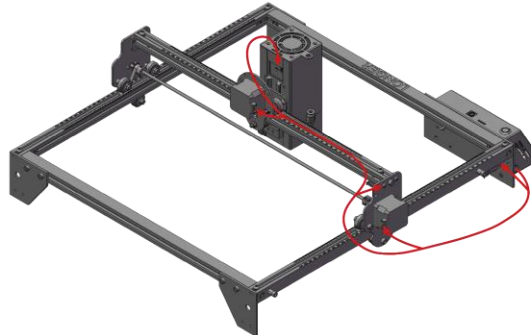

Note: Fix the cable to the sheet metal with cable ties where there is tape, and then move the laser head to the upper right corner to confirm that the cable has sufficient length

**7** Adjust laser focus:  
Pull out the focusing block, loosen the M3\*20 handle screw, move the laser module down, tighten the M3\*20 handle screw when the bottom of the focusing block touches the plywood, and close the focusing block

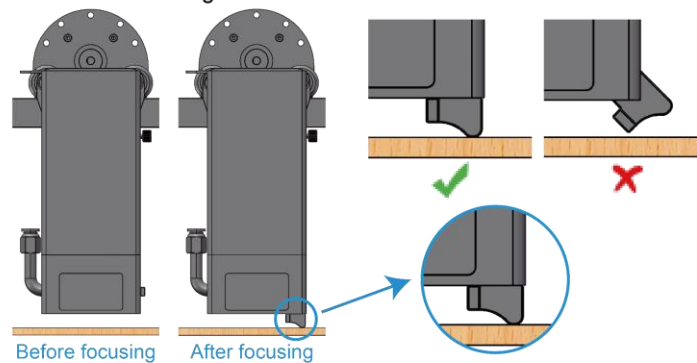

Please reference more details on digital manual in TF card about the operation of Laser Engraver and installation of LaserGRBL or LightBurn.

## C. Machine Operation

### (1) Focusing the Laser Module

- a) Place the machine on a flat table and make sure that the machine is stable and will not shake.
- b) Place the wood board to be engraved or cut under the laser.
- c) Pull out the focusing block, loosen the M3\*20 handle screw, move the laser module down, tighten the M3\*20 handle screw when the bottom of the focusing block touches the plywood, and close the focusing block.

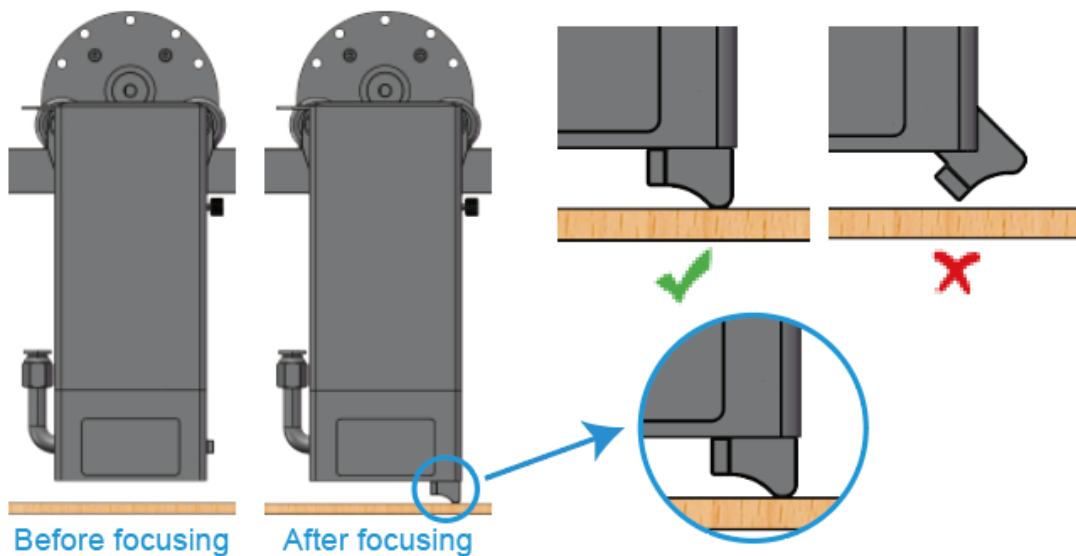

## (2) Power On

- a) Find the adapter and power cable and connect them. Please make sure the output of **RAY5 20W** adapter is DC 24V 5A.
- b) Connect the power cord to the power supply and connect the other end of the adapter to the power port of the motherboard.
- c) Connect the computer and the engraving machine through a USB computer (or insert a Micro SD card).
- d) Turn ON your **RAY5 20W** by press the power switch (To Turn OFF your **RAY5 20W** by press the power switch once again.)

## (3) Touch Screen Operation

**RAY5 20W** has a full-color 3.5-inch touch screen with a user-friendly user interface. Engraving and cutting work can be operated with touch screen and SD card.

- a) Home page

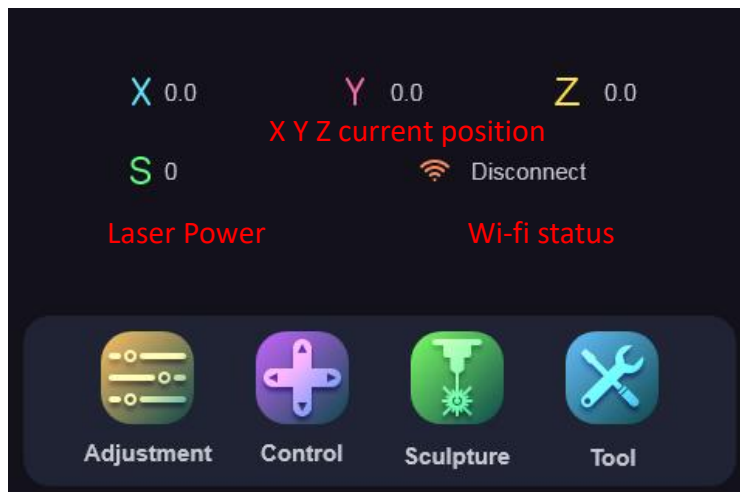

b) Adjustment page

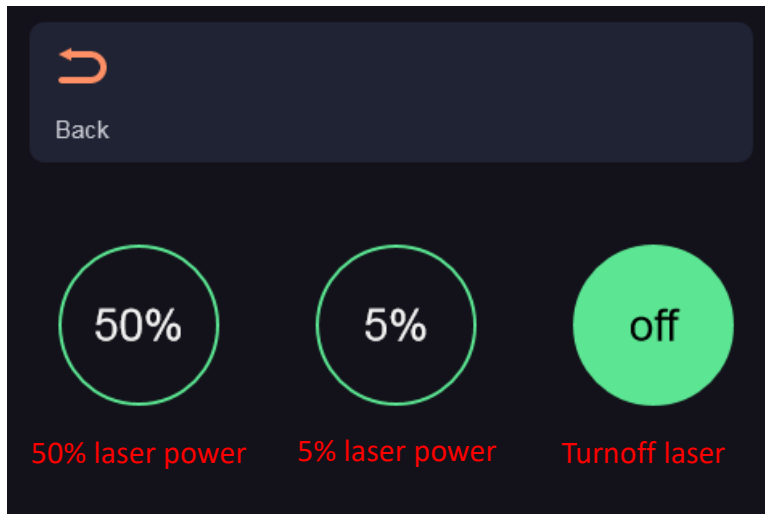

c) Control page

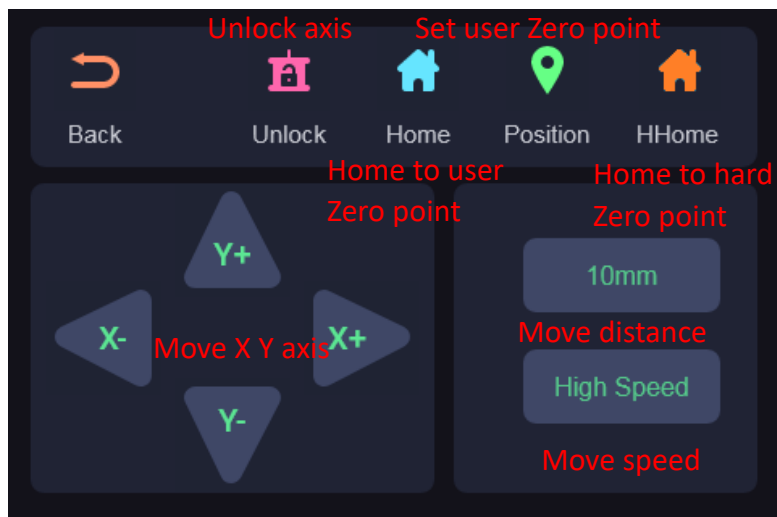

User zero point refers to the position where the user manually confirms that the position of the laser head to the zero. While hard Zero point is the point determined by X and Y limit switch.

d) Engraving page

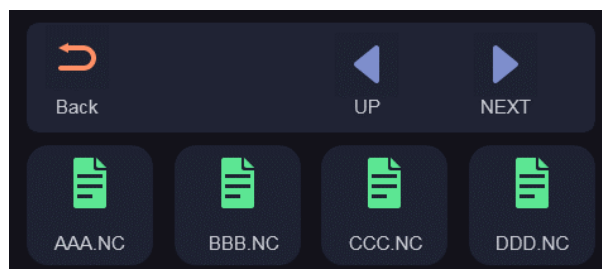

e) Ready to engraving/cutting page



f) Engraving/cutting working page

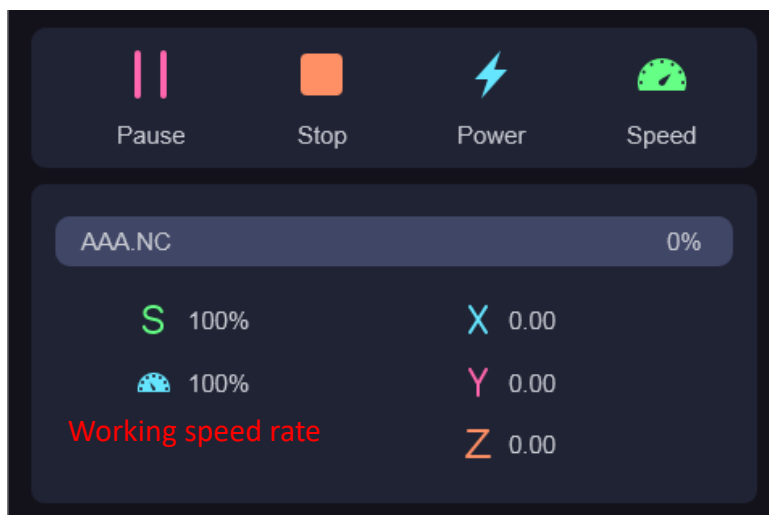

g) Set speed page

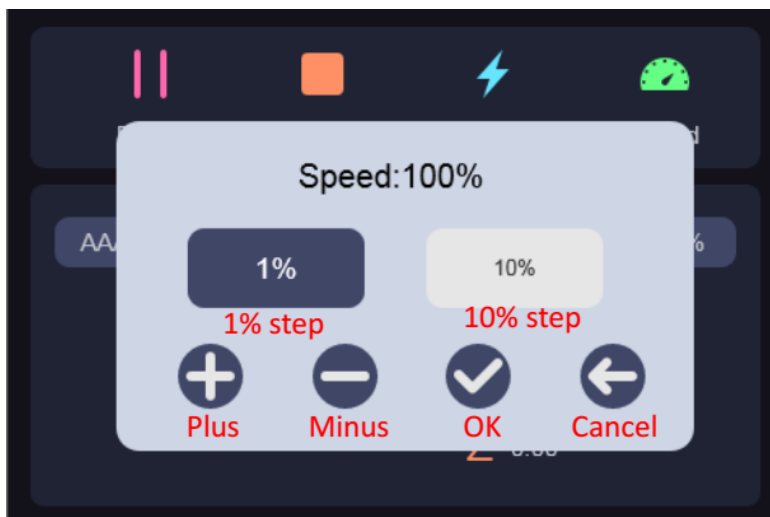

#### (4) Wi-Fi Control operation

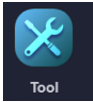
- a) Tap tool icon  on the home page
- b) Tap Wi-Fi icon on the top right corner of tool page



- c) Select Wi-Fi name on Wi-Fi list page

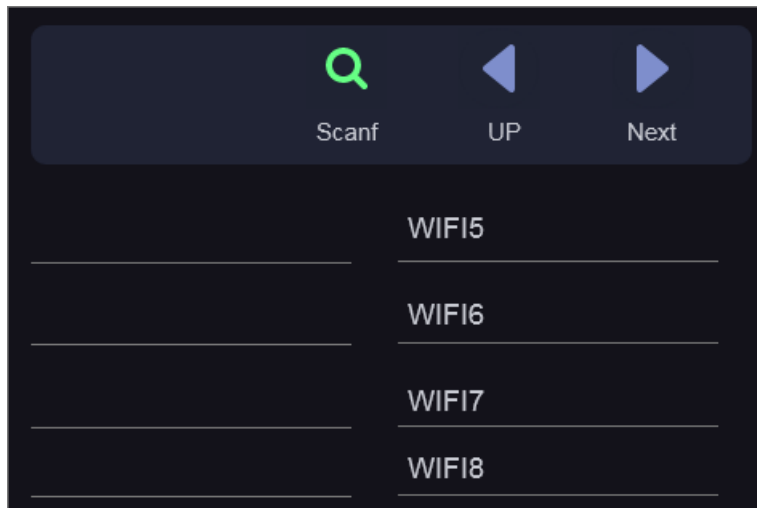

- d) Enter password and waiting for connect to the Wi-Fi you select.
- e) Check the current connected Wi-Fi status.(pay attention to IP address)

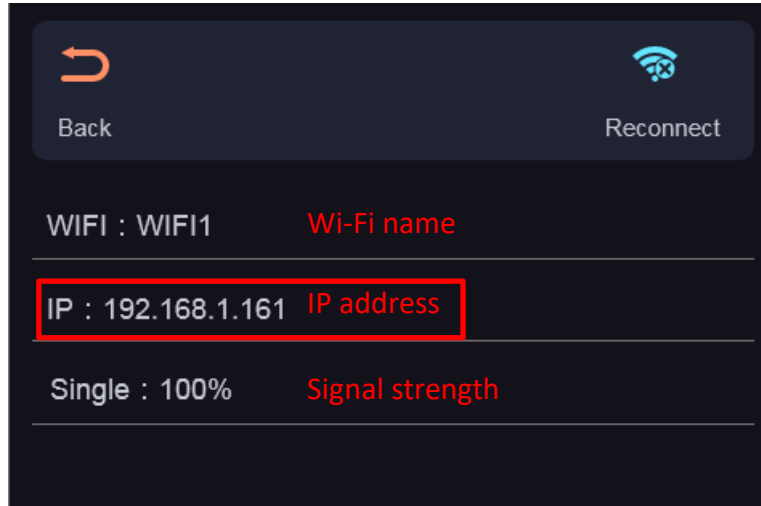

f) Enter the IP address in the browser of mobile phone or computer, then the control interface will pop up.



g) Click SD File tag, it will change to SD file page.



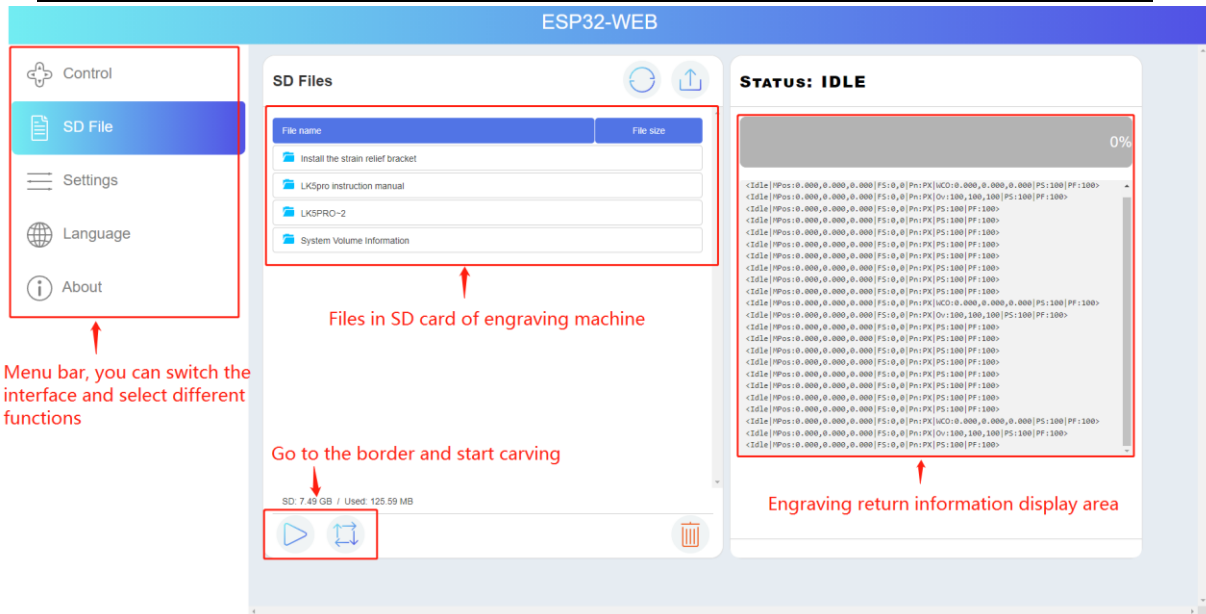

h) Upload “.gcode/.nc” files generated by “LaserGRBL” or “LightBurn” software(The two software are introduced in the following sections). Then go and play!

## (5) LaserGRBL Software Operation

LaserGRBL is an easy-to-use and fully free software for laser engraver only running on Windows.

### Setup

- a) Find LaserGRBL software in attached SD card(path: /software),  
Or download from the link: <https://lasergrbl.com/download/>
- b) After installing laserGRBL, power up the **RAY5**, press the power switch button, and connect the laser engraver and computer via USB cable.
- c) Open LaserGRBL, select correct port(depend on your PC), baud rate: 115200. Then click connect button.(If you cannot find correct port, please install CH340 driver manually by click Menu >> Tools >> Install CH340 Driver in LaserGRBL)

# Usage

## a) Main Interface

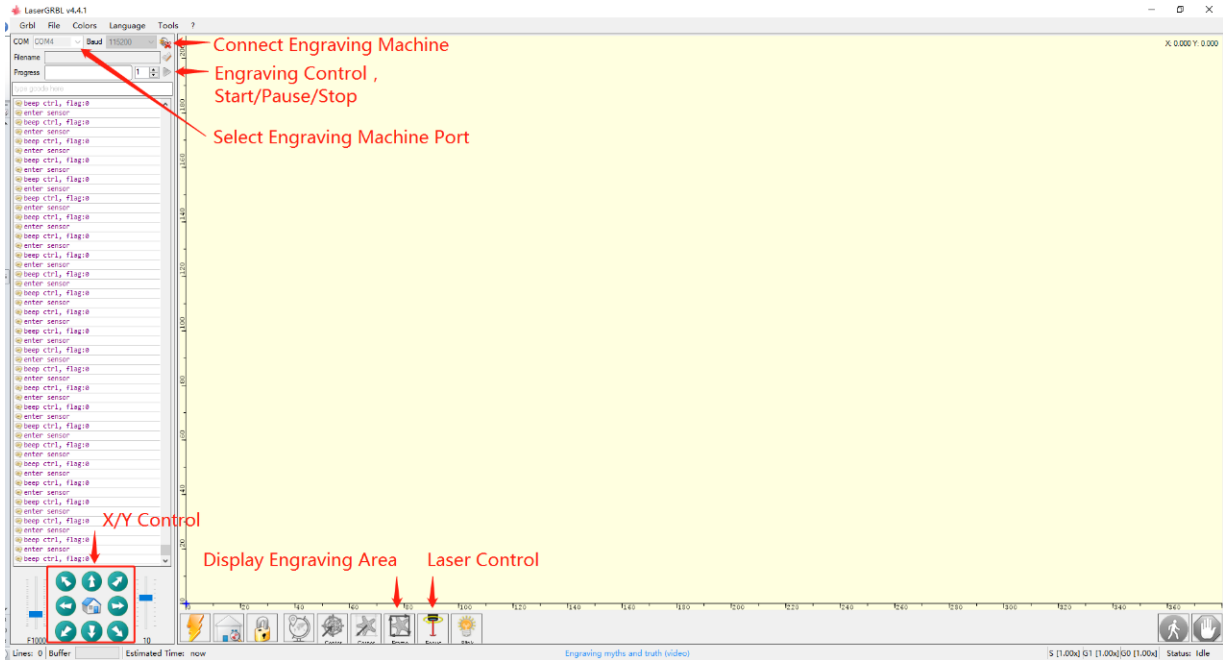

## b) Open file and set parameters

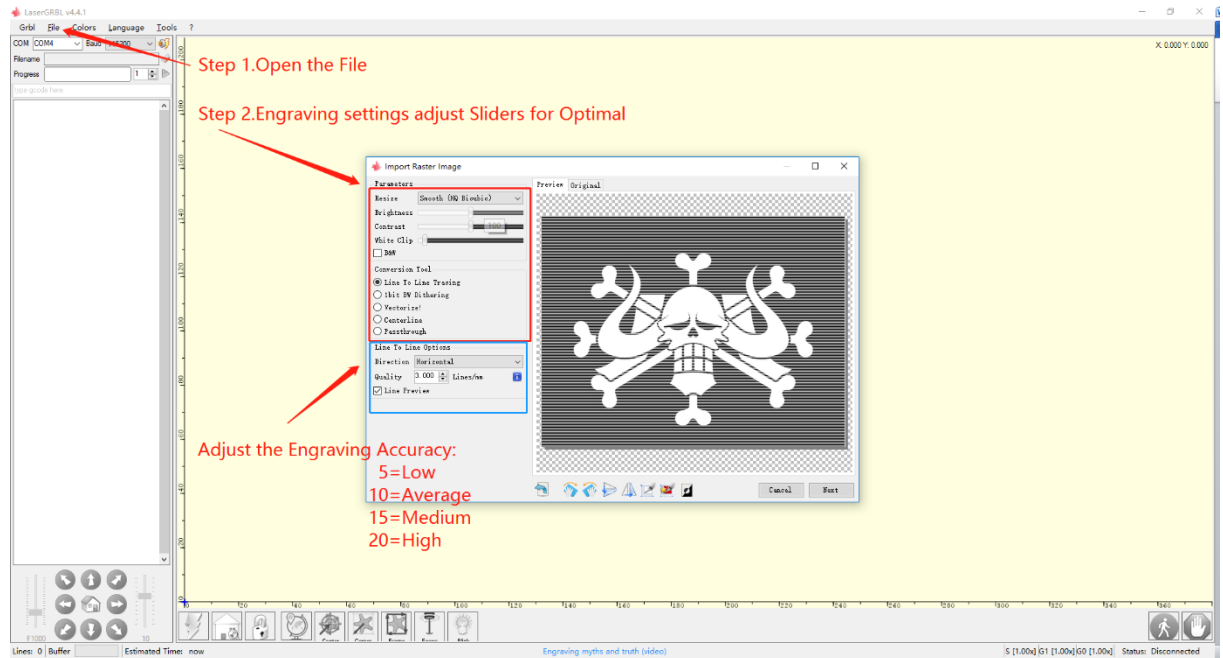

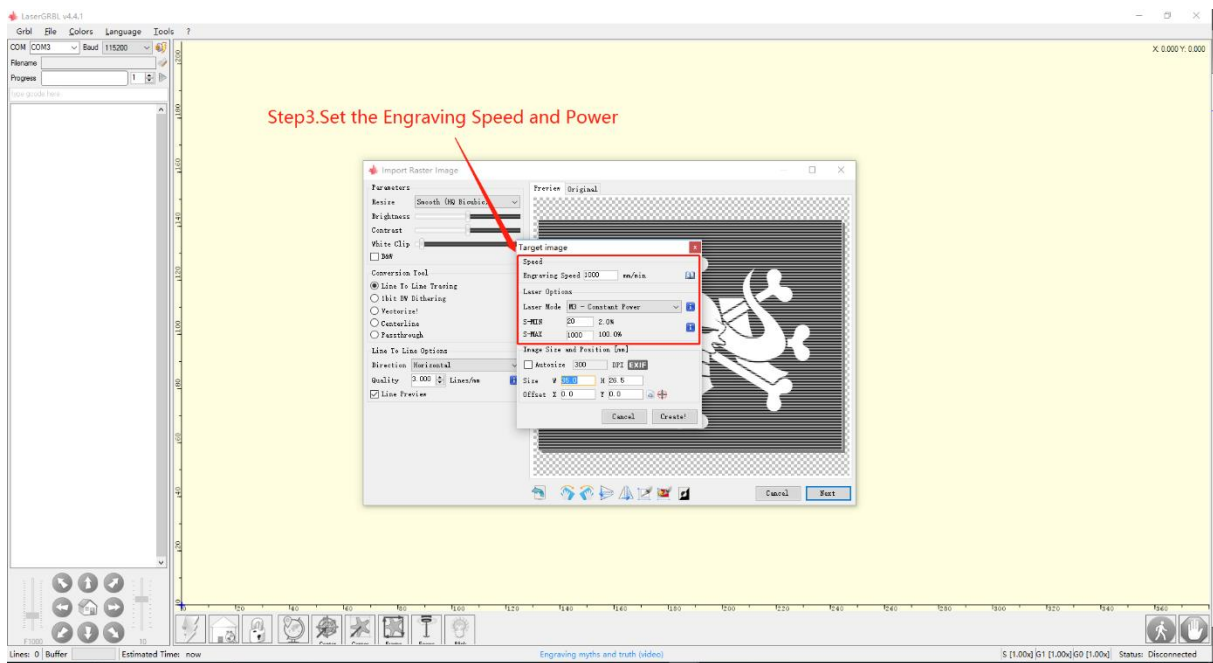

c) Start to engrave

- i. Place a board under the laser, then calibrate the laser.
- ii. Move the laser head to the place you want.
- iii. Click “Frame” button to check the work frame.

- iv. Click  button to start engraving.

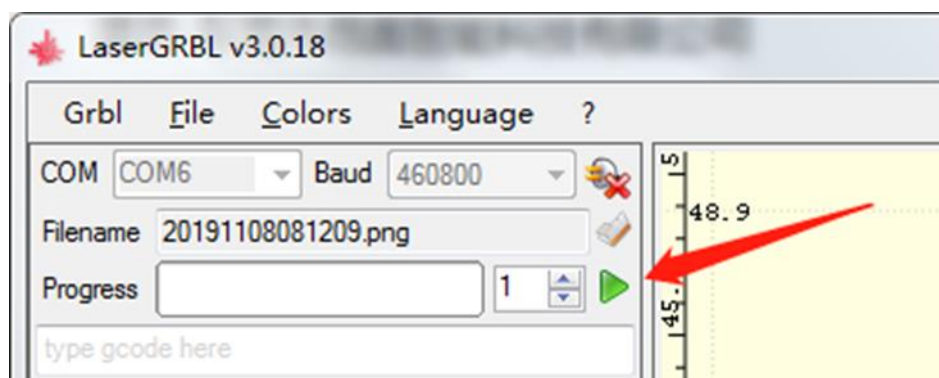

- v. Or you can save gcode file to SD card by click “File” >> “Quick Save” for offline working.

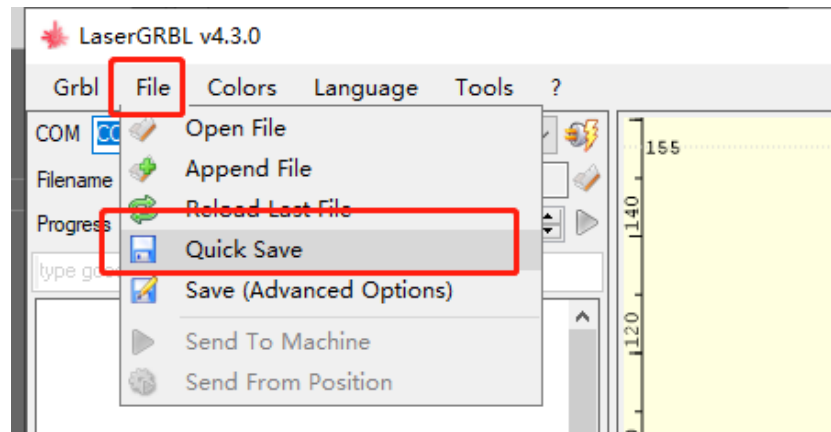

More help information about LaserGRBL, please refer to the link:

<https://lasergrbl.com/usage/>

## (6) LightBurn Software Operation

LightBurn is professional software for engraver, a charging software running on Windows, MacOS, and Linux. It provides a trial period. You could pay for it afterward if you like it.

### Setup

- a) Find Lightburn software in SD card(path: /software) came with the package. Or just download from the link:  
<https://lightburnsoftware.com/download/>
- b) After installing Lightburn, power up the **RAY5**, press the Power Switch button, and connect the laser engraver and computer via USB cable.
- c) For the first time launching LightBurn, it will prompt a “New Device Wizard” for help you setup machine.
- d) Select GRBL form the list, then click “Next” button

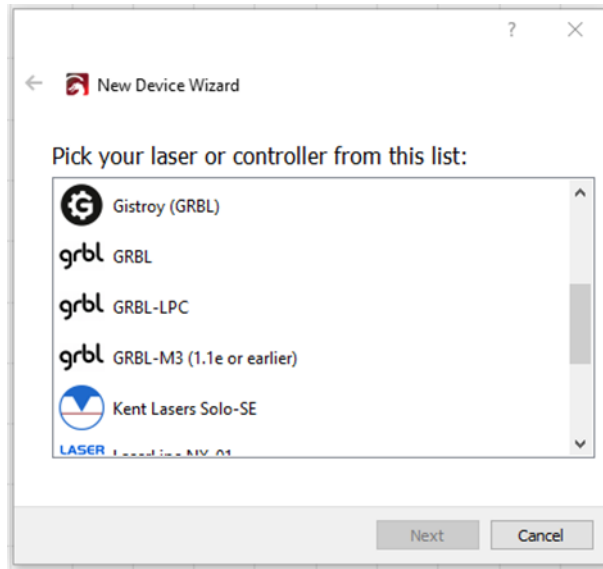

e) Select Serial/USB and press “Next” button.

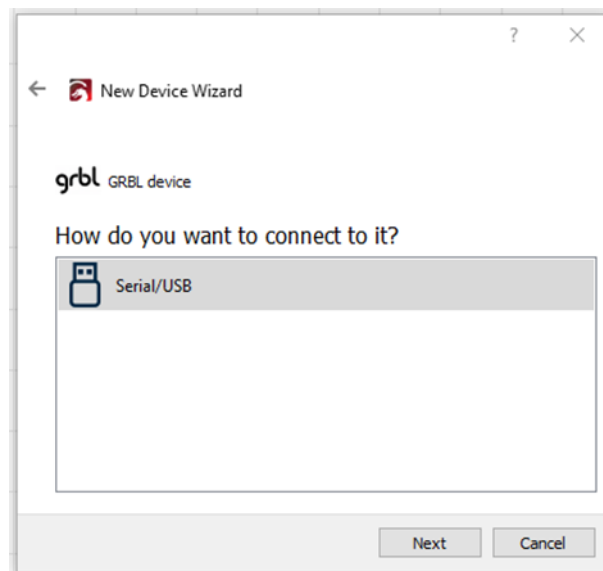

f) Fill your Device Name, X, Y axis, then click “Enter” button

Name: **RAY5 20W**

**X = 400**

**Y = 365**

**The max engrave size of RAY5 20W is different from RAY5 5W or 10W, so if you own RAY 5W or 10W before, please add the new engraver manually before using the RAY5 20W.**

- g) Select “Front Left” as your Origin X,Y and activate “Auto ‘Home’”, then click “Next” button.

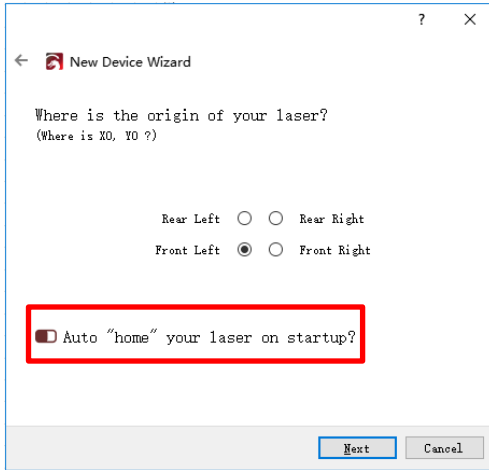

The automatic home function is turned on by default, if you do not want the engraver to automatically home when power on, it is recommended to turn off this function.

- h) Select **RAY5** and press Make Default. Your **RAY5** is ready to be used in LightBurn software.

## Usage

- a) Main interface

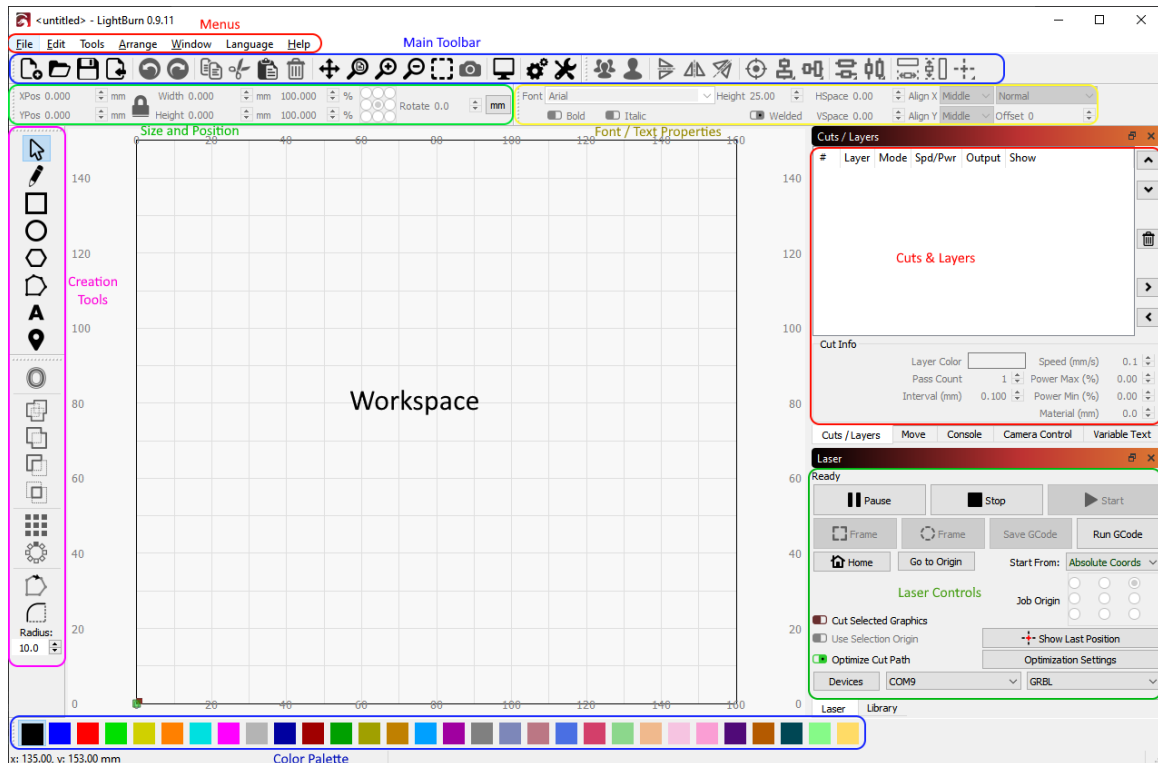

- b) Select correct port (depends on your PC), then the **RAY5** is connected to the computer.

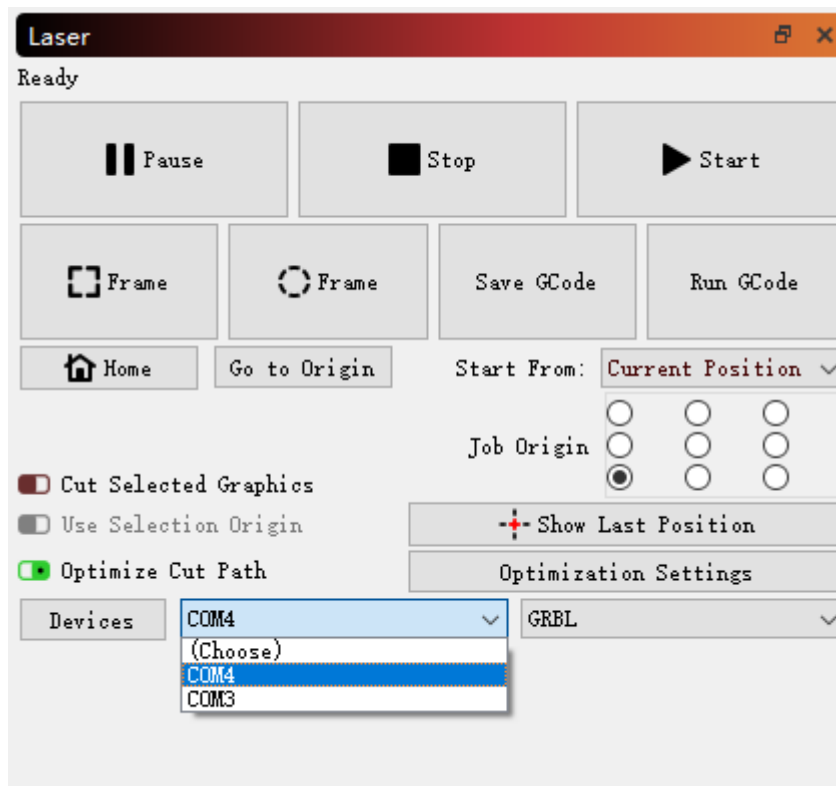

- c) Click Menu “File” >> “Import image from disk.” Or just use draw tool on left column to design your own pattern.

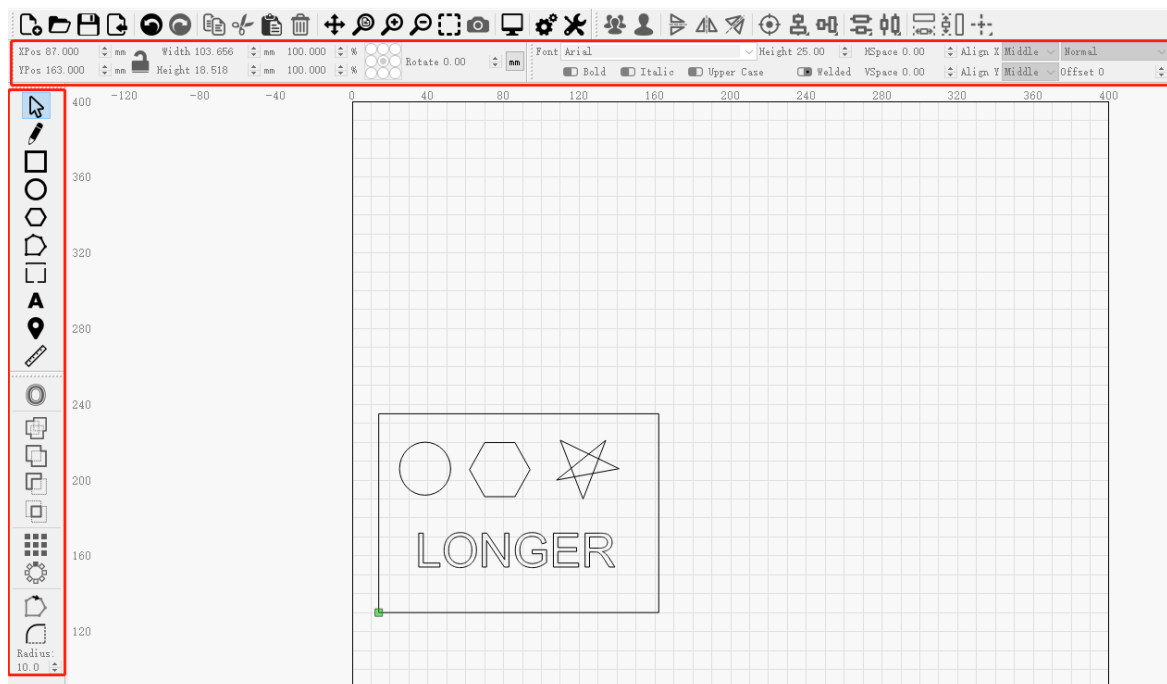



- d) Set the name, speed, maximum power, mode, and other parameters in the cutting/layer; (engraving function and cutting function are only different in speed, power. Normally, the cutting speed parameter is slower).

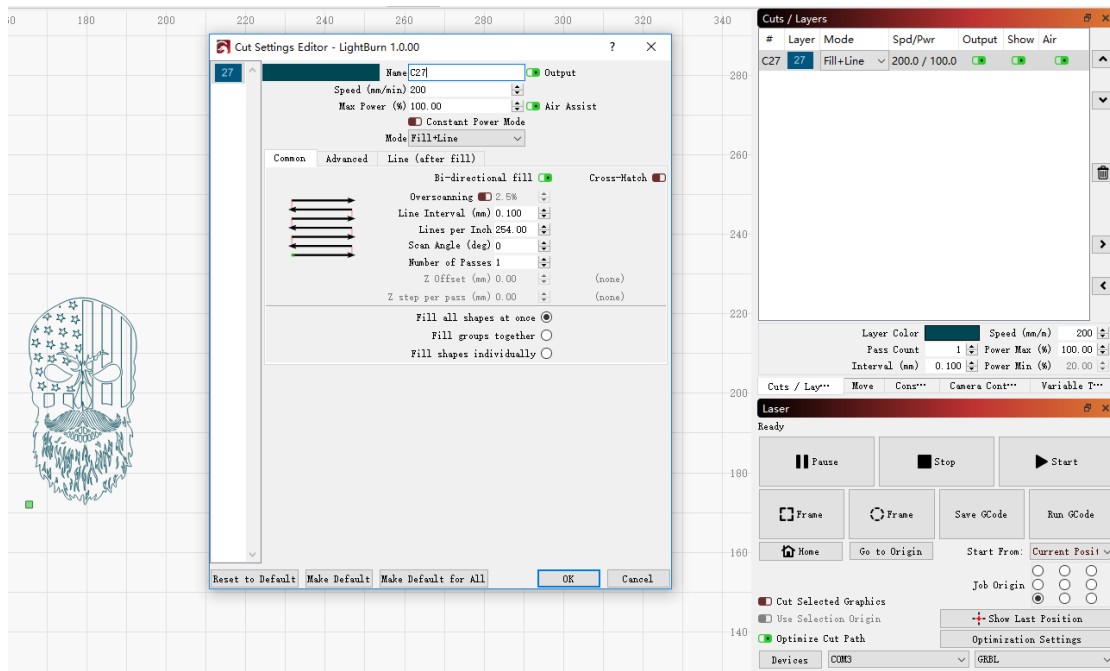

- e) After placing the board under the laser, click **Frame** to check the laser path whether is completely inside of the board.
- f) Click “Start” to start to work.
- g) Or you can save gcode file to SD card by click “Save GCode” button in Laser panel for offline working

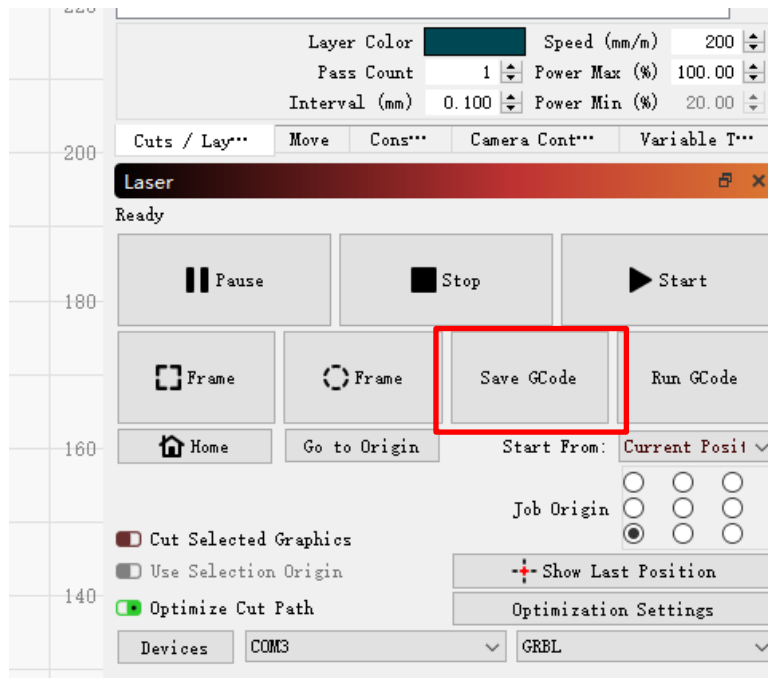

More help information about LightBurn, please refer to the link:

<https://lightburnsoftware.com/pages/tutorials>

## (7) Firmware Upgrading

The Firmware of **RAY5** is continuously updated for fixing bugs and add new features. The firmware upgrade operations are different for different systems. The detailed tutorial about firmware upgrading is contained in the firmware package. Please download **RAY5** firmware package from the LONGER official website: [RAY5 firmware download](#)

Install the MKSLaserTool\_setup V1.1.2.exe file, click [MKS ESP32 Download Tool](#), select the [right port](#) and .bin update firmware, and click [Start](#), it will prompt firmware successfully flashed after the update is completed.

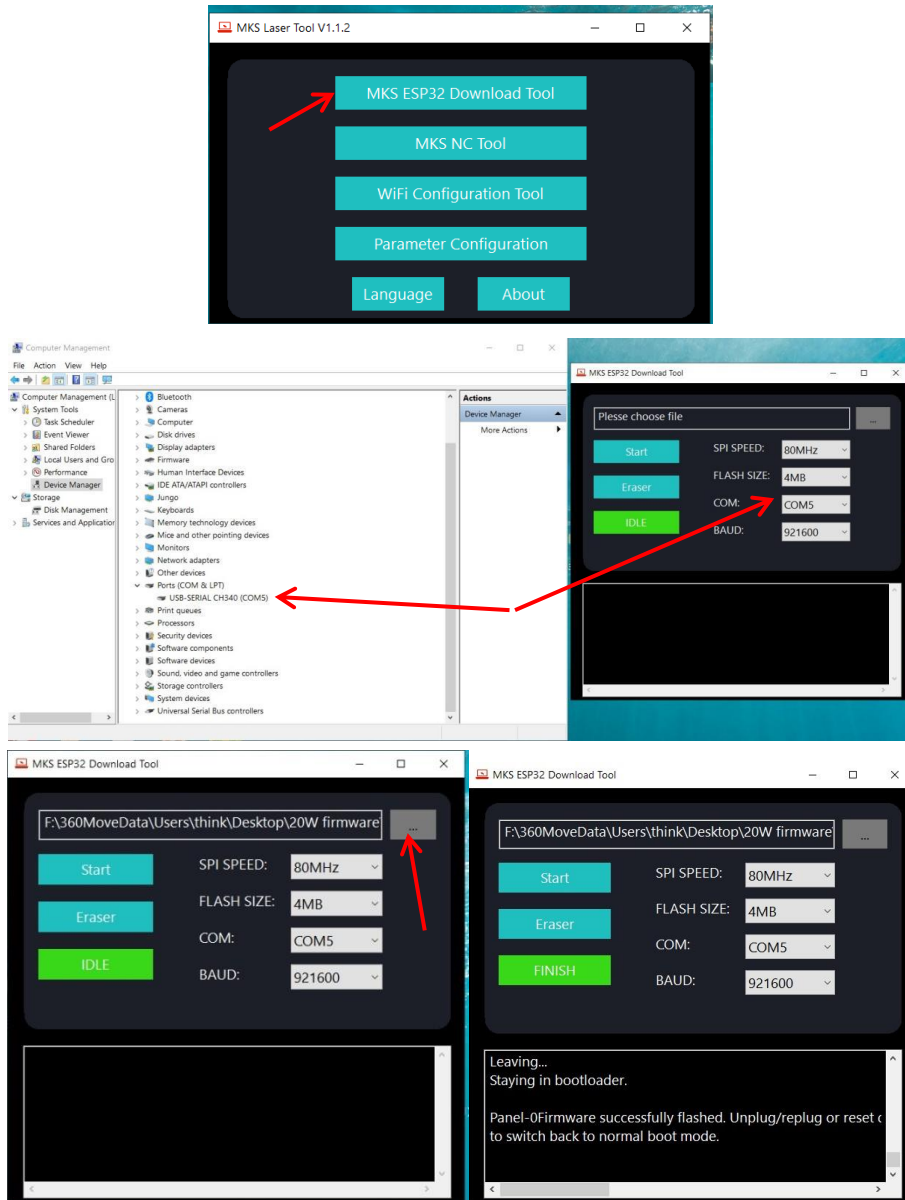

Copy the [dlc\\_cfg.txt](#) file from the configuration folder to the root directory of the SD card, insert the SD card into the main board of the engraver, restart the engraver, and the configuration file update will be completed automatically.

## (8) APP Operation

RAY5 can be controlled or engraved through MKSLaser APP when the engraver and APP are connected to the same WIFI. Please refer to

page 20 about the operation of connecting the engraver to WIFI.

a) How to download the MKSLaser APP

Please search for "MKSLaser" in Google play or app store or visit the address below to download Android system

<https://play.google.com/store/apps/details?id=makerbase.com.mkslaser>

Please search for "MKSLaser" in the app store or visit the address below to download

<https://apps.apple.com/us/app/mkslaser/id1542756280?uo=4&at=1116hc&app=itunes&ct=fnd> for Apple system

b) Home page about the APP

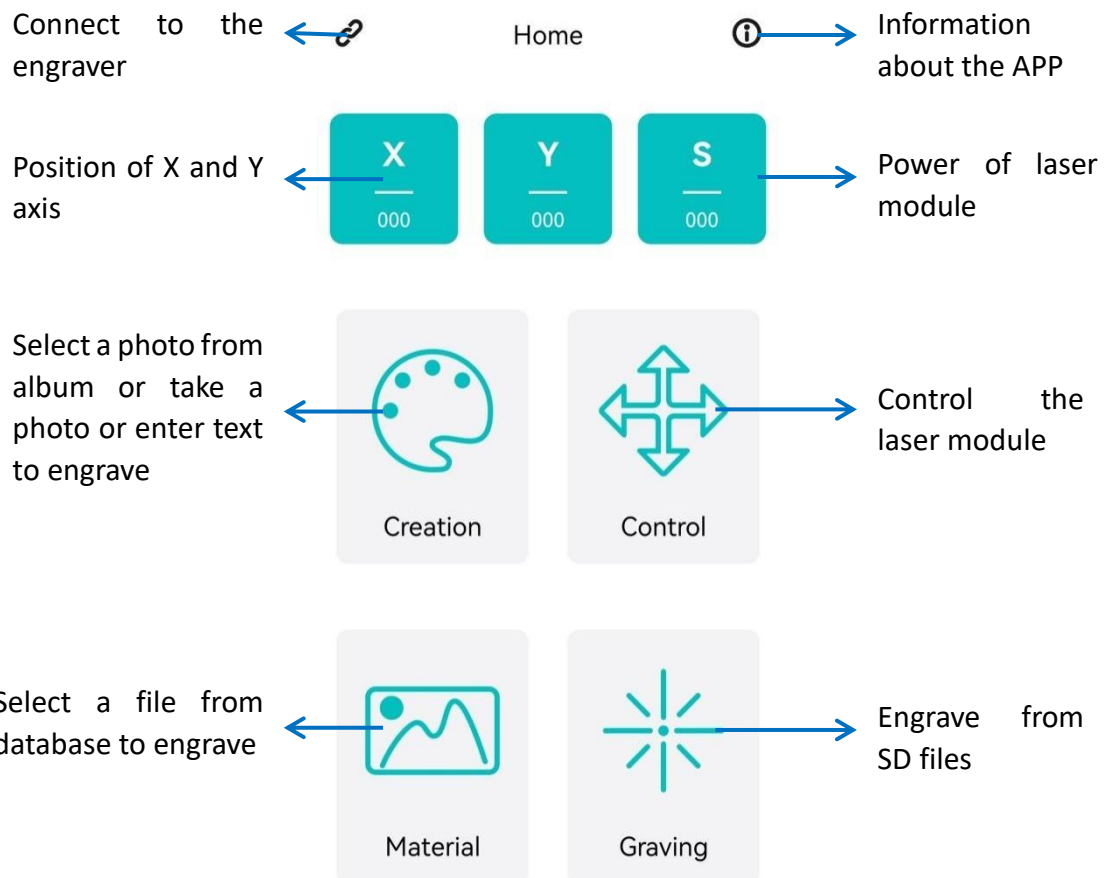

### c) Connect APP to WIFI

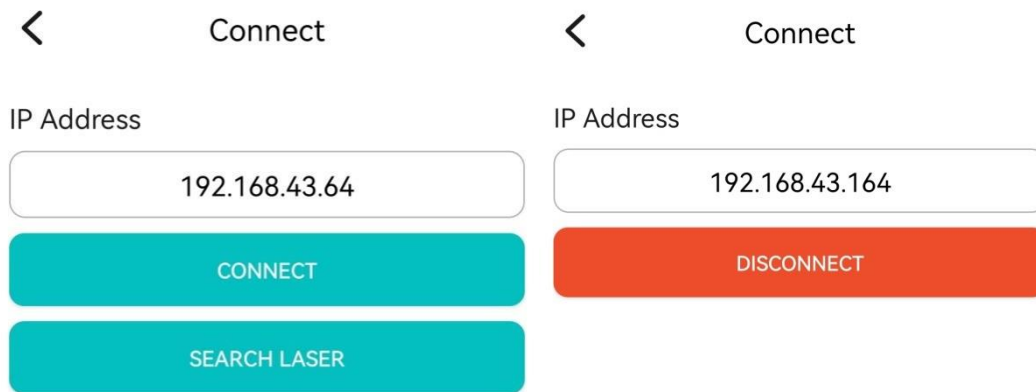

When the RAY5 engraver is connected to wifi, we will get an IP address, click the connect button in the upper left corner of the APP, enter the IP address, and click CONNECT.

### d) Enter text or take a photo to engrave

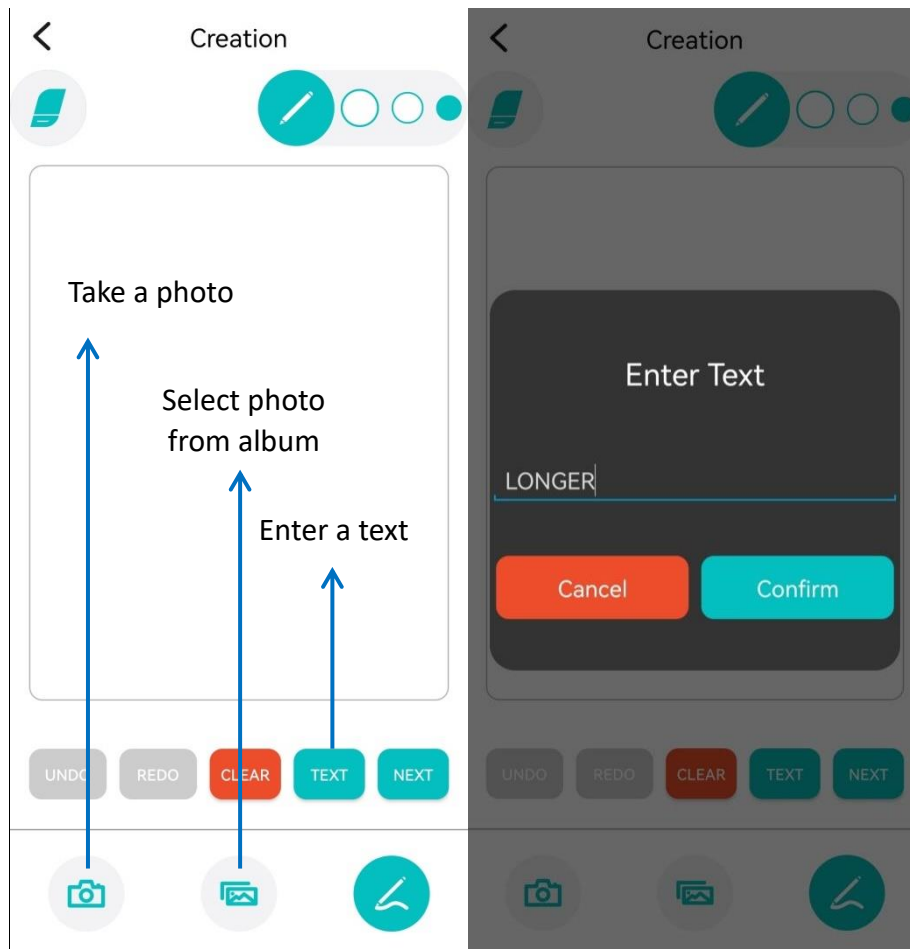

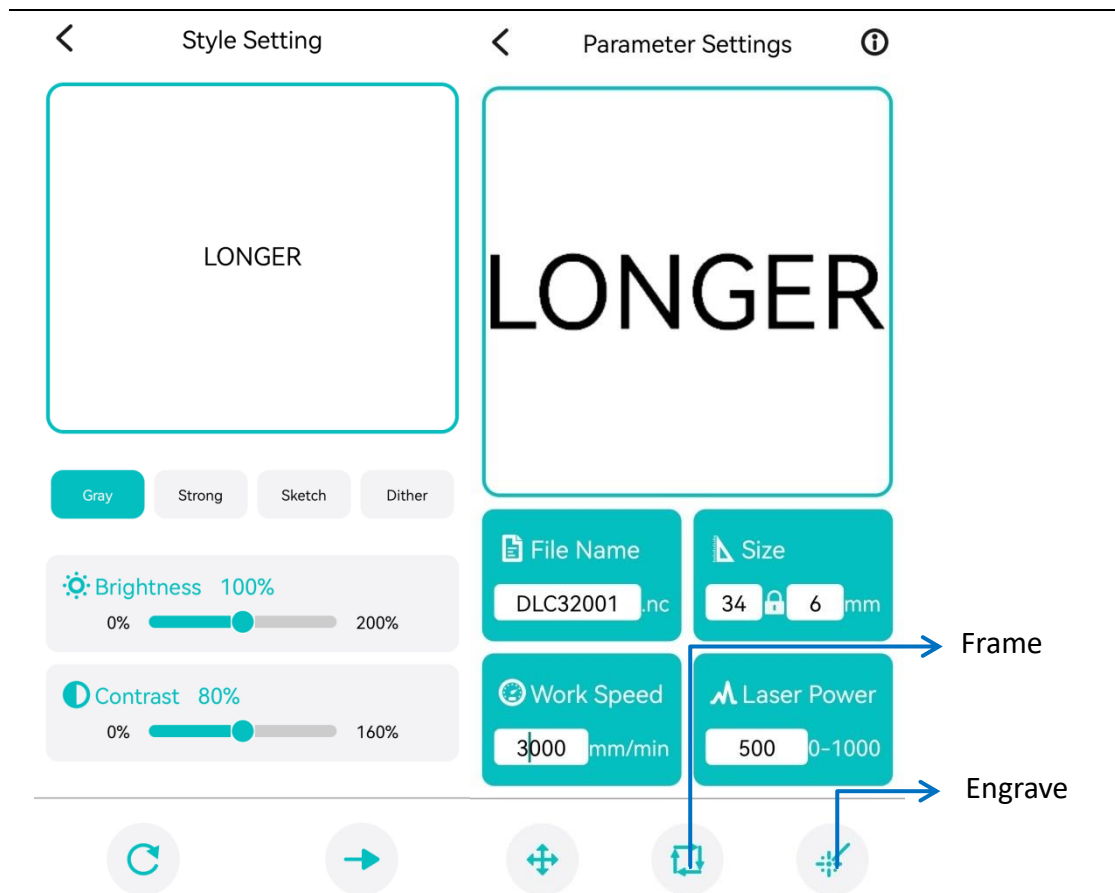

Click [Creation](#), choose free drawing or input text, click [Next](#), adjust the brightness and contrast, click [Next](#), set the size, engraving speed, laser power (such as input 1000 for 100% power, and so on), click [Frame](#) to confirm the engraving range, click [Engrave](#) for working.

For picture, it can click [Creation](#), choose camera or album to take or select a photo, click [Next](#), adjust the brightness and contrast, click [Next](#), set the size, engraving speed, laser power (such as input 1000 for 100% power, and so on), click [Frame](#) to confirm the engraving range, click [Engrave](#) for working. After engraving, click [Confirm](#) to enter the [Graving View](#) to check the engraving progress, adjust parameters, pause or cancel the engraving process.

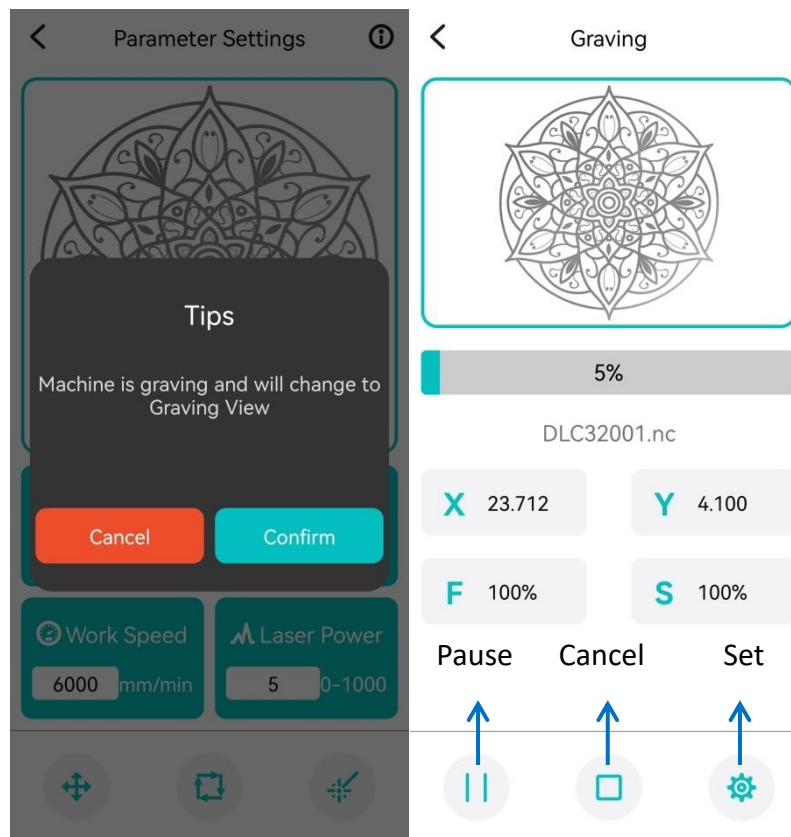
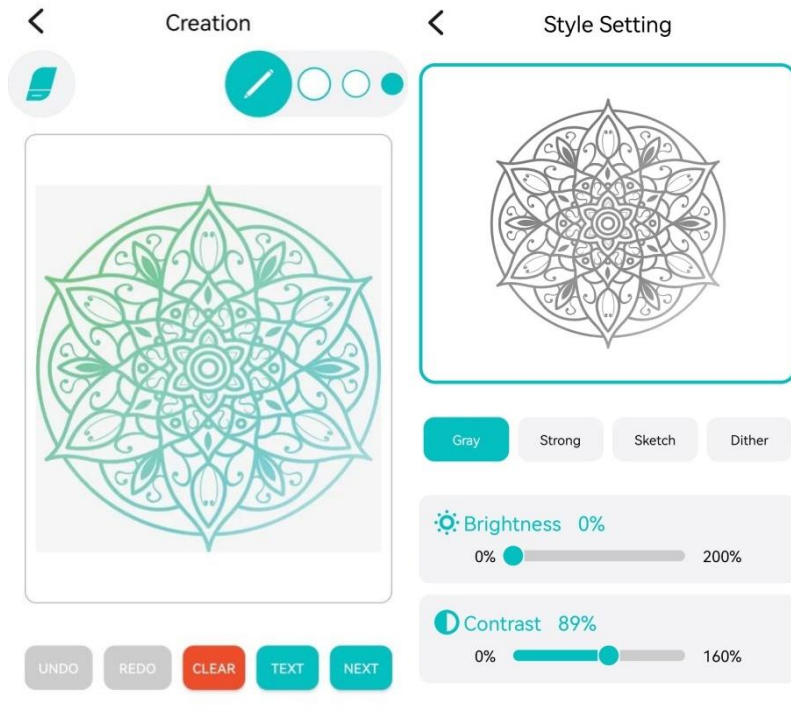

## e) Control the engraver from APP

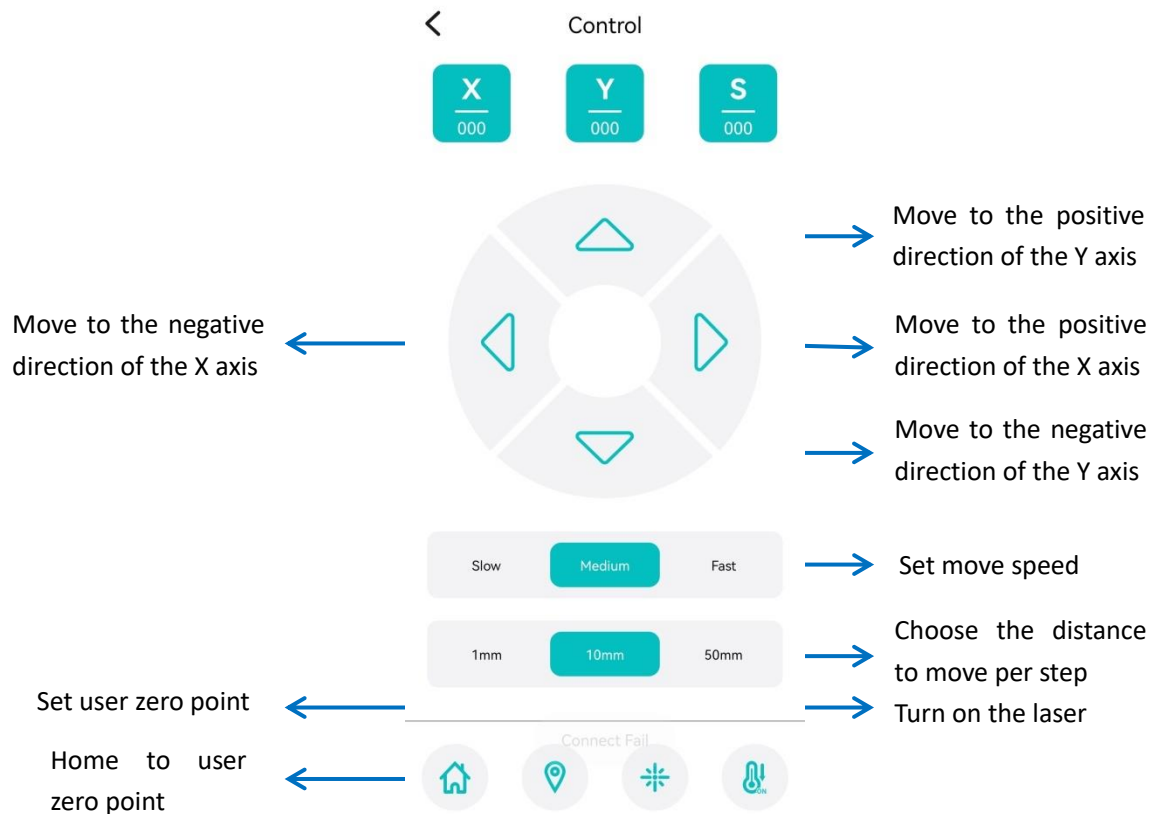

## e) Engrave from SD files

Click **Graving** on the home UI, the APP will read the engraving file in the SD card, select the engraving file, click **Frame** to determine the engraving range, and click **Confirm** to start engraving.

**In the Graving View** UI, it can check the engraving progress, adjust speed and laser power, pause or cancel the engraving process.



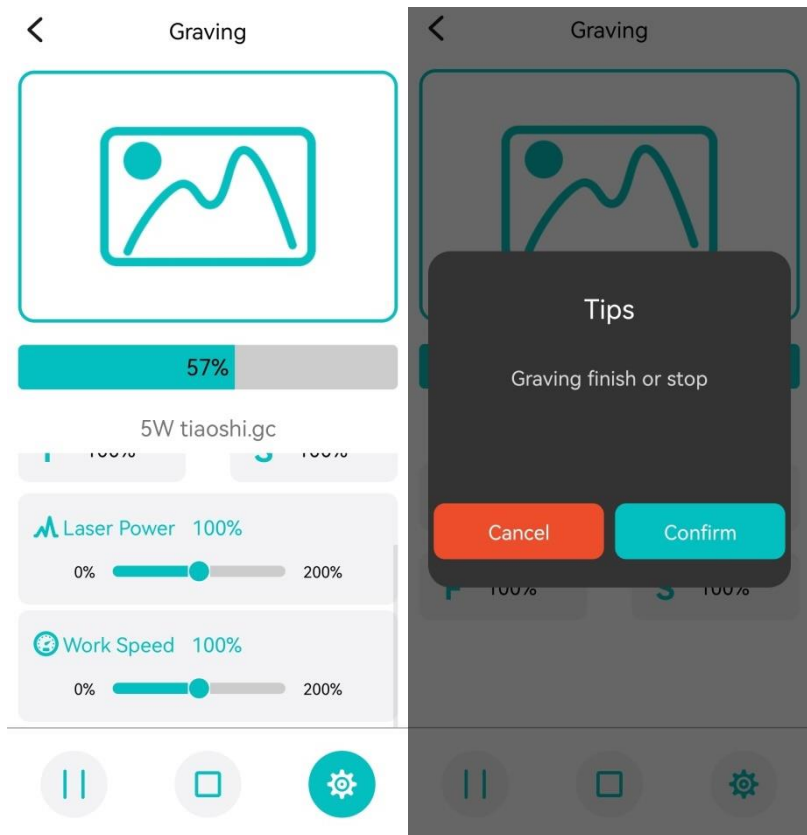
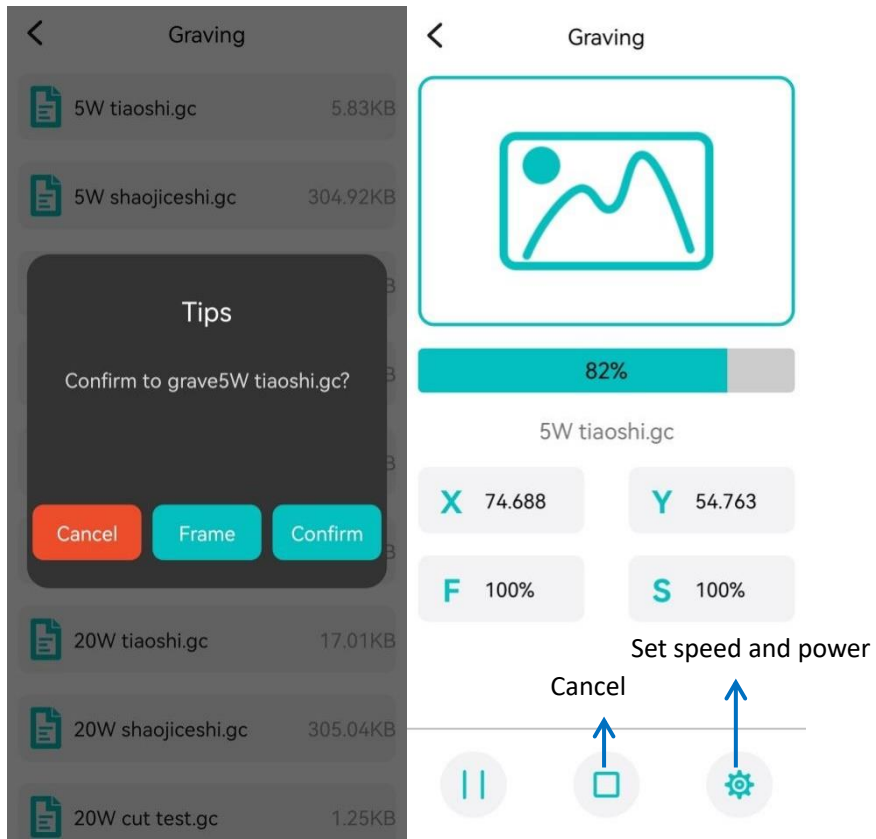

**Note: To use APP for engraving, it needs to insert the SD card into the motherboard firstly to ensure that the data can be received normally; otherwise it will prompt upload error.**

## **D.FAQ**

**Question 1: Are there recommended engraving and cutting parameters?**

Please refer to the table “LONGER Laser Engraver Material Profiles” which describes the common materials engraving and cutting parameters for **RAY5**.

If there is no information you need. Please wait for our updates in the future.

**Question 2: The engraved pattern appears vibration, or is not closed?**

- Adjust the eccentric nut to make the parts move smoothly without shaking.
- Re-tension the timing belt.
- Adjust the synchronous wheel to prevent the synchronous belt from rubbing against the side of the synchronous wheel during movement.

### Question 3: How about the warranty policy?

For LONGER official stores and LONGER designated distributors, **RAY5** has a One-year International Limited Manufacturer warranty from the date of purchase of **RAY5**.

Please note the following warranty terms. One-year International Limited Manufacturer Warranty means that LONGER will provide the following free warranty services:

- Diagnostics and Evaluation.
- Technical Support.
- Replacement Parts under Warranty terms.

How to handle a warranty case:

Any warranty case must be submitted to our official support channels (Email: [support@longer3d.com](mailto:support@longer3d.com)). In case the product was bought from a reseller, contact us first so that we can help you diagnose the problem, then turn to your reseller for spare parts if needed.

Documentation needed for a warranty case:

1. Machine purchase order number and channel, nameplate number on the machine.
2. A brief description of the problem along with the clear evidence of its presence (e.g., photos or videos).
3. On the initial contact for customer support further tests and diagnostic steps might be required to identify the cause of the

problem.

4. Some parts of the **RAY5** inevitably “get used up” over time. For these parts, specific conditions apply, unless failure has occurred due to a defect in materials or workmanship.

Part	Warranty Limitation
Motherboard	One-year International Limited Manufacturer Warranty
Motor	One-year International Limited Manufacturer Warranty
Longer Laser Module	One-year International Limited Manufacturer Warranty
Touch Screen	One-year International Limited Manufacturer Warranty
Power Adapter	One-year International Limited Manufacturer Warranty
Chrome-Plated Rod	Warranty does not apply on normal wear and tear
2020 Profile	Warranty does not apply on normal wear and tear
Coupling	Warranty does not apply on normal wear and tear
Eccentric Nut	Warranty does not apply on normal wear and tear
Bearing	Warranty does not apply on normal wear and tear
L-Shaped Right-Angle Foot Slot	Warranty does not apply on normal wear and tear
Goggles	Warranty does not apply on normal wear and tear
Brush	Warranty does not apply on normal wear and tear
Board\ Acrylic Board\ Stainless Steel Plate	Warranty does not apply on normal wear and tear
Linear Bearing Wheels	Warranty does not apply on normal wear and tear
GT2 Timing Belts	Warranty does not apply on normal wear and tear
Powder-Coated Aluminum Extrusion	Warranty does not apply on normal wear and tear
Cables & Drag Chain	Warranty does not apply on normal wear and tear
Cosmetic Appearance & Logos	Warranty does not apply on normal wear and tear

**Note:**

- The warranty does not cover normal, expected wear and tear caused by using the **RAY5** for its intended purpose.
- In case we have provided a free replacement part, the warranty does not reset. The original warranty period still applies.

This warranty is voided by:

- 
- Any damages caused by improper assembly of the product.
  - Any damage caused by improper use, maintenance, or operation of the engraver.
  - Any damage caused by long-term lack of maintenance.
  - Using the **RAY5** in improper conditions (temperature, dustiness...).
  - Upgrades, modifications, or add-ons that are not officially supported.

Our Technical Support Team is always available to help you out under any circumstances, even if the issue is not covered under warranty.

#### **Question 4: How to maintain RAY5 laser module?**

RAY5's lasers are carefully designed to resist stains, but after long-term use, there may still be dust and grease on the laser hood, air guide, and even the lens. This will affect the appearance and performance. It is recommended to clean the laser regularly to keep it in good performance. You need to perform the following steps to clean the laser.

Preparation: hex wrench, non-woven fabric, alcohol/isopropanol solution.

Start:

1. Remove the laser hood and air guide
2. Dip a little alcohol/isopropyl alcohol solution with a non-woven fabric
3. Carefully wipe the laser lens with a non-woven fabric
4. Reinstall the laser hood and air guide

Warning: Excess solution may immerse inside the laser and cause damage to the laser.

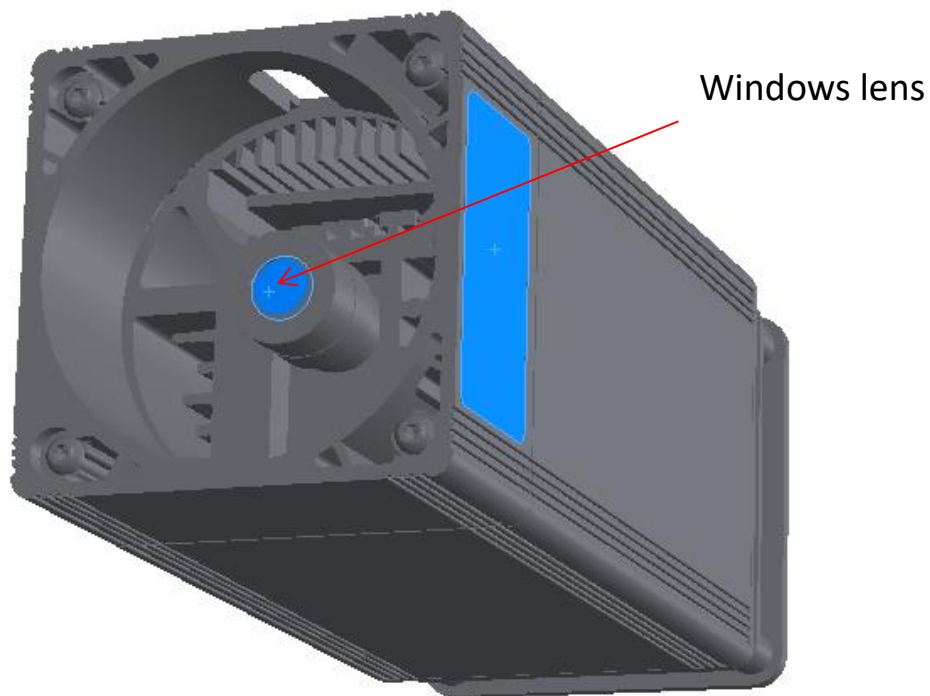

RAY5 20W laser module

### Question 5: How to solve alarm 2 error or hard limit?

ALARM:2

G-code motion target exceeds machine travel. Machine position safely retained. Alarm may be unlocked. (Right-click the 'Devices' button to reset the connection)

On or near line 2:

It adds two limit switch in RAY5 20W laser engraver compared with RAY5 5W or 10W, the firmware has hard limit and soft limit features to locate the laser module position precisely. The position of the laser module is assumed to be the home position by default when powered on. So the engraver will trigger the alarm 2 or hard limit error if the laser head is moved in the X or Y negative direction at this time. Then it needs to home the engraver as shown in the picture below.

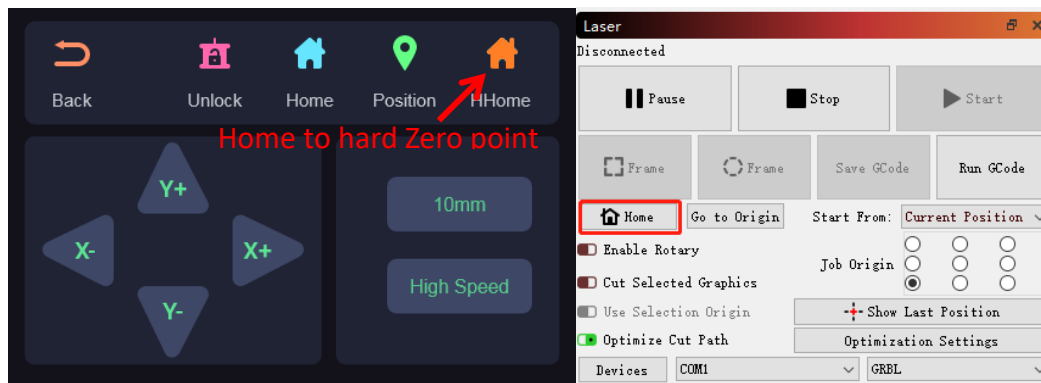

### Question 6: How to solve the upload error of the APP?

To use APP for engraving, it needs to insert the SD card into the motherboard firstly to ensure that the data can be received normally; otherwise it will prompt upload error.

Thank you for purchasing LONGER products! Under normal usage and service, the products and its parts have a warranty period up to one year. If you encounter any problems, please send an email to [support@longer3d.com](mailto:support@longer3d.com) to report any issue with LONGER products. Our professional after-sale service would respond within 24 hours and help you to solve the issues.

---

i