

### Advanced Design with Automatic Teach Function

- Retroreflective models have a sensing distance of 10 m
- Teach function up to 2 m diffuse
- Zone mode for precise sensing
- M12 connector and pre-leaded models
- IEC IP67
- Light-ON/Dark-ON operation, NPN/PNP output are switch selectable
- Relay or transistor output models





## Ordering Information

### ■ SENSORS

Type	Supply voltage	Output	Connection	Sensing range	Standard target	Timer function	Part number	
Polarized retroreflective	10-30 VDC	NPN/PNP	Pre-leaded	500 mm to 10 m with E39-R2 reflector (included)	80 mm dia.	—	<b>E3G-R13</b>	
			Connector				<b>E3G-R17</b>	
	12-240 VDC, 24-240 VAC	Relay	Terminal block				ON or OFF delay 0-5s, adjustable	<b>E3G-MR19-US</b>
								<b>E3G-MR19T-US</b>
Diffuse reflective	10-30 VDC	NPN/PNP	Pre-leaded	200 mm to 2 m	300 x 300 mm Kodak 90% white card	—	<b>E3G-L73</b>	
			Connector				<b>E3G-L77</b>	
	12-240 VDC, 24-240 VAC	Relay	Terminal block				ON or OFF delay 0-5s, adjustable	<b>E3G-ML79-US</b>
								<b>E3G-ML79T-US</b>



### ■ CONNECTOR CORDSETS

#### Connector Cables

Shape	Length	Conductors	Part number
Straight 	2 m	Three	<b>XS2F-D421-DC0-A</b>
	5 m		<b>XS2F-D421-GC0-A</b>
Right angle 	2 m		<b>XS2F-D422-DC0-A</b>
	5 m		<b>XS2F-D422-GC0-A</b>

## ■ ACCESSORIES (ORDER SEPARATELY)

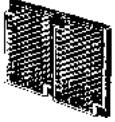



### Reflectors

Shape	Sensing distance (typical)	Remarks	Part number
	500 mm to 10 m	Included with E3G-R□□ and E3G-MR□□	<b>E39-R2</b>
	100 mm to 6 m	---	<b>E39-R1</b>

### Terminal Protection Cover for Side-pullout Cable (required when side-exit is desired for cable)

Shape	Applicable model	Remarks	Part number
	E3G-MR19 (T), ML79 (T)	Provided with rubber bushing and cap for pullout prevention in vertical direction	<b>E39-L129</b>

### Mounting Brackets (not included, order separately)

Shape	Applicable model	Remarks	Part number
	Pre-leaded and connector models		
	E3G-R1□ E3G-L7□	---	<b>E39-L131</b>
		Rear-mounting use	<b>E39-L132</b>
	Terminal block models		
	E3G-MR19 (T) E3G-ML79 (T)	Cable pulled out in the downward direction	<b>E39-L135</b>
	E3G-MR19 (T) E3G-ML79 (T)	---	<b>E39-L136</b>

# Specifications

## ■ RATINGS/CHARACTERISTICS

Sensing method	Retroreflective (polarized)				Diffuse			
Part number	E3G-R13	E3G-R17	E3G-MR19	E3G-MR19T	E3G-L73	E3G-L77	E3G-ML79	E3G-ML79T
Sensing distance	0.5 to 10 m (1.64 to 32.8 ft) using E39-R2				0.2 to 2 m (0.66 to 6.56 ft)			
Setting distance	---				0.5 to 2 m (1.64 to 6.56 ft)			
Standard sensing object	Opaque: 80 dia. min.				Kodak 90% white card 300 x 300 mm			
Hysteresis (typical)	---				10% of setting distance			
Directional angle	Sensor: 1° to 5° Reflector: 40° min.				---			
Reflectivity characteristics (black/white error)	---				±10% max. (at 1-m sensing distance)			
Light source (wavelength)	Red LED (700 nm)				Infrared LED (860 nm)			
Spot size	---				70 dia. max. at 1-m sensing distance			
Supply voltage	10 to 30 VDC including 10% (p-p) ripple		12 to 240 VDC ±10% including 10% (p-p) max. ripple 24 to 240 VAC ±10% at 50/60 Hz		10 to 30 VDC including 10% (p-p) ripple		12 to 240 VDC ±10% including 10% (p-p) max. ripple 24 to 240 VAC ±10% at 50/60 Hz	
Current consumption	50 mA max.		2 W max.		60 mA max.		2 W max.	
Output	30 VDC max. Load current: 100 mA max. Residual voltage: NPN output: 1.2 V max. PNP output: 2.0 V max. Open collector output (NPN/PNP selectable)		Relay output: SPDT, 3 A (cos φ = 1) max. at 250 VAC or 3 A max. at 30 VDC		Load power supply voltage: 30 VDC max. Load current: 100 mA max. Residual voltage: NPN output: 1.2 V max. PNP output: 2.0 V max. Open collector output (NPN/PNP selectable)		Relay output: SPDT, 3 A (cos φ = 1) max. at 250 VAC or 3 A max. at 30 VDC	
Operation mode	Light-ON/Dark-ON switch selectable							
Life expectancy (relay output)	Mechanical: 50,000,000 operations min. (switching frequency: 18,000 operations/h) Electrical: 100,000 operations min. (switching frequency: 1,800 operations/h)							
Circuit protection	Protection from reversed power supply connection, load short-circuit, and mutual interference		Protection from mutual interference		Protection from reversed power supply connection, load short-circuit, and mutual interference		Protection from mutual interference	

(This table continues on the next page.)

Specifications Table - continued from previous page

Sensing method	Retroreflective (polarized)				Diffuse			
Part number	E3G-R13	E3G-R17	E3G-MR19	E3G-MR19T	E3G-L73	E3G-L77	E3G-ML79	E3G-ML79T
Response time	1 ms		30 ms max.		5 ms		30 ms max.	
Sensitivity adjustment	One-turn potentiometer				Teaching (in NORMAL or ZONE mode)			
Ambient illumination (receiver side)	Incandescent lamp: 3,000 lx max. Sunlight: 10,000 lx max.							
Ambient temperature	Operating: -25°C to 55°C (-13 to 131°F) Storage: -30°C to 70°C (-22 to 158°F) with no icing or condensation							
Relative humidity	Operating: 35% to 85%/ Storage: 35% to 95% with no condensation							
Insulation resistance	20 MΩ min. at 500 VDC							
Dielectric strength	1,000 VAC, 50/60 Hz for 1 min		2,000 VAC, 50/60 Hz for 1 min		1,000 VAC, 50/60 Hz for 1 min		2,000 VAC, 50/60 Hz for 1 min	
Vibration resistance	10 to 55 Hz, 1.5-mm double amplitude for 2 hours each in X, Y, and Z axes							
Shock resistance	500 m/s <sup>2</sup> 3 times each in X, Y, and Z axes							
Degree of protection	IP67							
Connection method	2 m cable	M12 connector	Terminal block		2 m cable	M12 connector	Terminal block	
Weight (packed state)	Approx. 150 g	Approx. 50 g	Approx. 150 g		Approx. 50 g	Approx. 150 g		
Material	Case	PBT (polybutylene terephthalate)						
	Lens	Acrylic (PMMA)						
	Mounting bracket	Stainless steel (SUS304), order separately						

## Engineering Data

### ■ RETROREFLECTIVE MODELS, E3G-R/MR

#### Lateral Movement

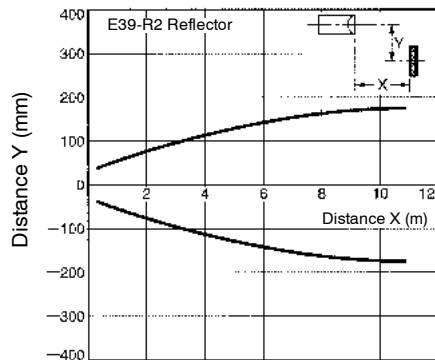

#### Excess Gain

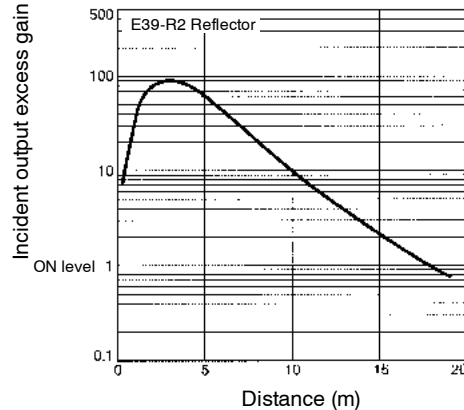

■ DIFFUSE MODELS, E3G-L/ML

Spot Diameter vs. Sensing Distance

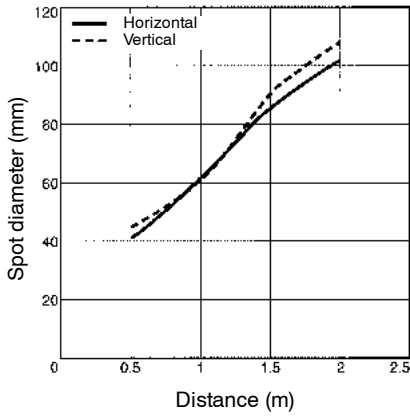

Sensing Zone in NORMAL Mode

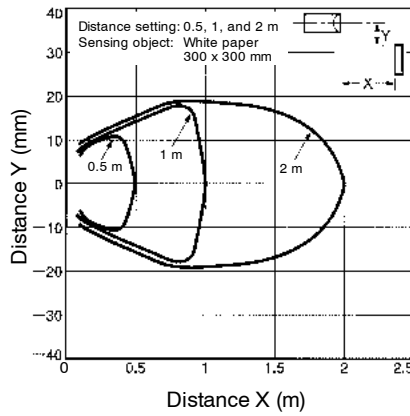

Sensing Zone in ZONE Mode

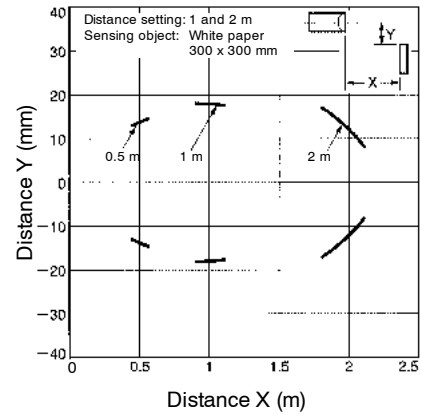

Sensing Object Size vs. Setting Distance

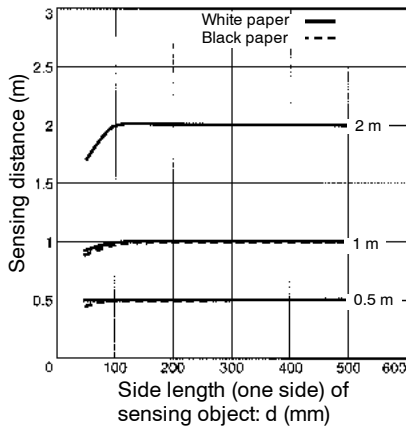

Sensing Object Angle Characteristics (Up and Down)

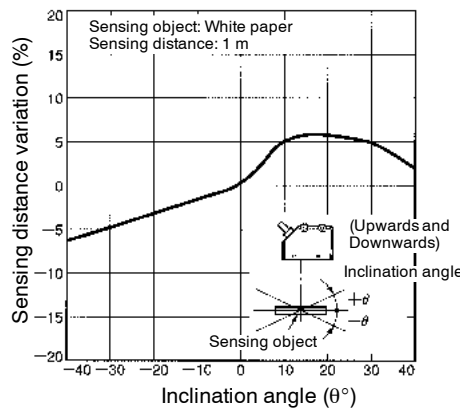

Sensing Object Angle Characteristics (Left and Right)

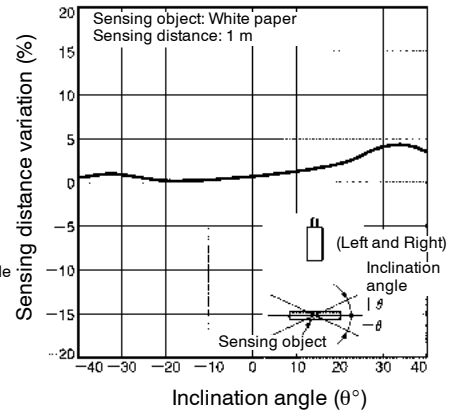

Sensing Distance vs. Sensing Object Material (at 1-m Setting Distance)

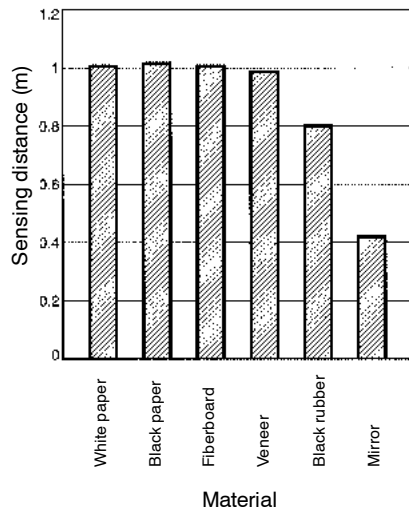

Sensing Distance vs. Sensing Object Material (at 500-mm Setting Distance)

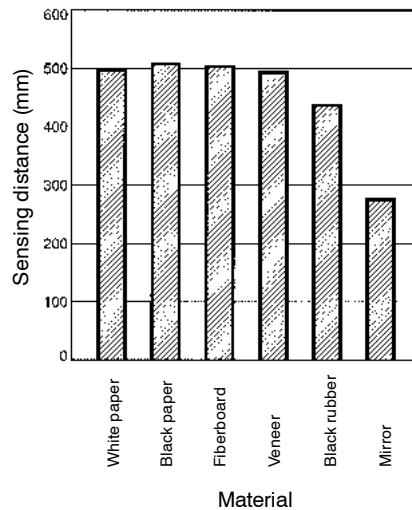

Close-range Characteristics

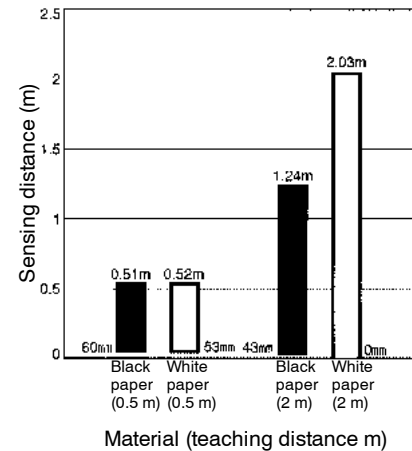

# Operation

## ■ OUTPUT CIRCUITS

### NPN/PNP Selectable

Part number	E3G-R13 E3G-R17 E3G-L73 E3G-L77			
Output transistor status	Light ON	Dark ON	Light ON	Dark ON
Timing chart				
Output configuration	NPN		PNP	
Output circuit	<p style="text-align: center;"><b>Connector Pin Arrangement</b></p>		<p style="text-align: center;"><b>Connector Pin Arrangement</b></p>	

Relay Output

Timer function	---	
Part number	E3G-MR19 E3G-ML79	
Timing chart		
Mode selector	Light-ON (L/ON)	Dark-ON (D/ON)

Timer function	ON or OFF delay 0 to 5 s (adjustable)	
Part number	E3G-MR19T E3G-ML79T	
Timing chart		
Mode selector	Light-ON (L/ON)	Dark-ON (D/ON)

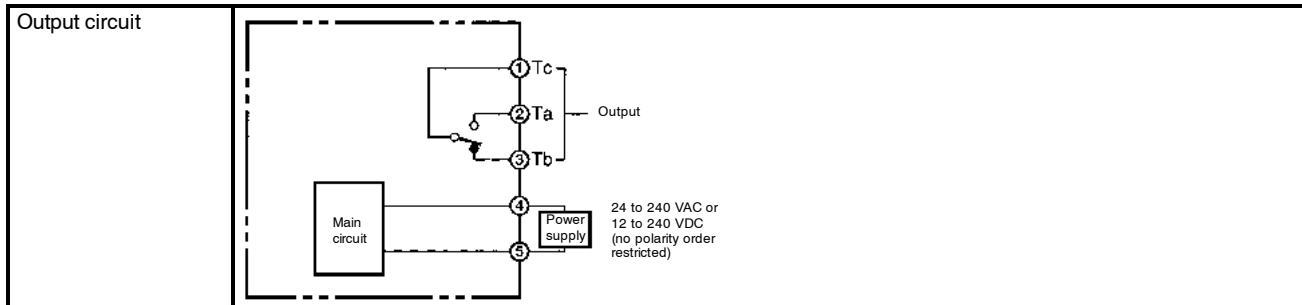

Note: Td1, Td2: Delay time (0 to 5 s)  
 T<sub>1</sub>: A period longer than the delay time.  
 T<sub>2</sub>: A period shorter than the delay time.  
 For ON- and OFF-delay timers, Td1 and Td2 are independently variable.

CONNECTOR

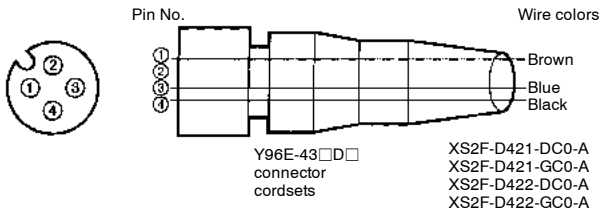

Classification	Wire color	Connector pin No.	Use
DC	Brown	1	Power supply (+V)
	---	2	Not used
	Blue	3	Power supply (0 V)
	Black	4	Output

# Nomenclature

## ■ CONTROL PANELS

### Retroreflective

E3G-R13 (Pre-leaded Model)  
E3G-R17 (Connector Model)

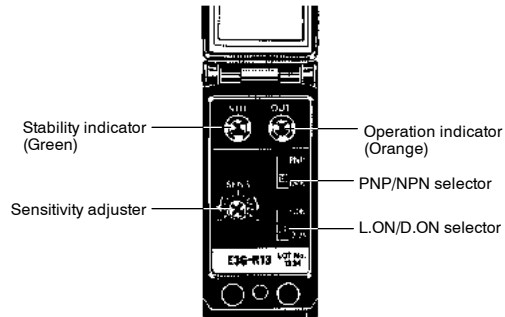

### E3G-MR19 (Terminal Block Model)

E3G-MR19T (Terminal Block Model with Timer)

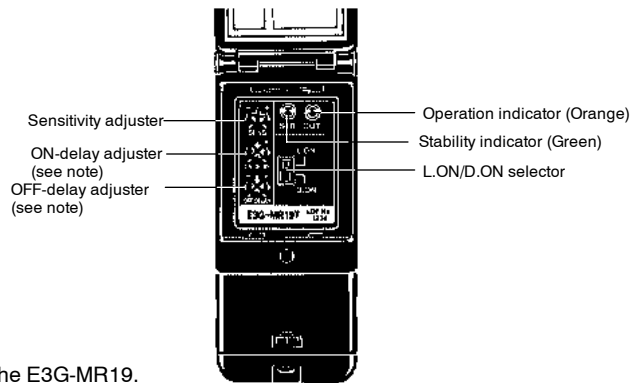

Note: The ON- or OFF-delay adjuster is not available with the E3G-MR19.

### Diffuse

E3G-L73 (Pre-leaded Model)  
E3G-L77 (Connector Model)

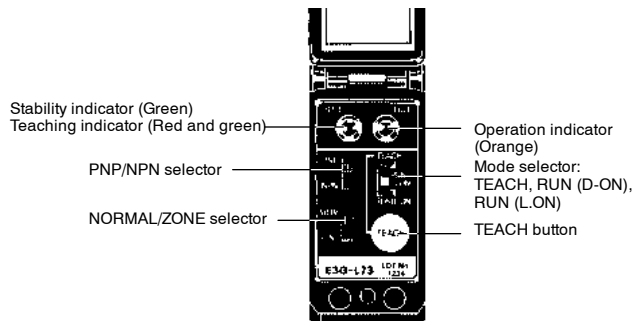

### E3G-ML79 (Terminal Block Model)

E3G-ML79T (Terminal Block Model with Timer)

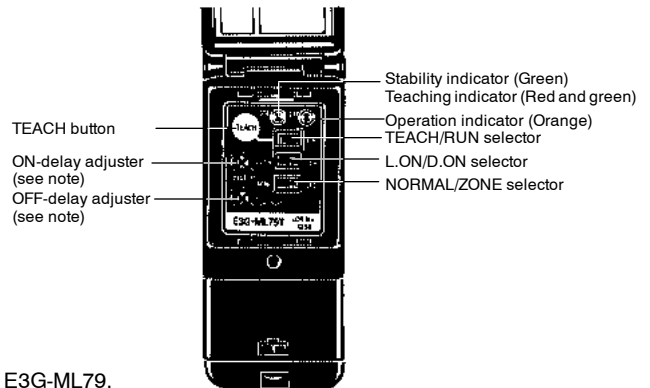

Note: The ON- or OFF-delay adjuster is not available with the E3G-ML79.



# Installation

## ■ POWER SUPPLY

A power supply with full-wave rectification can be connected to the E3G-MR19(T).

## ■ WIRING

The tensile strength of the cable during operation should not exceed the values shown below.

Part number	Tensile strength
E3G-R13, E3G-MR19(T)	50 N max.
E3G-R17	10 N max.

## ■ ADJUSTMENTS

### Indicators

The following illustration indicates the operation levels of the E3G.

Set the E3G so that it will work within the stable operation range.

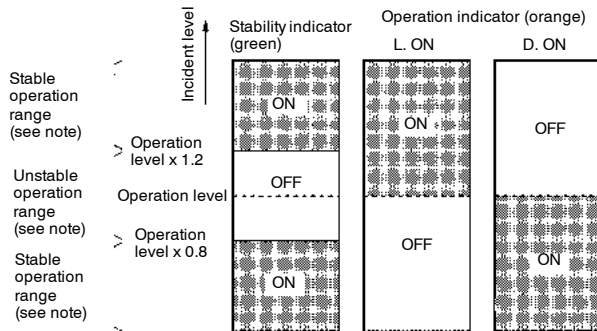

**Note:** If the operation level is set to the stable operation range, the E3G will operate with the highest reliability and without being influenced by temperature change, voltage fluctuation, dust, or setting change. If the operation level cannot be set to the stable operation range, pay close attention to environmental changes while operating the E3G.

## ■ MOUNTING DIFFUSE MODELS

### Mounting Directions

Make sure that the sensing side of the Sensor is parallel with the surface of each sensing object. Do not tilt the Sensor towards the sensing object.

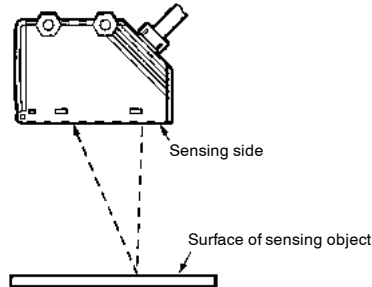

If the sensing object has a glossy surface, tilt the Sensor by 5° to 10° as shown below, provided that the Sensor is not influenced by any background objects.

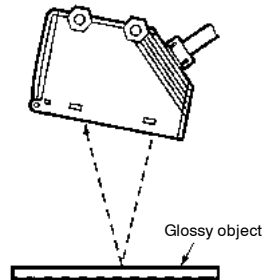

If there is a mirror-like object below the Sensor, the Sensor may not be in stable operation. Therefore, tilt the Sensor or keep the Sensor a distance away from the mirror-like object as shown below.

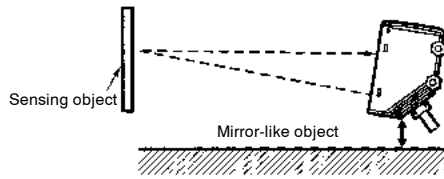

Make sure not to install the Sensor in the incorrect direction. Refer to the following.

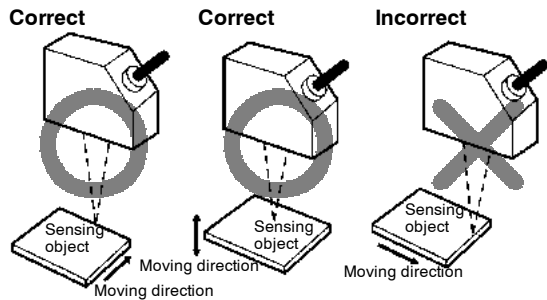

## ■ ADJUSTMENTS FOR DIFFUSE MODELS

### Adjustment Steps

1	Install, wire, and turn ON the Sensor.
2	Perform sensitivity adjustments (teaching). Refer to <i>Distance Setting (Teaching)</i> below.
3	Check that the mode selector is set to RUN.

Install the Sensor as shown in the following if each sensing object greatly differs in color or material.

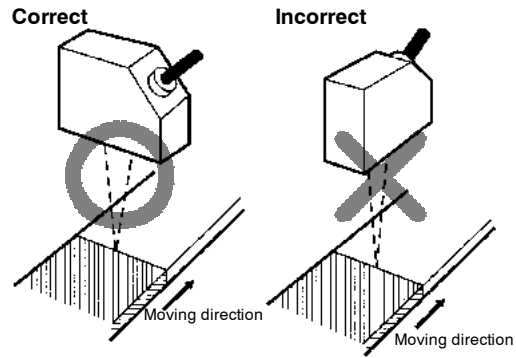

## ■ OTHERS

If a teaching data error occurs with the operation indicator flashing due to a power failure or static noise, perform the teaching operation of the Sensor again.

## DISTANCE SETTING (TEACHING)

Select the most appropriate teaching method in reference to the following descriptions.

Application	Teaching without sensing objects (i.e., teaching the background).	Setting a threshold in the middle between the background and sensing object for operation.	Detection of glossy objects in front of the background.	Setting the maximum sensing distance of the Sensor.
-------------	---	--	---	---

Teaching	Normal one-point teaching	Normal two-point teaching	Zone teaching	Maximum distance setting (in normal mode)
Setting method	Press the TEACH button with the background object.	Press the TEACH button with the background object and with the sensing object.	Press the TEACH button with the background object (conveyor, etc.).	Press the TEACH button for longer than three seconds.
Set threshold	Threshold (a) is set to a distance in front of the background of 20% of the background distance.	Threshold (a) is set approximately in the middle between the background and sensing object.	Thresholds (a and b) are set in the sensing distance on condition that the difference between these thresholds are approximately 10% of the whole sensing distance.	The threshold is set so that the stability indicator will turn ON at approximately 2 m if the sensing object is white paper.
Output ON range	The output is ON between the Sensor and La.	The output is ON between the Sensor and La.	The output is ON between La and Lb.	The output is ON whenever the sensing object is located between the Sensor and at a distance of 2.2 m.

La: Distance equivalent to threshold (a)

Lb: Distance equivalent to threshold (b)

### NORMAL MODE

#### 1. Normal One-point Teaching

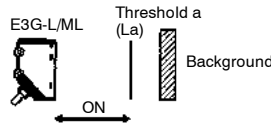

#### 2. Normal Two-point Teaching

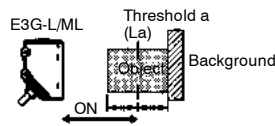

### ZONE MODE

#### Zone Teaching

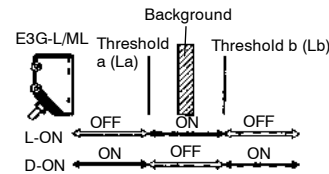

#### Normal One-point Teaching

Procedure	Operation
	1. Set the mode selector to TEACH.
	2. Set the NORMAL/ZONE mode selector to NORMAL.
	3. Press the TEACH button with no sensing object (i.e., teach the background). The teaching indicator (red) will turn ON.
4. Set the mode selector to RUN. (Set to L-ON or D-ON mode.)	

**Note:** Perform normal one-point teaching with the background.

#### Zone Teaching

Procedure	Operation
	1. Set the mode selector to TEACH.
	2. Set the NORMAL/ZONE mode selector to ZONE.
	3. Press the TEACH button with the background. <ul style="list-style-type: none"> <li>The teaching indicator (red) will turn ON first. Then the teaching indicator (green) will turn ON.</li> </ul>
4. Set the mode selector to RUN. (Set to L-ON or D-ON mode.)	

**Note:** Perform zone teaching with the background.

#### Normal Two-point Teaching

Procedure	Operation
	1. Set the mode selector to TEACH.
	2. Set the NORMAL/ZONE mode selector to NORMAL.
	3. Press the TEACH button with a sensing object located at the sensing position. The teaching indicator (red) will turn ON.
	4. Move the sensing object and press the TEACH button with the background. <ul style="list-style-type: none"> <li>If the teaching is successful, the teaching indicator (green) will turn ON.</li> <li>If the teaching is not successful, the teaching indicator (red) will start to flash.</li> </ul>
5. If the teaching is successful, set the mode selector to RUN to complete the teaching operation. Set the E3G to light- or dark-ON mode with the mode selector according to the application. If the teaching is not successful, change the set distance and object sensing position and repeat two-point teaching from step 3.	

#### Maximum Distance Setting (in Normal Mode)

Procedure	Operation
	1. Set the mode selector to TEACH.
	2. Set the NORMAL/ZONE mode selector to NORMAL.
	3. Press the TEACH button for 3 s or more. <ul style="list-style-type: none"> <li>The teaching indicator (red) will turn ON.</li> <li>The teaching indicator (green) will turn ON in 3 s. This means that teaching was successful.</li> </ul>
4. If the teaching is successful, set the mode selector to RUN to complete the teaching operation. (Set to L-ON or D-ON mode.)	

## ■ TERMINAL BLOCK MODELS

E3G-MR□□□, E3G-ML□□□

### Wiring

The cable with an external diameter of 6 to 8 mm is recommended.

Be sure to attach the cover with screws securely in order to maintain the water- and dust-resistive properties of the product.

### Terminal Cover

Do not tighten the terminal protection cover with wires pinched between the Sensor and the cover in order to maintain the water- and dust-resistive properties of the product.

#### Recommended Example

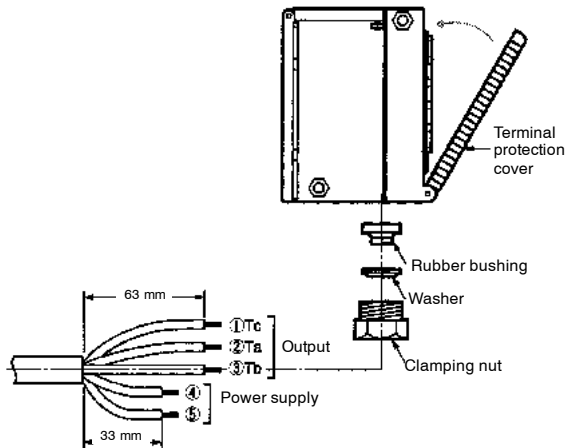

## ■ CHANGING CABLE EXIT

### Procedure

1. Remove the present cover. (Item 1 below)
2. Attach the E39-L129 Terminal Protection Cover for side-pull-out cable.
3. Remove the clamping nut, washer, and rubber bushing of the E3G. These are used for the side-pullout cable.
4. Attach the rubber bushing and cap provided with the E39-L129 to the E3G as replacements.

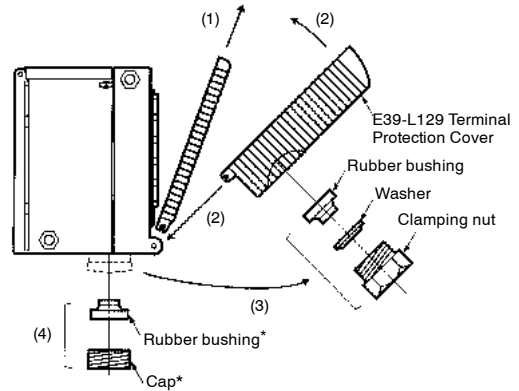

Note: \*Provided with the E39-L129.

# Dimensions

Unit: mm (inch)

## SENSORS

### E3G-R13 and E3G-L73 Pre-lead Models

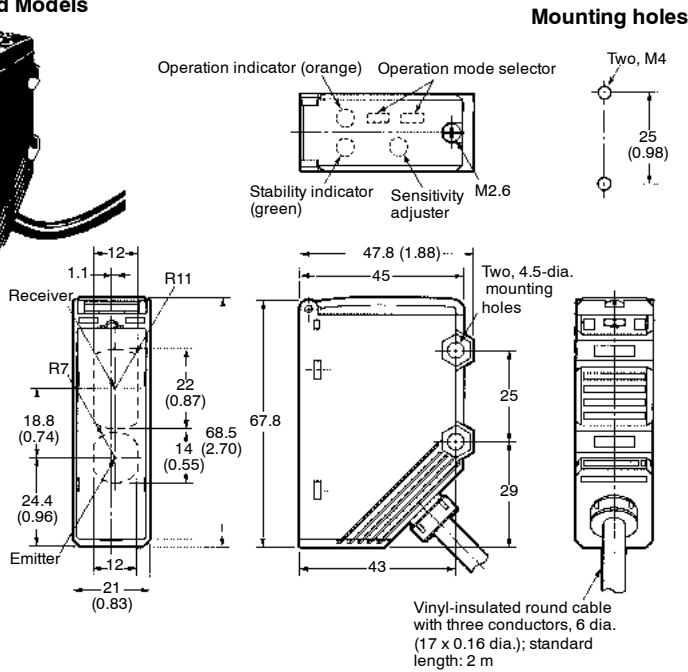
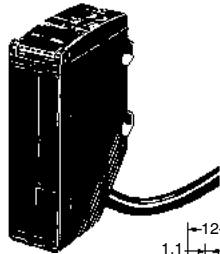

### E3G-R17 and E3G-L77 Connector Models



**Note:** All dimensions other than the ones specified below are the same as the corresponding dimensions of E3G-R13.

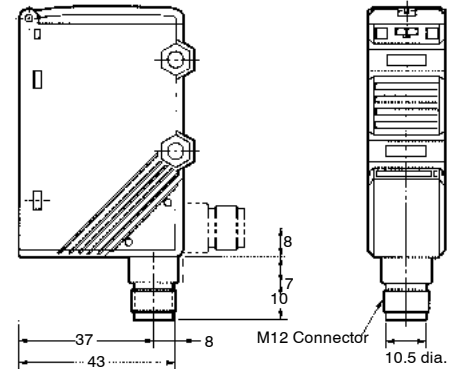

### E3G-MR19, E3G-MR19T, E3G-ML79 and E3G-ML79T Terminal Block Models

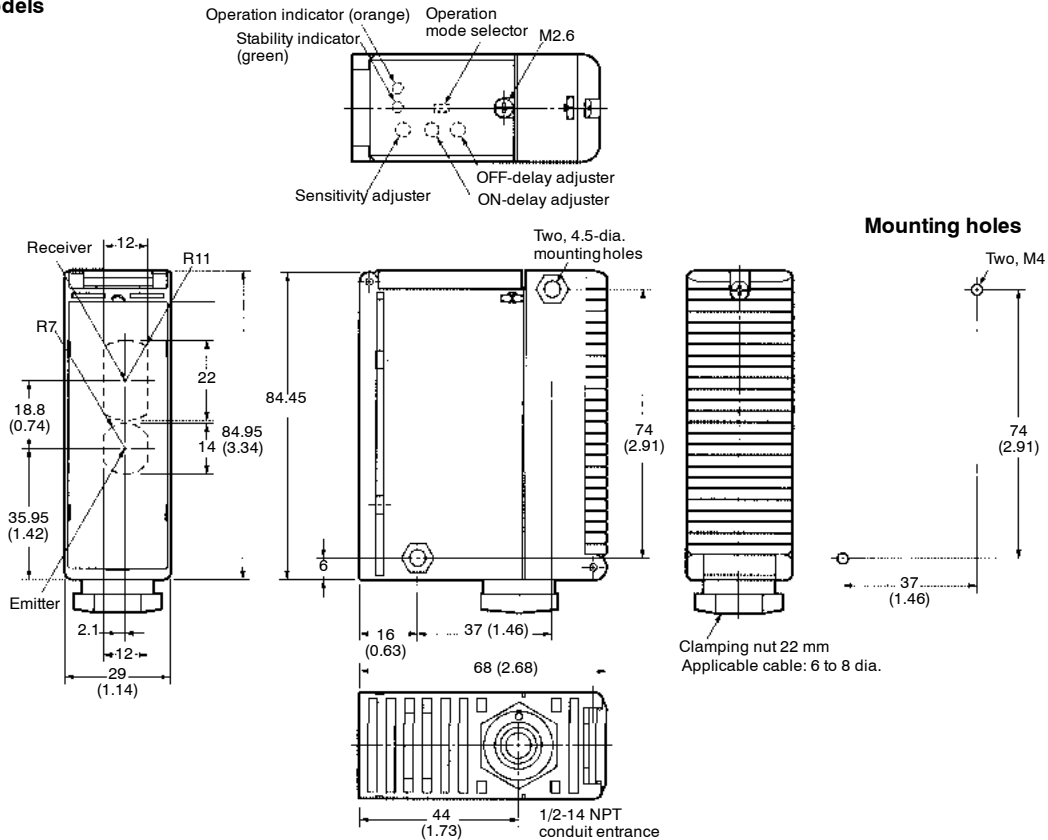
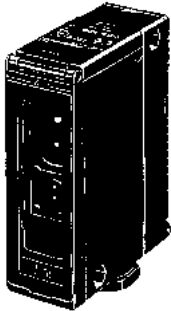

■ ACCESSORIES (ORDER SEPARATELY)

Reflectors

E39-R2

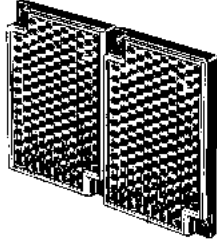

Material  
Surface: Acrylic resin  
Backside: ABS resin

Note: Supplied with E3G-R□□, E3G-MR□□, and E3G-MR□□-US.

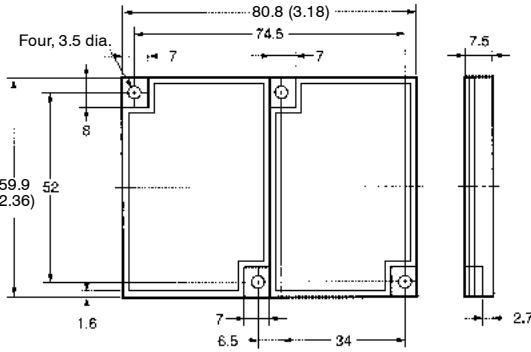

E39-R1

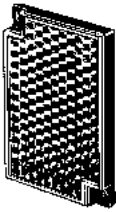

Material  
Surface: Acrylic resin  
Backside: ABS resin

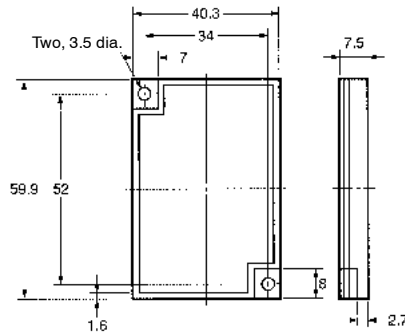

Terminal Protection Cover for Side-pullout Cable

E39-L129

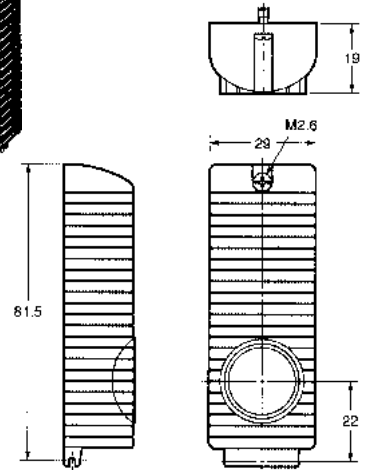

- Note: 1. The cover is provided with a rubber bushing and cap to prevent the cable from being pulled out vertically.
- 2. Refer to page 13 for the mounting method of the product.

■ MOUNTING BRACKETS (NOT INCLUDED, ORDER SEPARATELY)

E39-L131

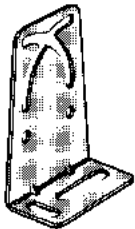

Material: Stainless steel (SUS304)

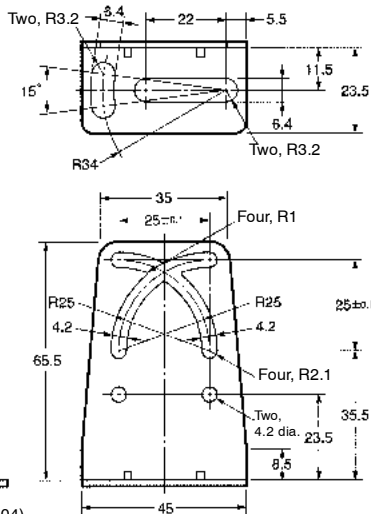

E39-L132

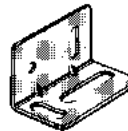

Material: Stainless steel (SUS304)

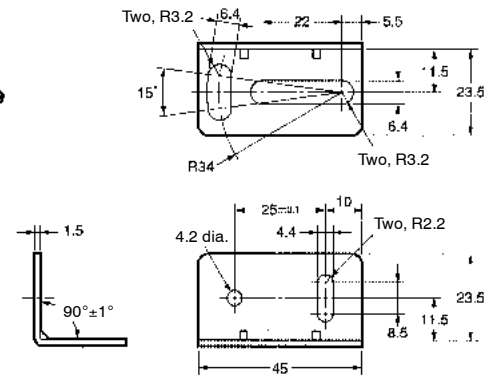

E39-L135

E39-L136

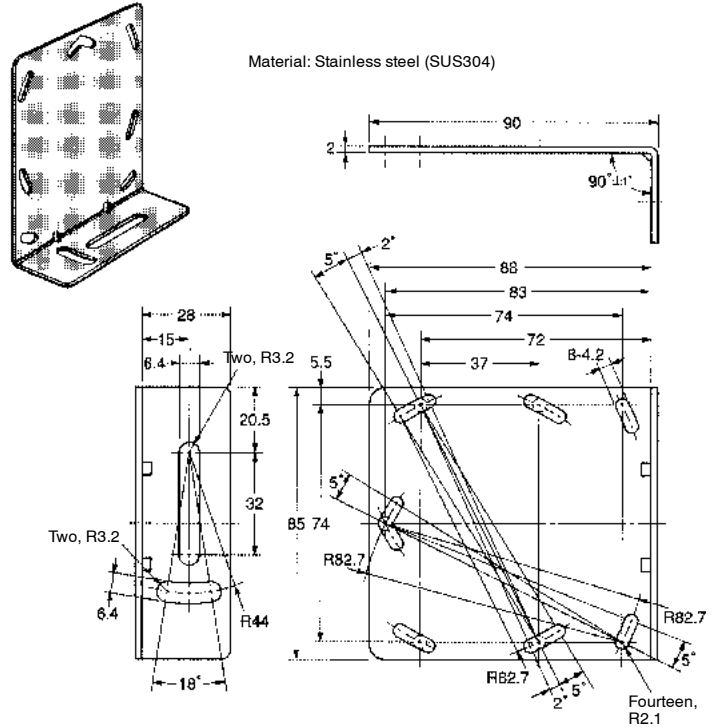
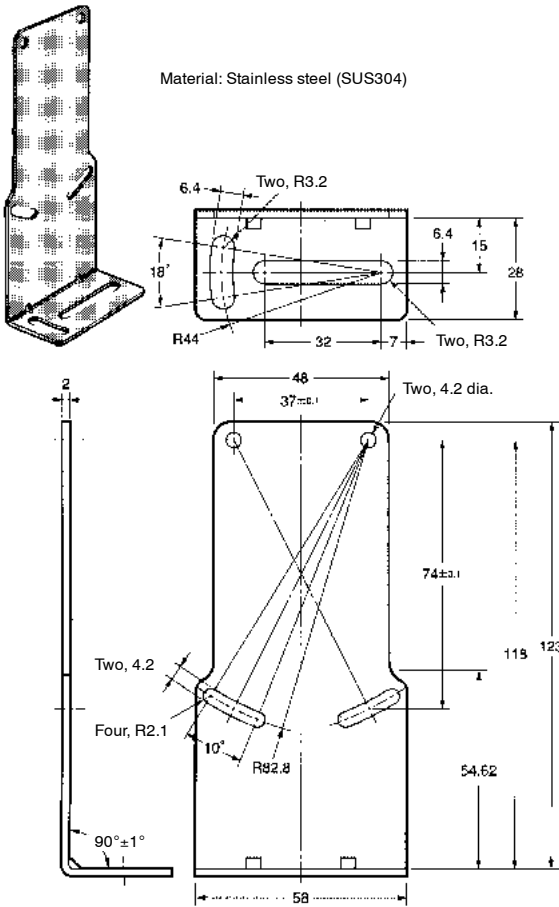

CONNECTOR CORDSETS

**Straight**  
 XS2F-D421-DC0-A (L=2 m)  
 XS2F-D421-GC0-A (L=5 m)

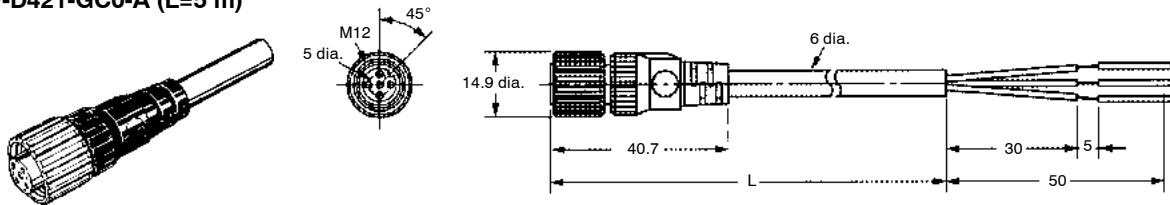

**Right angle**  
 XS2F-D422-DC0-A (L=2 m)  
 XS2F-D422-GC0-A (L=5 m)

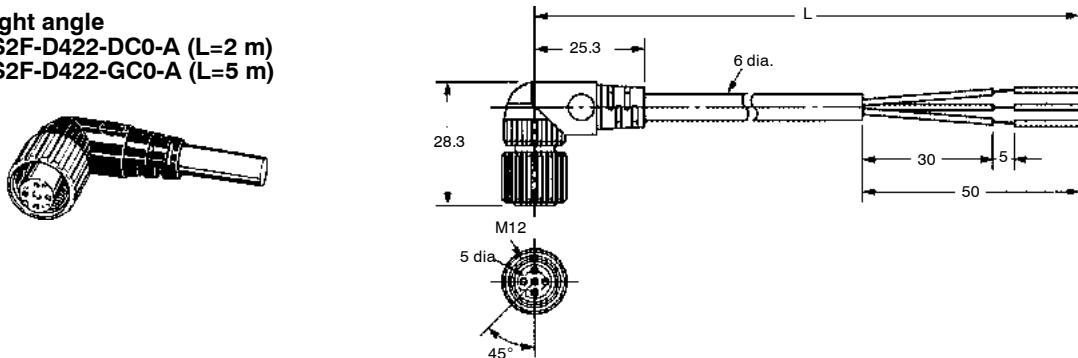

## Precautions

Do not ignore the following items that are essential for securing safety during Sensor operation.

- Do not use the Sensor in locations with explosive or flammable gas.
- Do not use the Sensor in the water or electrically conductive solutions.
- Do not disassemble, repair, or modify the product.

### ■ DESIGNING

#### Load Relay Contact

If E3G is connected to an inductive load with contacts that spark when the load is turned OFF (e.g., a contactor or valve), the normally-closed side may be turned ON before the normally-open side is turned OFF or vice-versa. If both normally-open output and normally-closed output are used simultaneously, apply an surge suppressor to the load.

#### Stabilization on Power-up

The Sensor needs 100 ms to be ready to operate after it is turned ON. The devices connected to E3G wait until the Sensor is ready to operate. If the Sensor and load are connected to separate power supplies, be sure to turn ON the Sensor first.

#### Power OFF

A single pulse signal may be output from the Sensor immediately after it is turned OFF. This will occur more frequently if a timer or counter is connected to the Sensor and power is supplied to the timer or counter independently. Be sure to supply power to the timer or counter from the built-in power supply of the Sensor.

#### Power Supply

If a standard switching regulator is used, be sure to ground the FG (frame ground) and G (ground) terminals, otherwise the Sensor may malfunction due to the switching noise of the regulator.

#### Repeated Cable Bending

Do not bend the sensor cable repeatedly.

#### High-tension Lines

Do not wire power lines or high-tension lines alongside the lines of the Sensor in the same conduit, otherwise the Sensor may be damaged or may malfunction due to induction. Be sure to wire the lines of the Sensor separated from power lines or high-tension lines or laid in an exclusive, shielded conduit.

### ■ WIRING

The E3G has a built-in function to protect the Sensor from load short-circuiting. If load short-circuiting results, the output will be turned OFF. In that case, check the wiring and turn ON the E3G again so that the short-circuit protection circuit will be reset. This function will operate if the output current flow is at least 2.0 times the rated load current. If an inductive load is connected to the E3G, make sure that the inrush current does not exceed 1.2 times the rated load current.

The cable can be extended up to a total length of 100 m, on condition that the thickness of the wire is at least 0.3 mm.

- Make sure that the power supply specifications, such as AC or DC, are correct.
- Do not apply voltage or current exceeding the rated ranges.
- Do not make mistakes in wiring, such as mistakes in polarity.
- Be sure to connect the load correctly.
- Do not short-circuit the load terminals.

### ■ MOUNTING

#### Mounting Conditions

If Sensors are mounted face-to-face, make sure that no optical axes cross each other. Otherwise, mutual interference may result.

Be sure to install the Sensor carefully so that the directional angle range of the Sensor will not be directly exposed to intensive light, such as sunlight, fluorescent light, or incandescent light.

Do not strike the Photoelectric Sensor with a hammer or any other tool during the installation of the Sensor, or the Sensor will lose its water-resistive properties.

Use M4 screws to mount the Sensor.

When mounting the case, make sure that the tightening torque applied to each screw does not exceed 1.2 N • m.

#### M12 Connector

Be sure to connect or disconnect the M12 connector after turning OFF the Sensor.

Be sure to hold the connector cover when connecting or disconnecting the M12 connector.

The M12 connector must be only hand-tightened.

If the M12 connector is not connected securely, the proper degree of protection of the Sensor may not be maintained or the connector may be disconnected due to vibration.

#### Water Resistance

Do not use the product in water, in rain, or outdoors.

Tighten the operation cover screws and terminal block cover screws to a torque of 0.3 to 0.5 N • m in order to ensure water resistivity.

### ■ MAINTENANCE AND INSPECTION

#### Cleaning

Use only water and mild detergent. Do not use harsh chemicals or solvents.

### ■ OPERATING ENVIRONMENT

Do not install the E3G in locations with the following conditions.

- Excessive dust.
- Corrosive gases.
- Directly exposed to sprays of water, oil, or chemicals.
- Directly exposed to vibration or shock.



**NOTE: DIMENSIONS SHOWN ARE IN MILLIMETERS. To convert millimeters to inches divide by 25.4.**

**OMRON**<sup>®</sup>

**OMRON ELECTRONICS LLC**

One East Commerce Drive  
Schaumburg, IL 60173

**1-800-55-OMRON**

**OMRON ON-LINE**

Global - <http://www.omron.com>  
USA - <http://www.omron.com/oei>  
Canada - <http://www.omron.com/oci>

**OMRON CANADA, INC.**

885 Milner Avenue  
Scarborough, Ontario M1B 5V8

**416-286-6465**