

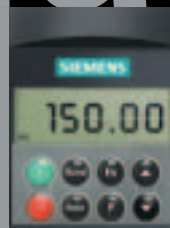

micromaster



MICROMASTER 410/420/430/440
Inverters
0.12 kW to 250 kW



SIEMENS

Trademarks / Internet

® COMBIMASTER, MICROMASTER, MIDIMASTER, SIMOVIS, SITOR and SIVOLT are Siemens registered trademarks. All other products and system names in this catalog are (registered) trademarks of their respective owners and must be treated accordingly.

MICROMASTER 410/420/430/440 Inverters

0.12 kW to 250 kW

Catalog DA 51.2 · 2002
with Changes October 2002

Supersedes: Catalog DA 51.2 · 2001

The products and systems referred to in this catalog are marketed with a DQS certified management system. The DQS certificate is recognized in all IQ Net countries.



Management system

DQS certified according to
DIN EN ISO 9001 Reg. No. 357 QM
DIN EN ISO 14001 Reg. No. 81342-01



BSI certified according to
BS EN ISO 9001 Reg. No. FM 25845

© Siemens AG 2002

Overview

MICROMASTER 410

0.12 kW to 0.75 kW

MICROMASTER 420

0.12 kW to 11 kW

MICROMASTER 430

7.5 kW to 90 kW

MICROMASTER 440

0.12 kW to 250 kW

Appendix

0

1

2

3

4

A

Ha

Au

Overview

Guidelines

	MICROMASTER 410	MICROMASTER 420
Main areas of application	<i>"The low-priced"</i> for variable speeds with three-phase motors on single-phase networks, e.g. with pumps, fans, billboards, cabinets, gate drives and automatic machines	<i>"The universal"</i> for three-phase networks and optional fieldbus interfacing, e.g. for conveyor belts, material transport, pumps, fans and machine tools
Power ranges	0.12 kW to 0.75 kW	0.12 kW to 11 kW
Voltage ranges	100 V to 120 V 1 AC 200 V to 240 V 1 AC	200 V to 240 V 1 AC 200 V to 240 V 3 AC 380 V to 480 V 3 AC
Control	<ul style="list-style-type: none"> • V/f characteristic • Multipoint characteristic (programmable V/f characteristic) • FCC (flux current control) 	<ul style="list-style-type: none"> • V/f characteristic • Multipoint characteristic (programmable V/f characteristic) • FCC (flux current control)
Process control	–	Internal PI controller
Inputs	3 digital inputs 1 analog Input	3 digital inputs 1 analog input
Outputs	1 relay output	1 analog output 1 relay output
Interfacing to automation system	The PLC partner for LOGO! and SIMATIC S7-200	The ideal partner for your automation tasks, whether with SIMATIC S7-200, SIMATIC S7-300/400 (TIA) or SIMOTION
Additional features	<ul style="list-style-type: none"> • Natural ventilation (no fan unit) • Position of connections as with conventional switching elements (e.g. contactors) 	<ul style="list-style-type: none"> • BICO technology
		
	Section 1	Section 2

MICROMASTER 430

"The specialist for pumps and fans"

with optimized OP (manual/automatic switchover), matched software functionality and optimized power efficiency

7.5 kW to 90 kW

380 V to 480 V 3 AC

- V/f characteristic
- Multipoint characteristic (programmable V/f characteristic)
- FCC (flux current control)

Internal PID controller

6 digital inputs
2 analog inputs
1 PTC/KTY input

2 analog outputs
3 relay outputs

The ideal partner for your automation tasks, whether with SIMATIC S7-200, SIMATIC S7-300/400 (TIA) or SIMOTION

- Low-energy mode
- Load torque monitoring (detects running dry of pumps)
- Motor staging



MICROMASTER 440

"The all-purpose"

with advanced vector control (with and without encoder feedback) for versatile applications in sectors such as conveying systems, textiles, elevators, hoisting gear and machine construction

0.12 kW to 250 kW

200 V to 240 V 1 AC
200 V to 240 V 3 AC
380 V to 480 V 3 AC
500 V to 600 V 3 AC

- V/f characteristic
- Multipoint characteristic (programmable V/f characteristic)
- FCC (flux current control)
- Vector control

Internal PID controller (autotuning)

6 digital inputs
2 analog inputs
1 PTC/KTY input

2 analog outputs
3 relay outputs

The ideal partner for your automation tasks, whether with SIMATIC S7-200, SIMATIC S7-300/400 (TIA) or SIMOTION

- 3 selectable drive data sets
- Integrated brake chopper (up to 75 kW)
- Torque control



MICROMASTER 410/420/430/440

Overview

Options

Various options are available for the MICROMASTER:

- Filters
- Chokes
- Operator panels
- PROFIBUS module
- DeviceNet module
- Pulse encoder evaluation module
- Gland plates
- Mounting kits, etc.

Assignment of operator panels and modules to the converter ranges

Accessories	Order No.	MICROMASTER			
		410	420	430	440
Operator panels					
OP	6SE6400-0SP00-0AA0	●			
BOP	6SE6400-0BP00-0AA0		●		●
AOP	6SE6400-0AP00-0AA1		●		●
BOP-2	6SE6400-0BE00-0AA0			●	
Modules					
PROFIBUS	6SE6400-1PB00-0AA0		●	●	●
DeviceNet	6SE6400-1DN00-0AA0		●	●	●
Pulse encoder evaluation	6SE6400-0EN00-0AA0				●

● Possible combination

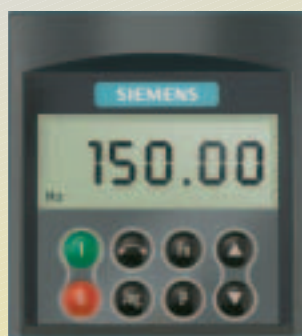

BOP/OP

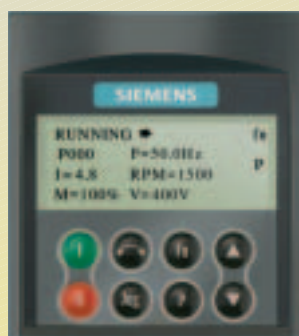

AOP

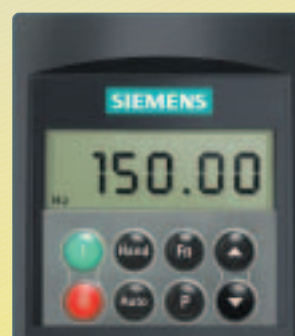

BOP-2

Operator panels



PROFIBUS



DeviceNet



Pulse encoder evaluation

Modules

Inverter

MICROMASTER 410



1/2	Description
1/4	Circuit Diagrams
1/6	Technical Data
1/7	Selection and Ordering Data
1/8	Options
1/10	Dimension Drawings

1



MICROMASTER 410

Description



Frame size AA



Frame size AB

1

Applications

The MICROMASTER 410 inverter is suitable for a variety of variable-speed drive applications.

It is especially suitable for use with pumps and fans, as a drive in various sectors, e.g. food, textile and packaging industries, as well as for conveyor systems, factory gate and garage door drives, and as a universal drive for moving billboards.

It is the ideal low-cost frequency inverter solution for the bottom performance range of the MICROMASTER family.

The inverter is especially characterized by its customer-oriented performance and ease of use.

Versions for connection to 230-V and 115-V single-phase networks enable it to be used all over the world.

Design

The MICROMASTER 410 has a compact design.

Heat sinks provide natural cooling for the inverter. A fan unit is not used.

The position of the connections has been selected as for conventional contactors.

The operator panel available as an option can be easily fitted without requiring any tools.

Main Characteristics

- Simple selection from minimum range of types (only few options)
- Compact design
- Natural cooling with heat sinks (no fan unit)
- Simple connection similar to conventional switching elements (e.g. contactors)
- Version with internal EMC filter Class B
- Fast, simple commissioning with input of only a few parameters (fast commissioning mode)
- Integral RS-485 communications interface
- Three programmable digital inputs, non-floating (the analog input can be used as a 4th digital input)
- One analog input (0 V to 10 V)
- One programmable relay output (30 V DC/5 A resistive; 250 V AC/2 A inductive)
- Low-noise motor operation resulting from high pulse frequency
- Integral protection for motor and inverter.

Options (Overview)

- Line commutating chokes
- Adapter for standardized mounting on DIN rails
- OP operator panel for parameterizing an inverter
- PC connection set
- PC commissioning tool.

International Standards

- The MICROMASTER 410 inverter complies with the requirements of the EU low-voltage guideline; filtered versions also comply with the EU EMC guideline
- The MICROMASTER 410 inverter has the **CE** marking
- $\text{\textcircled{R}}$ and $\text{\textcircled{C}}$ listed
- c-tick 

Note:

See Appendix for standards.

Mechanical Features

- Compact design
- Heat dissipation through self-ventilation (convection)
- Operating temperature -10 °C to +50 °C
- Easy cable connection, mains and motor connections are separated for optimum electromagnetic compatibility and clear connection
- Detachable, optional operator panels
- Screwless control terminals
- Side mounting possible, thus also usable with low cabinet depth.

Performance Features

- Latest IGBT technology
- Digital microprocessor control
- Linear V/f characteristic, with programmable voltage boosting
- Quadratic V/f characteristic
- Multipoint characteristic (programmable V/f characteristic)
- Flying restart
- Automatic restart facility following power failure or fault
- Programmable acceleration (0 s to 650 s) with ramp smoothing
- Fast current limit (FCL) for trip free operation
- Fast, repeatable digital input response time
- Fine speed adjustment using a high resolution 10-bit analog input
- One skip frequency
- Removable “Y” capacitor for use on IT mains supplies
- Serial RS-485 interface with USS protocol
- LED for status information
- Versions with internal EMC filter Class B.

Protection Features

- Overload current 1.5 x rated output current (i.e. 150 % overload capability) for 60 s, then 0.85 x rated output current for 240 s, cycle time 300 s
- Overvoltage/undervoltage protection
- Inverter overtemperature protection
- Earth fault protection
- Short circuit protection
- I^2t motor thermal protection
- Stall prevention.

MICROMASTER 410

Circuit Diagrams

General Circuit Diagram

1

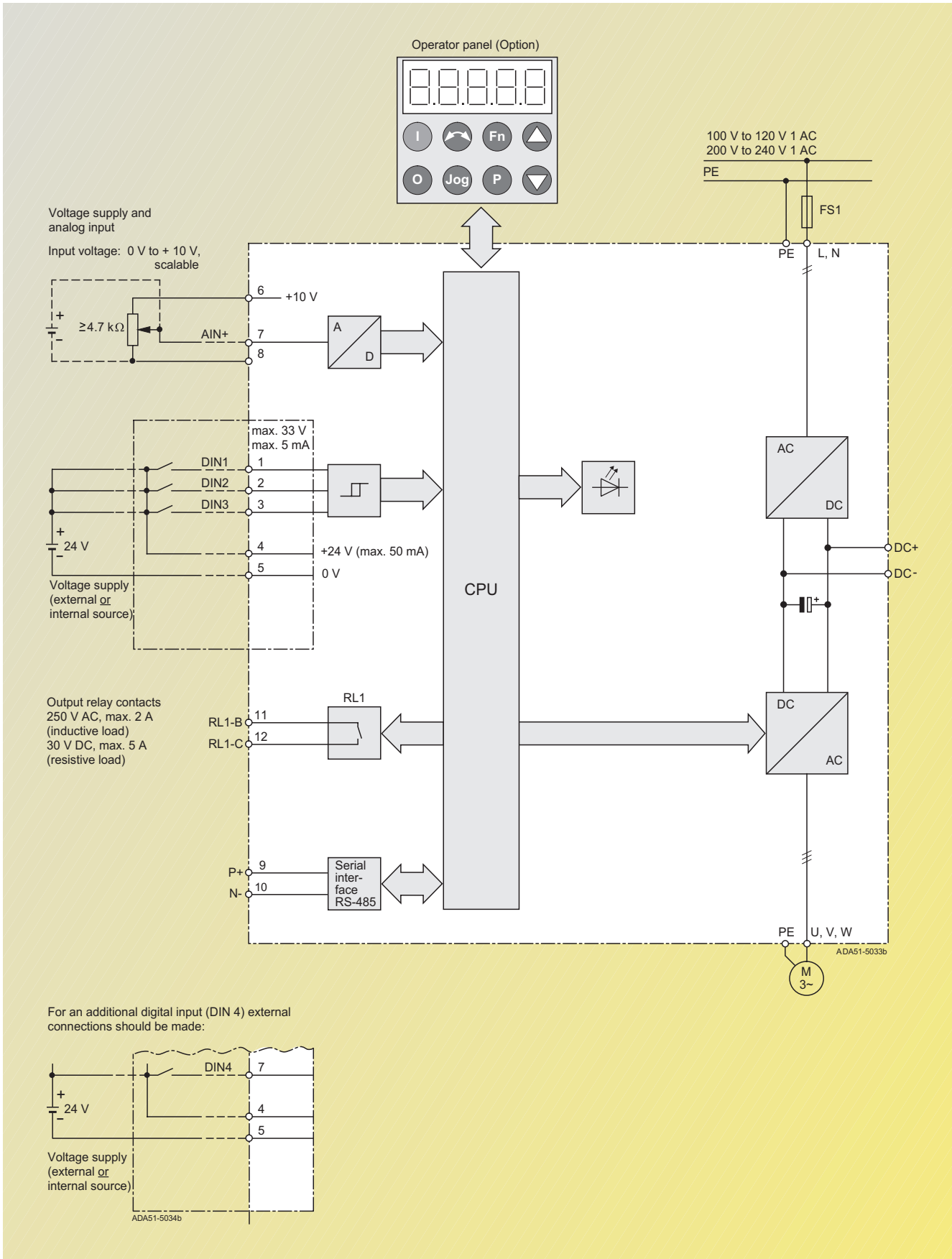

Terminal Connection Diagram

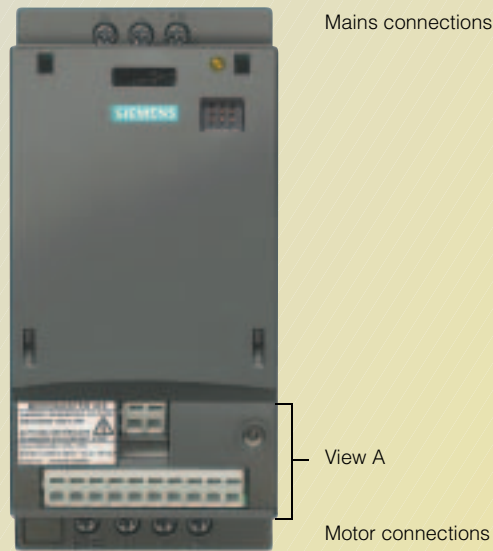

View A

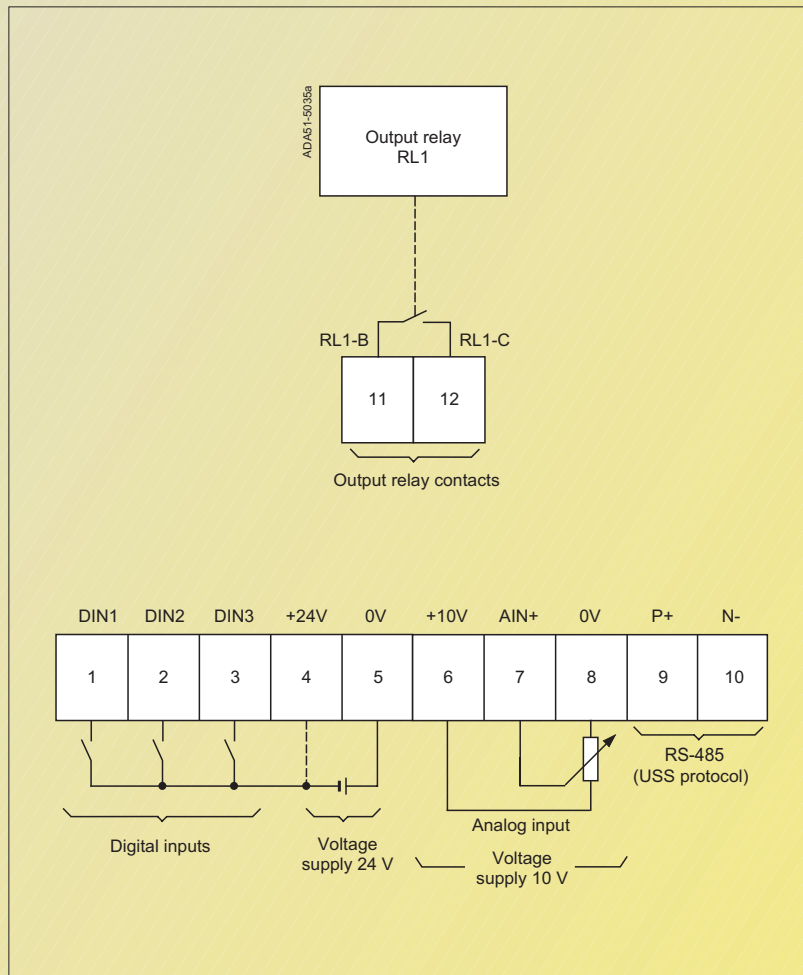

MICROMASTER 410

Technical Data

MICROMASTER 410 inverter

Input voltage and power ranges	200 V to 240 V 1 AC ± 10 % 100 V to 120 V 1 AC ± 10 %	0.12 to 0.75 kW 0.12 to 0.55 kW
Input frequency	47 to 63 Hz	
Output frequency	0 Hz to 650 Hz	
Power factor	≥ 0.95	
Inverter efficiency	96 % to 97 %	
Overload capability	Overload current 1.5 x rated output current (i.e. 150 % overload capability) for 60 s; then 0.85 x rated output current for 240 s, cycle time 300 s	
Inrush current	less than rated input current	
Control method	linear V/f, quadratic V/f, multipoint characteristic (programmable V/f)	
PWM frequency	8 kHz (standard) 2 kHz to 16 kHz (in 2 kHz steps)	
Fixed frequencies	3, programmable	
Skip frequency bands	1, programmable	
Setpoint resolution	10 bit analog 0.01 Hz serial	
Digital inputs	3 programmable digital inputs, non-floating; PNP, SIMATIC-compatible	
Analog inputs	1, for setpoint (0 V to 10 V, scaleable or for use as 4th digital input)	
Relay outputs	1, configurable 30 V DC/5 A (resistive), 250 V AC/2 A (inductive)	
Serial interfaces	RS-485, for operation with USS protocol	
Motor cable length	max. 30 m (shielded) max. 50 m (unshielded)	
Electromagnetic compatibility	Inverter available with internal EMC filter to EN 61 800-3 (defined limits to EN 55 011, Class B)	
Braking	DC Braking, Compound Braking	
Protection level	IP 20	
Temperature range	-10 °C to +50 °C	
Storage temperature	-40 °C to +70 °C	
Humidity	95 % (non-condensing)	
Operational altitudes	up to 1000 m above sea level without derating	
Protection features for	<ul style="list-style-type: none"> • under-voltage • over-voltage • overload • earth faults • short circuits • stall prevention • I²t motor thermal protection • motor over-temperature 	
Conformity with standards	Ⓜ, cⓂ, CE, c-tick	
CE marking	Conformity with EC low voltage directive 73/23/EC filtered versions also with electromagnetic compatibility directive 89/336/EC	
Dimensions and weights (without options)	Frame size (FS)	H x W x D (mm) Weight, approx. (kg)
	AA	150 x 69 x 118 0.8
	AB	150 x 69 x 138 1.0

Derating Data

Pulse frequency

Rated output kW	Rated output current in A for a pulse frequency of						
	4 kHz	6 kHz	8 kHz	10 kHz	12 kHz	14 kHz	16 kHz
0.12	0.9	0.9	0.9	0.8	0.7	0.6	0.5
0.25	1.7	1.7	1.7	1.5	1.3	1.1	0.9
0.37	2.3	2.3	2.3	2.0	1.7	1.5	1.3
0.55	3.2	3.2	3.2	2.9	2.6	2.3	2.0
0.55, 115 V (at 50 °C)	3.0	3.0	2.7	2.5	2.2	2.0	1.7
0.55, 115 V (at 40 °C)	3.2	3.2	3.2	2.9	2.6	2.3	2.0
0.75 (at 50 °C)	3.9	3.9	3.6	3.2	2.9	2.6	2.3
0.75 (at 40 °C)	4.2	4.2	4.2	3.8	3.4	3.0	2.7

The current data apply to an ambient temperature of 50 °C unless specified otherwise.

Derating Data (continued)

Installation height above sea level

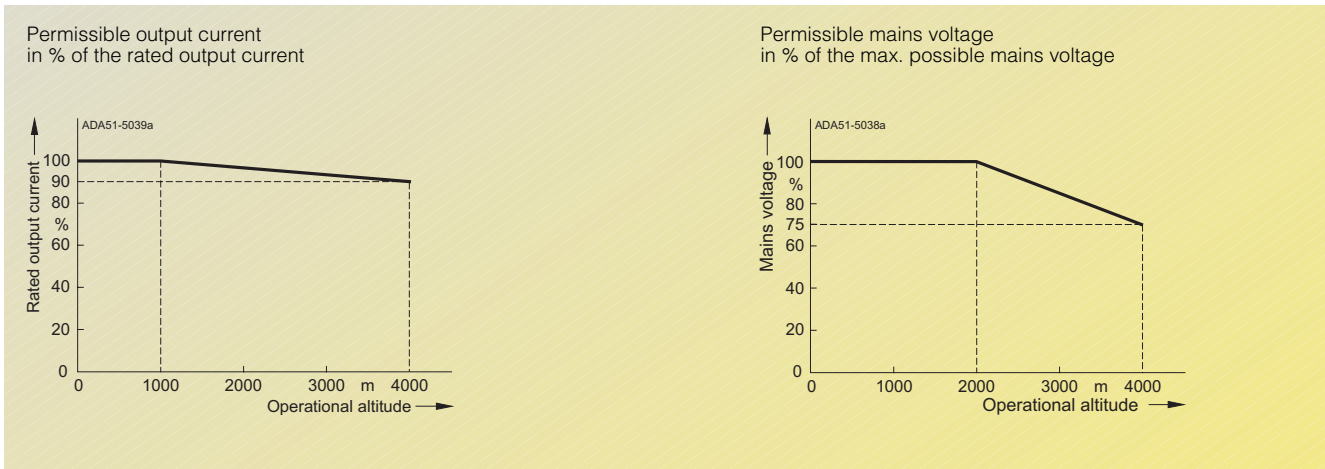

Selection and Ordering Data

MICROMASTER 410 Inverter

Rated output		Rated input current ¹⁾		Rated output current	Frame size	Order No.	
kW	hp	A	A	A	(FS)	MICROMASTER 410 without filter	MICROMASTER 410 with internal filter Class B
Mains operating voltage 100 V to 120 V 1 AC, output voltage 200 V to 240 V 3 AC							
0.12	0.16	4.6	0.9	AA		6SE6410-2UA11-2AA0	–
0.25	0.33	7.5	1.7	AA		6SE6410-2UA12-5AA0	–
0.37	0.50	10.1	2.3	AA		6SE6410-2UA13-7AA0	–
0.55	0.75	13.4	2.7 (3.2 at 40 °C)	AB		6SE6410-2UA15-5BA0	–
Mains operating voltage 200 V to 240 V 1 AC, output voltage 200 V to 240 V 3 AC							
0.12	0.16	1.5	0.9	AA		6SE6410-2UB11-2AA0	6SE6410-2BB11-2AA0
0.25	0.33	3.0	1.7	AA		6SE6410-2UB12-5AA0	6SE6410-2BB12-5AA0
0.37	0.50	4.4	2.3	AA		6SE6410-2UB13-7AA0	6SE6410-2BB13-7AA0
0.55	0.75	5.8	3.2	AB		6SE6410-2UB15-5BA0	6SE6410-2BB15-5BA0
0.75	1.0	7.8	3.6 (4.2 at 40 °C)	AB		6SE6410-2UB17-5BA0	6SE6410-2BB17-5BA0

The current data apply to an ambient temperature of 50 °C unless specified otherwise.



See Appendix for note on ordering.

All MICROMASTER 410 inverters are supplied without an operator panel (OP). An OP or other options have to be ordered additionally (see page 1/9).

Motors for MICROMASTER 410

Catalog M 11 contains selection and ordering data for motors which are particularly suitable for operation with the MICROMASTER 410 inverters (see Appendix for overview).

1) The values apply to rated mains voltages of 115 V or 230 V.

Options

Variant Dependent Options

EMC filter, Class B

Variants with **internal** EMC filter Class B are available for inverters with a mains operating voltage of 230 V 1 AC.

- The requirements are fulfilled using shielded cables with a max. length of 5 m, or 10 m with a low-capacitance motor cable (core/core < 75 pF/m, core/shield < 150 pF/m). The limits comply with EN 55 011 Class B.

An inverter with internal filter can be used with a 30-mA residual current operated circuit-breaker, and is only suitable for hardwired installation.

A non-filtered inverter together with the optional filter "Filter Class B with low leakage currents" has a leakage current ≤ 3.5 mA (shielded motor cable up to 5 m).

Line commutating choke

Line commutating chokes are used to smooth voltage peaks or to bridge commutating dips.

In addition, line commutating chokes reduce the effects of harmonics on the inverter and the power supply.

If the ratio of inverter rated power to network short-circuit power is less than 1 %, a line commutating choke must be used in order to reduce the current peaks.

The line commutating chokes are designed as footprint chokes and are fitted between the inverter and the mounting plate.

In line with the EN 61 000-3-2 regulations "Limits for harmonic currents with device input current ≤ 16 A per phase", there are special aspects for drives with 250 W to 550 W and 230-V single-phase supplies which can be used in non-industrial applications (1st environment).

For devices with 250 W and 370 W it is necessary either to fit the recommended input chokes or to apply to the power utility company for authorization to connect the devices to the public power supply.

No limits are currently defined in the EN 61 000-3-2 standard for professionally used devices with a connected load > 1 kW. This means that the inverters with an output power ≥ 0.75 kW comply with the EN 61 000-3-2 standard.

Variant Independent Options

Operator Panel (OP)

With the OP, individual parameter settings can be made.

Values and units are shown on a 5-digit display.

An OP can be used for several inverters. It is directly plugged into the inverter.



Inverter with Operator Panel (OP)

Connection set for PC to inverter

For controlling and commissioning an inverter directly from a PC if the appropriate software has been installed (e.g. STARTER).

The connection set includes an RS-485/RS-232 interface converter with a 9-pin Sub-D connector.

Commissioning tools

- **STARTER**
Starter is graphic start-up software for guided commissioning for MICROMASTER 410/420/430/440 frequency inverters under Windows NT/2000. Parameter lists can be read out, altered, stored, entered and printed.
- **DriveMonitor**
DriveMonitor is start-up software for list-oriented programming of frequency inverters under Windows 95/98/NT/2000.

Ordering Data for Variant Dependent Options

The options listed here (filters, chokes, fuses and circuit breakers) are inverter specific.

The inverter and the associated options have the same voltage ratings.

All variant dependent options and the operator panel are certified to [®], except fuses. The fuses of type 3NA3 are recommended for Europe.

Use in America requires [®]-listed fuses such as e.g. the Class NON range from Bussmann.

Mains operating voltage	Rated output kW	Inverter without filter	Order No. of the options			
			Filter Class B with low leakage currents	Line commutating choke	Fuse (see Catalog NS K)	Circuit-breaker (see Catalog NS K)
100 V to 120 V 1 AC	0.12	6SE6410-2UA11-2AA0	–	6SE6400-3CC01-0AB0	3NA3803	3RV1021-1GA10
	0.25	6SE6410-2UA12-5AA0	–			3RV1021-1JA10
	0.37	6SE6410-2UA13-7AA0 *)	–	6SE6400-3CC02-6BB0	3NA3805	3RV1021-1KA10
	0.55	6SE6410-2UA15-5BA0 *)	–		3NA3807	3RV1021-4AA10
200 V to 240 V 1 AC	0.12	6SE6410-2UB11-2AA0	6SE6400-2FL01-0AB0	6SE6400-3CC00-4AB0	3NA3803	3RV1021-1BA10
	0.25	6SE6410-2UB12-5AA0				3RV1021-1EA10
	0.37	6SE6410-2UB13-7AA0		6SE6400-3CC01-0AB0		3RV1021-1FA10
	0.55	6SE6410-2UB15-5BA0				3RV1021-1HA10
	0.75	6SE6410-2UB17-5BA0			3NA3805	3RV1021-1JA10
200 V to 240 V 1 AC	Inverter with internal filter Class B					
	0.12	6SE6410-2BB11-2AA0	–	6SE6400-3CC00-4AB0	3NA3803	3RV1021-1BA10
	0.25	6SE6410-2BB12-5AA0	–			3RV1021-1EA10
	0.37	6SE6410-2BB13-7AA0	–	6SE6400-3CC01-0AB0		3RV1021-1FA10
	0.55	6SE6410-2BB15-5BA0	–			3RV1021-1HA10
0.75	6SE6410-2BB17-5BA0	–		3NA3805	3RV1021-1JA10	

*) With these inverters, the choke cannot be mounted in the substructure; it must be mounted upright.

Ordering Data for Variant Independent Options

The options listed here are suitable for all MICROMASTER 410 Inverters.

Options	Order No.
Operator Panel (OP)	6SE6400-0SP00-0AA0
Connection set for PC to inverter	6SE6400-0PL00-0AA0
Adapter for mounting on DIN rail	6SE6400-0DR00-0AA0
Start-up tools STARTER and DriveMonitor, as well as multilanguage documentation on CD-ROM	6SE6400-5EA00-1AG0

Documentation

Type of documentation	Language	Order No.
Operating instructions ¹⁾ (paper version)	German	6SE6400-5EA00-0AP0
	English	6SE6400-5EA00-0BP0
	French	6SE6400-5EA00-0DP0
	Italian	6SE6400-5EA00-0CP0
	Spanish	6SE6400-5EA00-0EP0
Parameter list ¹⁾ (paper version)	German	6SE6400-5EB00-0AP0
	English	6SE6400-5EB00-0BP0
	French	6SE6400-5EB00-0DP0
	Italian	6SE6400-5EB00-0CP0
	Spanish	6SE6400-5EB00-0EP0
Getting Started Guide ¹⁾ (paper version), included with every inverter	Multilanguage	–

1) Available on Internet at <http://www.siemens.com/micromaster>.

MICROMASTER 410

Dimension Drawings

MICROMASTER 410 Inverter

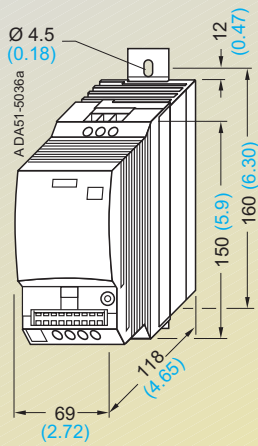

Inverter frame size AA

6SE6410-2...11-2AA0
 6SE6410-2...12-5AA0
 6SE6410-2...13-7AA0

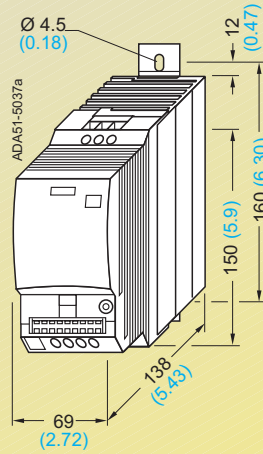

Inverter frame size AB

6SE6410-2...15-5BA0
 6SE6410-2...17-5BA0

All dimensions in mm (values in brackets are in inches)

1

Line commutating chokes

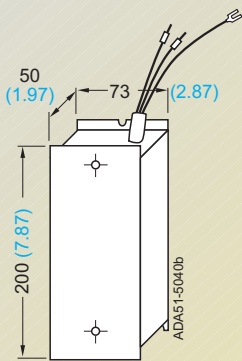

Footprint chokes

6SE6400-3CC00-4AB0
 6SE6400-3CC01-0AB0

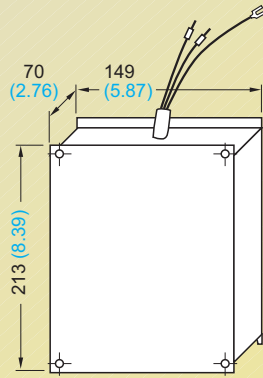

Chokes for upright mounting

6SE6400-3CC02-6BB0

All dimensions in mm (values in brackets are in inches)

Inverter

MICROMASTER 420



- 2/2 Description
- 2/4 Circuit Diagrams
- 2/6 Technical Data
- 2/8 Selection and Ordering Data
- 2/9 Options
- 2/16 Dimension Drawings

2



Description



2

Applications

The MICROMASTER 420 inverter is suitable for a variety of variable-speed drive applications. It is especially suitable for applications for pumps, fans and conveyor systems.

It is especially characterized by its customer-oriented performance and ease of use. Its large supply-voltage range enables it to be used all over the world.

Design

The MICROMASTER 420 has a modular design. The operator panels and communications modules can be easily exchanged without requiring any tools.

Main Characteristics

- Simple commissioning
- Modular construction allows maximum configuration flexibility
- Three fully programmable isolated digital inputs
- One scalable analog input (0 V to 10 V) can also be used as a 4th digital input
- One programmable analog output (0 mA to 20 mA)
- One fully programmable relay output (30 V DC/5 A, resistive 250 V AC/2 A, inductive)
- Silent motor operation is selectable when using high switching frequencies, adjustable (observe derating if necessary)
- Complete inverter and motor protection.

Options (Overview)

- EMC filters Class A/B
- Line commutating chokes
- Output chokes
- Gland plates
- BOP basic operator panel for parameterizing an inverter
- AOP advanced operator panel with plain-text and multilingual display
- Communications modules
 - PROFIBUS
 - DeviceNet
- PC connection kits
- Assembly kits for mounting the operator panels in the control cabinet doors
- PC commissioning tools, running under Windows 95/98 and NT/2000.

International Standards

- The MICROMASTER 420 inverter complies with the requirements of the EU low-voltage guideline; filtered versions also comply with the EU EMC guideline
- The MICROMASTER 420 inverter has the **CE** marking
- ® and c® listed
- c-tick 

Note:

See Appendix for standards.

Mechanical Features

- Modular design
- Operating temperature: -10 °C to +50 °C
- Compact housing as a result of high power density
- Easy cable connection, mains and motor connections are separated for optimum electromagnetic compatibility
- Detachable operator panels
- Screwless control terminals.

Performance Features

- Latest IGBT technology
- Digital microprocessor control
- Flux current control (FCC) for improved dynamic response and optimized motor control
- Linear V/f characteristic
- Quadratic V/f characteristic
- Multipoint characteristic (programmable V/f characteristic)
- Flying restart
- Slip compensation
- Automatic restart facility following power failure or fault
- PI feedback for simple process control.

Protection Features

- Overload current 1.5 x rated output current (i.e. 150 % overload capability) for 60 s, cycle time 300 s
- Overvoltage/undervoltage protection
- Inverter overtemperature protection
- Motor protection using PTC via digital input (possible with supplementary circuit)
- Earth fault protection
- Short circuit protection
- I^2t motor thermal protection
- Locked motor protection
- Stall prevention
- Parameter interlock.

MICROMASTER 420

Circuit Diagram

General Circuit Diagram

2

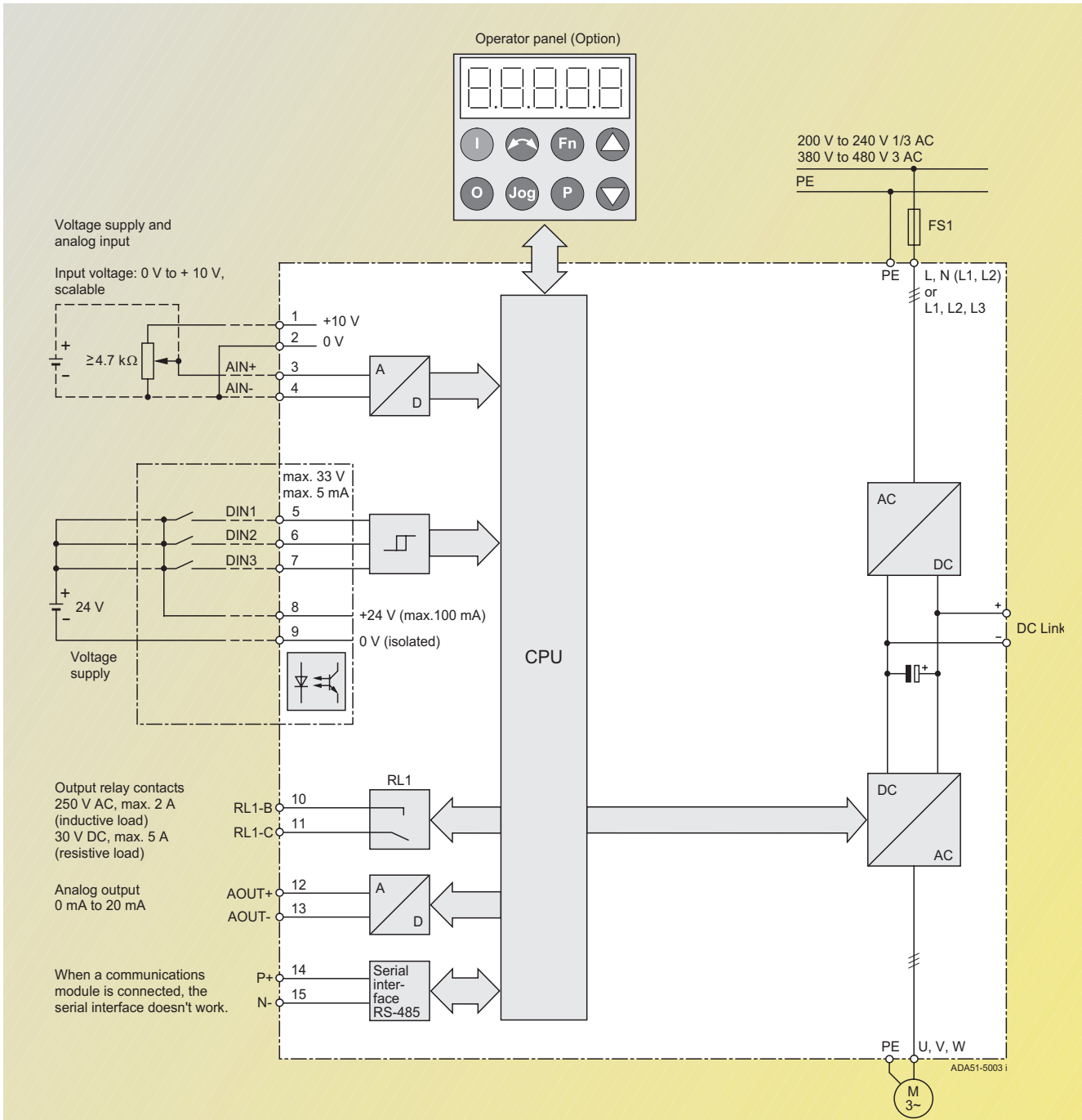

For an additional digital input (DIN4) external connections should be made:

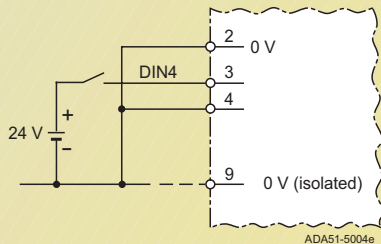

Terminal Connection Diagram

Example frame size A

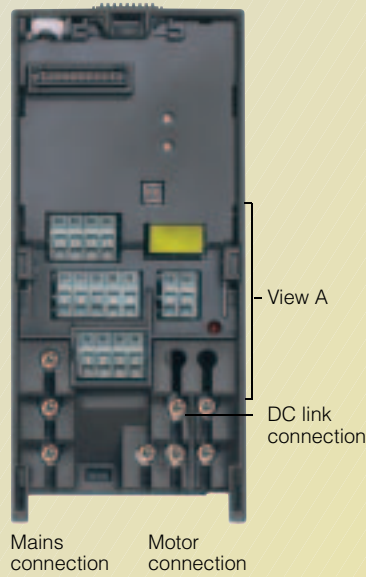

View A

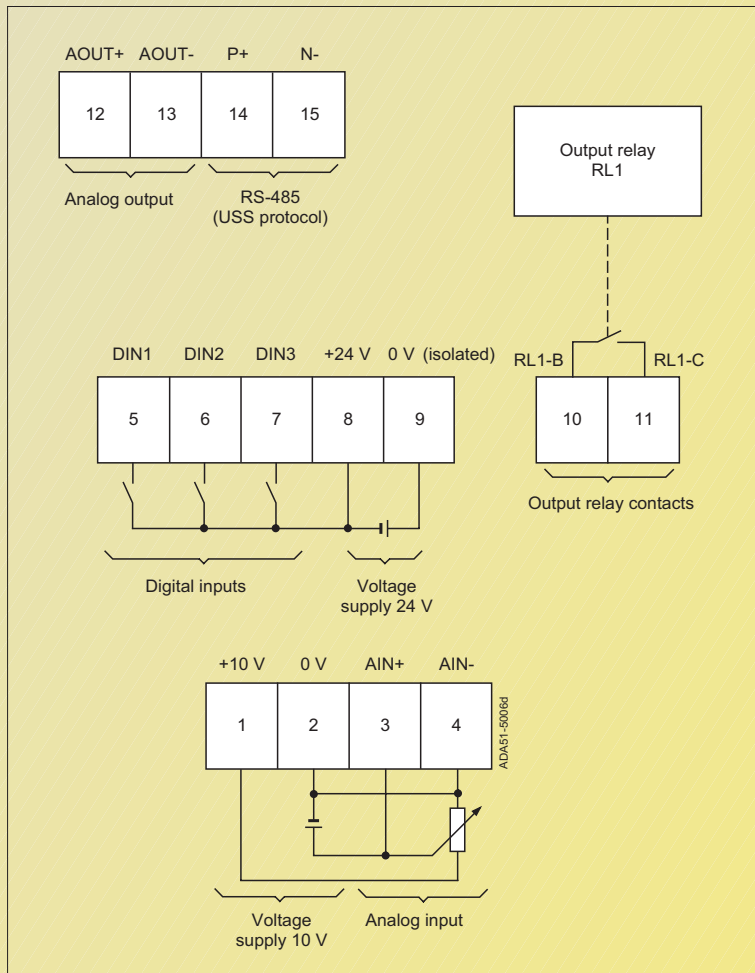

MICROMASTER 420

Technical Data

MICROMASTER 420 inverter

Input voltage and power ranges	200 V to 240 V 1 AC ± 10% 200 V to 240 V 3 AC ± 10% 380 V to 480 V 3 AC ± 10%	0.12 kW to 3 kW 0.12 kW to 5.5 kW 0.37 kW to 11 kW
Input frequency	47 Hz to 63 Hz	
Output frequency	0 Hz to 650 Hz	
Power factor	≥ 0.95	
Inverter efficiency	96% to 97%	
Overload capability	Overload current 1.5 x rated output current (i.e. 150 % overload capability) for 60 s, cycle time 300 s	
Inrush current	less than rated input current	
Control method	linear V/f; quadratic V/f; multipoint characteristic (programmable V/f); flux current control (FCC)	
PWM frequency	16 kHz (standard with 230 V 1/3 AC) 4 kHz (standard with 400 V 3 AC) 2 kHz to 16 kHz (in 2 kHz steps)	
Fixed frequencies	7, programmable	
Skip frequency bands	4, programmable	
Setpoint resolution	0.01 Hz digital 0.01 Hz serial 10 bit analog	
Digital inputs	3 fully programmable isolated digital inputs; switchable PNP/NPN	
Analog input	1 for setpoint or PI controller (0 to 10 V, scalable or for use as 4th digital input)	
Relay output	1, configurable 30 V DC/5 A (resistive), 250 V AC/2 A (inductive)	
Analog output	1, configurable (0 mA to 20 mA)	
Serial interfaces	RS-485, optional RS-232	
Motor cable length	without output choke with output choke	max. 50 m (shielded) max. 100 m (unshielded) max. 200 m (shielded) max. 300 m (unshielded)
Electromagnetic compatibility	Inverter available with internal EMC filter Class A; available as options are EMC filters to EN 55 011, Class A or Class B	
Braking	DC Braking, Compound Braking	
Protection level	IP 20	
Temperature range	-10 °C to +50 °C	
Storage temperature	-40 °C to +70 °C	
Humidity	95% (non-condensing)	
Operational altitudes	up to 1000 m above sea level without derating	
Protection features for	<ul style="list-style-type: none"> • under-voltage • over-voltage • overload • earth faults • short circuits • stall prevention • locked motor • motor over-temperature • inverter over-temperature • parameter PIN protection 	
Conformity with standards	Ⓜ, cⓂ, CE, c-tick	
CE marking	Conformity with EC low voltage directive 73/23/EC; filtered versions also with electromagnetic compatibility directive 89/336/EC	
Dimensions and weights (without options)	Frame size (FS)	H x W x D (mm) Weight, approx. (kg)
	A	173 x 73 x 149 1.0
	B	202 x 149 x 172 3.3
	C	245 x 185 x 195 5.0

2

Derating Data

Pulse frequency

Rated output (for 400 V 3 AC) kW	Rated output current in A for a pulse frequency of						
	4 kHz	6 kHz	8 kHz	10 kHz	12 kHz	14 kHz	16 kHz
0.37	1.2	1.2	1.2	1.2	1.2	1.2	1.1
0.55	1.6	1.6	1.6	1.6	1.6	1.6	1.1
0.75	2.1	2.1	2.1	2.1	1.6	1.6	1.1
1.1	3.0	3.0	2.7	2.7	1.6	1.6	1.1
1.5	4.0	4.0	2.7	2.7	1.6	1.6	1.1
2.2	5.9	5.9	5.1	5.1	3.6	3.6	2.6
3.0	7.7	7.7	5.1	5.1	3.6	3.6	2.6
4.0	10.2	10.2	6.7	6.7	4.8	4.8	3.6
5.5	13.2	13.2	13.2	13.2	9.6	9.6	7.5
7.5	18.4	18.4	13.2	13.2	9.6	9.6	7.5
11	26.0	26.0	17.9	17.9	13.5	13.5	10.4

Operating temperature

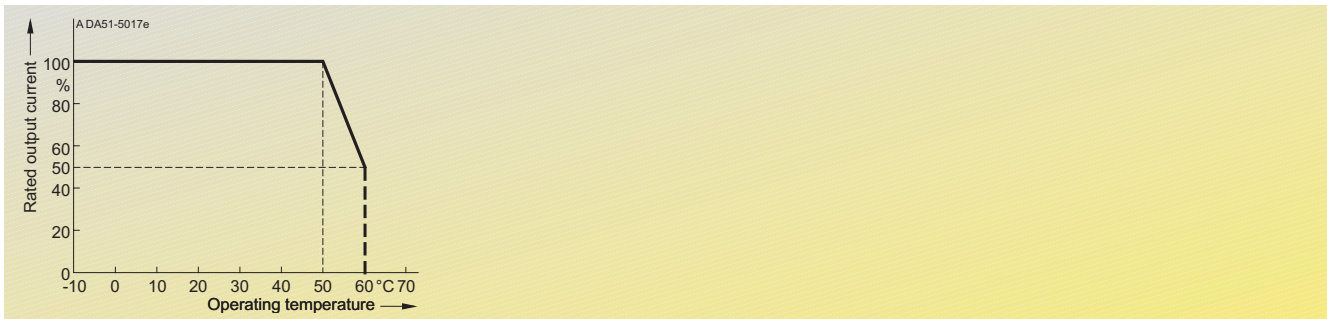

Installation height above sea level

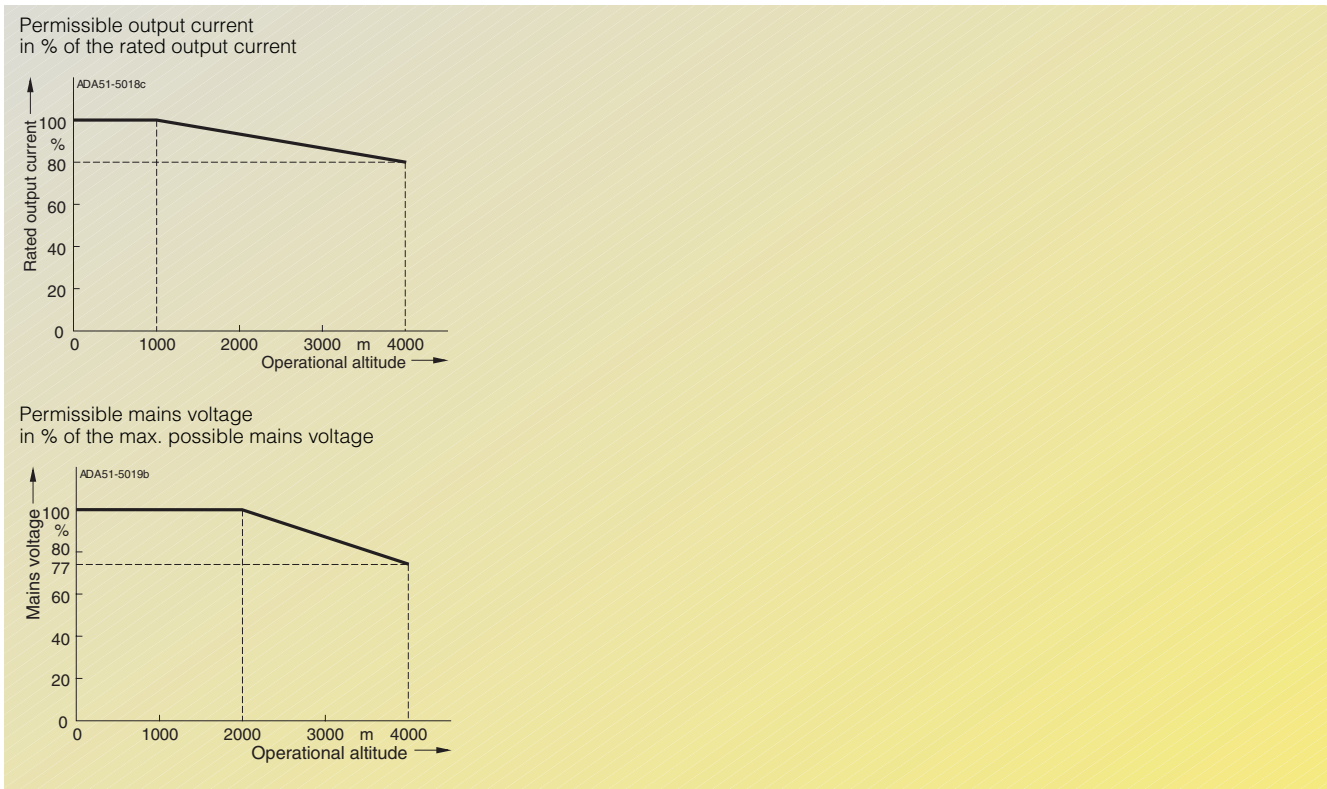

MICROMASTER 420

Selection and Ordering Data

MICROMASTER 420 Inverter

Rated output		Rated input current ¹⁾	Rated output current	Frame size	Order No.	
kW	hp	A	A	(FS)	MICROMASTER 420 without filter	MICROMASTER 420 with Class A filter ²⁾

Mains operating voltage 200 V to 240 V 1 AC

0.12	0.16	1.4	0.9	A	6SE6420-2UC11-2AA0	6SE6420-2AB11-2AA0
0.25	0.33	2.7	1.7	A	6SE6420-2UC12-5AA0	6SE6420-2AB12-5AA0
0.37	0.50	3.7	2.3	A	6SE6420-2UC13-7AA0	6SE6420-2AB13-7AA0
0.55	0.75	5.0	3.0	A	6SE6420-2UC15-5AA0	6SE6420-2AB15-5AA0
0.75	1.0	6.6	3.9	A	6SE6420-2UC17-5AA0	6SE6420-2AB17-5AA0
1.1	1.5	9.6	5.5	B	6SE6420-2UC21-1BA0	6SE6420-2AB21-1BA0
1.5	2.0	13.0	7.4	B	6SE6420-2UC21-5BA0	6SE6420-2AB21-5BA0
2.2	3.0	17.6	10.4	B	6SE6420-2UC22-2BA0	6SE6420-2AB22-2BA0
3.0	4.0	23.7	13.6	C	6SE6420-2UC23-0CA0	6SE6420-2AB23-0CA0

Mains operating voltage 200 V to 240 V 3 AC

0.12	0.16	0.6	0.9	A	6SE6420-2UC11-2AA0	–
0.25	0.33	1.1	1.7	A	6SE6420-2UC12-5AA0	–
0.37	0.50	1.6	2.3	A	6SE6420-2UC13-7AA0	–
0.55	0.75	2.1	3.0	A	6SE6420-2UC15-5AA0	–
0.75	1.0	2.9	3.9	A	6SE6420-2UC17-5AA0	–
1.1	1.5	4.1	5.5	B	6SE6420-2UC21-1BA0	–
1.5	2.0	5.6	7.4	B	6SE6420-2UC21-5BA0	–
2.2	3.0	7.6	10.4	B	6SE6420-2UC22-2BA0	–
3.0	4.0	10.5	13.6	C	6SE6420-2UC23-0CA0	6SE6420-2AC23-0CA0
4.0	5.0	13.1	17.5	C	6SE6420-2UC24-0CA0	6SE6420-2AC24-0CA0
5.5	7.5	17.5	22.0	C	6SE6420-2UC25-5CA0	6SE6420-2AC25-5CA0

Mains operating voltage 380 V to 480 V 3 AC

0.37	0.50	1.1	1.2	A	6SE6420-2UD13-7AA0	–
0.55	0.75	1.4	1.6	A	6SE6420-2UD15-5AA0	–
0.75	1.0	1.9	2.1	A	6SE6420-2UD17-5AA0	–
1.1	1.5	2.8	3.0	A	6SE6420-2UD21-1AA0	–
1.5	2.0	3.9	4.0	A	6SE6420-2UD21-5AA0	–
2.2	3.0	5.0	5.9	B	6SE6420-2UD22-2BA0	6SE6420-2AD22-2BA0
3.0	4.0	6.7	7.7	B	6SE6420-2UD23-0BA0	6SE6420-2AD23-0BA0
4.0	5.0	8.5	10.2	B	6SE6420-2UD24-0BA0	6SE6420-2AD24-0BA0
5.5	7.5	11.6	13.2	C	6SE6420-2UD25-5CA0	6SE6420-2AD25-5CA0
7.5	10.0	15.4	19.0	C	6SE6420-2UD27-5CA0	6SE6420-2AD27-5CA0
11	15.0	22.5	26.0	C	6SE6420-2UD31-1CA0	6SE6420-2AD31-1CA0



See Appendix for note on ordering.

All MICROMASTER 420 are supplied with a Status Display Panel SDP. A Basic Operator Panel BOP, Advanced Operator Panel AOP or other options have to be ordered additionally (see pages 2/11 to 2/15).

Motors for MICROMASTER 420

Catalog M 11 contains selection and ordering data for motors which are particularly suitable for operation with the MICROMASTER 420 inverters (see Appendix for overview).

1) The values apply to rated mains voltages of 240 V or 400 V.

2) Use of MICROMASTER inverters with internal filter is not permissible on non-grounded (IT) mains supplies.

Variant Dependent Options**EMC filter, Class A**

Filter for inverters without an internal filter, for

- 200 V to 240 V 3 AC, frame sizes A and B
- 380 V to 480 V 3 AC, frame size A.

All other inverters can be supplied with an internal Class A filter.

The requirements are fulfilled using shielded cables with a max. length of 25 m.

EMC filter, Class B

Filter for inverters without an internal filter, for

- 200 V to 240 V 3 AC, frame sizes A and B
- 380 V to 480 V 3 AC, frame size A.

With this filter, the inverter complies with the emission standard EN 55 011, Class B.

The requirements are fulfilled using shielded cables with a max. length of 25 m.

Additional EMC filter, Class B

Obtainable for inverters with an internal Class A EMC filter A.

With this filter, the inverter complies with the emission standard EN 55 011, Class B.

The requirements are fulfilled using shielded cables with a max. length of 25 m.

Class B filter with low leakage currents

EMC filter for 200 V to 240 V 1 AC inverters, frame sizes A and B, without an internal (Class A) EMC filter.

With this filter, the inverter complies with the emission standard EN 55 011, Class B. The leakage currents are reduced to < 3.5 mA.

The requirements are fulfilled using shielded cables with a max. length of 5 m.

Leakage currents:

The leakage currents of the inverters with/without filter (internal/external) may exceed 30 mA. Typical values in practice are between 10 mA and 50 mA. The exact values depend on the design, environment and cable lengths. Interference-free operation with residual current operated devices with a trigger value of 30 mA cannot be guaranteed. However, operation with residual current operated devices with a trigger value of 300 mA is possible. Please refer to the Instruction Manual for details.

Line commutating choke

Line commutating chokes are used to smooth voltage peaks or to bridge commutating dips. In addition, line commutating chokes reduce the effects of harmonics on the inverter and the power supply. If the line impedance is < 1%, a line commutating choke must be used in order to reduce the current peaks.

In line with the EN 61 000-3-2 regulations "Limits for harmonic currents with device input current ≤ 16 A per phase", there are special aspects for drives with 250 W to 550 W and 230-V single-phase supplies which can be used in non-industrial applications (1st environment).

For devices with 250 W and 370 W it is necessary either to fit the recommended input chokes or to apply to the power utility company for authorization to connect the devices to the public power supply.

No limits are currently defined in the EN 61 000-3-2 standard for professionally used devices with a connected load > 1 kW. This means that the inverters with an output power ≥ 0.75 kW comply with the EN 61 000-3-2 standard.

Output choke

Output chokes can be supplied for reducing the capacitive currents and dV/dt in the case of motor cables > 50 m (shielded) or > 100 m (unshielded).

Gland plate

The gland plate enables shielded connection of the power and control cables, ensuring optimum EMC performance. This ensures compliance with the NEMA 1 directive.

Options

Variant Independent Options

Basic Operator Panel (BOP)

With the BOP, individual parameter settings can be made. Values and units are shown on a 5-digit display.



Basic Operator Panel (BOP)

A BOP can be used for several inverters. It can be directly mounted on the inverter or in a control-cabinet door using a mounting kit.

Advanced Operator Panel (AOP)

The AOP enables parameter sets to be read out of the inverter or to be written into the inverter (upload/download). Different parameter sets can be stored in the AOP. It has a plain-text display with the possibility of switching between several languages.



Advanced Operator Panel (AOP)

Up to 30 inverters can be controlled from an AOP via USS protocol. It can be directly plugged into the inverter or built into the control-cabinet door using a mounting kit.

PROFIBUS module

For a complete PROFIBUS connection with up to 12 Mbaud. Remote control of the inverter is possible with the PROFIBUS module. Remote control and operation at the inverter can be combined using an operator panel – plugged onto the PROFIBUS module. The latter can be supplied by an external 24 V DC power supply and is thus also active when the inverter is disconnected from the mains.

Connection by means of a 9-pin SUB-D connector (available as an accessory).

DeviceNet module

For networking the inverters to the DeviceNet fieldbus system widely used on the American market. A max. transmission rate of 500 kbaud is possible. Remote control of the module is possible via the DeviceNet module. Remote control and operation on the inverter can be combined using an operator panel connected to the DeviceNet module.

The connection to the DeviceNet bus system is made using a 5-pin connector with terminal strip.

Connection set for PC to inverter

For controlling an inverter directly from a PC if the appropriate software has been installed (e.g. STARTER) in the PC. Isolated RS-232 adapter board for reliable point-to-point connection to a PC. Includes a Sub-D connector and an RS-232 standard cable (3 m).

Connection set for PC to AOP

For connecting a PC to an AOP. Offline programming of inverters and archiving of parameter sets possible. Includes a desktop attachment kit for an AOP, an RS-232 standard cable (3 m) with Sub-D connectors and a universal power supply unit.

Operator panel door mounting kit for single inverter

For mounting an operator panel in a control cabinet door. Degree of protection is IP 56. Contains a cable adapter board with screwless terminals for use with the user's own cables.

AOP door mounting kit for multiple inverter (USS)

For mounting an AOP in a control cabinet door. Degree of protection IP 56. The AOP can communicate with several inverters by means of the RS-485 USS protocol. The 4-pin connecting cable from the AOP to the RS-485 terminals of the inverter and to the 24 V user terminal strip is not included.

Commissioning tools

- **STARTER**
Starter is start-up software for guided commissioning for MICROMASTER 410/420/430/440 frequency inverters under Windows NT/2000. Parameter lists can be read out, altered, stored, entered and printed.
- **DriveMonitor**
DriveMonitor is start-up software for list-oriented programming of frequency inverters under Windows 95/98/NT/2000.

Both programs are included on the Docu CD which is provided with every inverter.

Ordering Data for Variant Dependent Options

The options listed here (filters, chokes, gland plates, fuses and circuit breakers) are inverter specific.

The inverter and the associated options have the same voltage ratings.

All options are certified to [®], except fuses. The fuses of type 3NA3 are recommended for Europe.

Use in America requires [®]-listed fuses such as e.g. the Class NON range from Bussmann.

Mains operating voltage	Rated output kW	Inverter without filter	Order No. of the options		
			EMC filter Class A	EMC filter Class B	Supplementary EMC filter Class B
200 V to 240 V 1 AC	0.12	6SE6420-2UC11-2AA0	–	–	–
	0.25	6SE6420-2UC12-5AA0	–	–	–
	0.37	6SE6420-2UC13-7AA0	–	–	–
	0.55	6SE6420-2UC15-5AA0	–	–	–
	0.75	6SE6420-2UC17-5AA0	–	–	–
	1.1	6SE6420-2UC21-1BA0	–	–	–
	1.5	6SE6420-2UC21-5BA0	–	–	–
	2.2	6SE6420-2UC22-2BA0	–	–	–
	3.0	6SE6420-2UC23-0CA0	–	–	–
	200 V to 240 V 3 AC	0.12	6SE6420-2UC11-2AA0	6SE6400-2FA00-6AD0	6SE6400-2FB00-6AD0
0.25		6SE6420-2UC12-5AA0	–	–	–
0.37		6SE6420-2UC13-7AA0	–	–	–
0.55		6SE6420-2UC15-5AA0	–	–	–
0.75		6SE6420-2UC17-5AA0	–	–	–
1.1		6SE6420-2UC21-1BA0	6SE6400-2FA01-4BC0	6SE6400-2FB01-4BC0	–
1.5		6SE6420-2UC21-5BA0	–	–	–
2.2		6SE6420-2UC22-2BA0	–	–	–
3.0		6SE6420-2UC23-0CA0	–	–	–
4.0		6SE6420-2UC24-0CA0	–	–	–
380 V to 480 V 3 AC	0.37	6SE6420-2UD13-7AA0	6SE6400-2FA00-6AD0	6SE6400-2FB00-6AD0	–
	0.55	6SE6420-2UD15-5AA0	–	–	–
	0.75	6SE6420-2UD17-5AA0	–	–	–
	1.1	6SE6420-2UD21-1AA0	–	–	–
	1.5	6SE6420-2UD21-5AA0	–	–	–
	2.2	6SE6420-2UD22-2BA0	–	–	–
	3.0	6SE6420-2UD23-0BA0	–	–	–
	4.0	6SE6420-2UD24-0BA0	–	–	–
	5.5	6SE6420-2UD25-5CA0	–	–	–
	7.5	6SE6420-2UD27-5CA0	–	–	–
200 V to 240 V 1 AC		Inverter with internal filter Class A			
	0.12	6SE6420-2AB11-2AA0	–	–	6SE6400-2FS01-0AB0
	0.25	6SE6420-2AB12-5AA0	–	–	–
	0.37	6SE6420-2AB13-7AA0	–	–	–
	0.55	6SE6420-2AB15-5AA0	–	–	–
	0.75	6SE6420-2AB17-5AA0	–	–	–
	1.1	6SE6420-2AB21-1BA0	–	–	6SE6400-2FS02-6BB0
	1.5	6SE6420-2AB21-5BA0	–	–	–
	2.2	6SE6420-2AB22-2BA0	–	–	–
	3.0	6SE6420-2AB23-0CA0	–	–	6SE6400-2FS03-5CB0
200 V to 240 V 3 AC	3.0	6SE6420-2AC23-0CA0	–	–	6SE6400-2FS03-8CD0
	4.0	6SE6420-2AC24-0CA0	–	–	–
	5.5	6SE6420-2AC25-5CA0	–	–	–
380 V to 480 V 3 AC	2.2	6SE6420-2AD22-2BA0	–	–	6SE6400-2FS01-6BD0
	3.0	6SE6420-2AD23-0BA0	–	–	–
	4.0	6SE6420-2AD24-0BA0	–	–	–
	5.5	6SE6420-2AD25-5CA0	–	–	6SE6400-2FS03-8CD0
	7.5	6SE6420-2AD27-5CA0	–	–	–
	11	6SE6420-2AD31-1CA0	–	–	–

MICROMASTER 420

Options

Ordering Data for Variant Dependent Options (continued)

Mains operating voltage	Rated output kW	Inverter without filter	Order No. of the options		
			Low leakage Class B	Line commutating choke	Output choke
200 V to 240 V 1 AC	0.12	6SE6420-2UC11-2AA0	6SE6400-2FL01-0AB0	6SE6400-3CC00-4AB0	6SE6400-3TC00-4AD1
	0.25	6SE6420-2UC12-5AA0			
	0.37	6SE6420-2UC13-7AA0			
	0.55	6SE6420-2UC15-5AA0		6SE6400-3CC01-0AB0	
	0.75	6SE6420-2UC17-5AA0			
	1.1	6SE6420-2UC21-1BA0	6SE6400-2FL02-6BB0	6SE6400-3CC02-6BB0	6SE6400-3TC01-0BD0
	1.5	6SE6420-2UC21-5BA0			
	2.2	6SE6420-2UC22-2BA0			
3.0	6SE6420-2UC23-0CA0	–	6SE6400-3CC03-5CB0	6SE6400-3TC03-2CD0	
200 V to 240 V 3 AC	0.12	6SE6420-2UC11-2AA0	–	6SE6400-3CC00-3AC0	6SE6400-3TC00-4AD1
	0.25	6SE6420-2UC12-5AA0	–		
	0.37	6SE6420-2UC13-7AA0	–	6SE6400-3CC00-5AC0	
	0.55	6SE6420-2UC15-5AA0	–		
	0.75	6SE6420-2UC17-5AA0	–		
	1.1	6SE6420-2UC21-1BA0	–	6SE6400-3CC00-8BC0	6SE6400-3TC01-0BD0
	1.5	6SE6420-2UC21-5BA0	–	6SE6400-3CC01-4BD0	
	2.2	6SE6420-2UC22-2BA0	–		
	3.0	6SE6420-2UC23-0CA0	–	6SE6400-3CC01-7CC0	6SE6400-3TC03-2CD0
	4.0	6SE6420-2UC24-0CA0	–	6SE6400-3CC03-5CD0	
5.5	6SE6420-2UC25-5CA0	–			
380 V to 480 V 3 AC	0.37	6SE6420-2UD13-7AA0	–	6SE6400-3CC00-2AD0	6SE6400-3TC01-0BD0 (not suitable for footprint mounting)
	0.55	6SE6420-2UD15-5AA0	–		
	0.75	6SE6420-2UD17-5AA0	–	6SE6400-3CC00-4AD0	
	1.1	6SE6420-2UD21-1AA0	–		
	1.5	6SE6420-2UD21-5AA0	–	6SE6400-3CC00-6AD0	
	2.2	6SE6420-2UD22-2BA0	–	6SE6400-3CC01-0BD0	6SE6400-3TC01-0BD0
	3.0	6SE6420-2UD23-0BA0	–		
	4.0	6SE6420-2UD24-0BA0	–	6SE6400-3CC01-4BD0	
	5.5	6SE6420-2UD25-5CA0	–	6SE6400-3CC02-2CD0	6SE6400-3TC03-2CD0
	7.5	6SE6420-2UD27-5CA0	–		
11	6SE6420-2UD31-1CA0	–	6SE6400-3CC03-5CD0		
		Inverter with internal filter Class A			
200 V to 240 V 1 AC	0.12	6SE6420-2AB11-2AA0	–	6SE6400-3CC00-4AB0	6SE6400-3TC00-4AD1
	0.25	6SE6420-2AB12-5AA0	–		
	0.37	6SE6420-2AB13-7AA0	–	6SE6400-3CC01-0AB0	
	0.55	6SE6420-2AB15-5AA0	–		
	0.75	6SE6420-2AB17-5AA0	–		
	1.1	6SE6420-2AB21-1BA0	–	6SE6400-3CC02-6BB0	6SE6400-3TC01-0BD0
	1.5	6SE6420-2AB21-5BA0	–		
	2.2	6SE6420-2AB22-2BA0	–		
3.0	6SE6420-2AB23-0CA0	–	6SE6400-3CC03-5CB0	6SE6400-3TC03-2CD0	
200 V to 240 V 3 AC	3.0	6SE6420-2AC23-0CA0	–	6SE6400-3CC01-7CC0	6SE6400-3TC03-2CD0
	4.0	6SE6420-2AC24-0CA0	–	6SE6400-3CC03-5CD0	
	5.5	6SE6420-2AC25-5CA0	–		
380 V to 480 V 3 AC	2.2	6SE6420-2AD22-2BA0	–	6SE6400-3CC01-0BD0	6SE6400-3TC01-0BD0
	3.0	6SE6420-2AD23-0BA0	–		
	4.0	6SE6420-2AD24-0BA0	–	6SE6400-3CC01-4BD0	
	5.5	6SE6420-2AD25-5CA0	–	6SE6400-3CC02-2CD0	6SE6400-3TC03-2CD0
	7.5	6SE6420-2AD27-5CA0	–		
	11	6SE6420-2AD31-1CA0	–	6SE6400-3CC03-5CD0	

2

Ordering Data for Variant Dependent Options (continued)

Mains operating voltage	Rated output kW	Inverter without filter	Order No. of the options		
			Gland plate	Fuse (see Catalog NS K)	Circuit breaker (see Catalog NS K)
200 V to 240 V 1 AC	0.12	6SE6420-2UC11-2AA0	6SE6400-0GP00-0AA0	3NA3803	3RV1021-1CA10
	0.25	6SE6420-2UC12-5AA0			3RV1021-1FA10
	0.37	6SE6420-2UC13-7AA0			3RV1021-1HA10
	0.55	6SE6420-2UC15-5AA0			3RV1021-1JA10
	0.75	6SE6420-2UC17-5AA0		3NA3805	3RV1021-1KA10
	1.1	6SE6420-2UC21-1BA0	6SE6400-0GP00-0BA0	3NA3807	3RV1021-4BA10
	1.5	6SE6420-2UC21-5BA0			3RV1021-4DA10
	2.2	6SE6420-2UC22-2BA0		3NA3810	3RV1031-4EA10
	3.0	6SE6420-2UC23-0CA0	6SE6400-0GP00-0CA0	3NA3812	3RV1031-4GA10
200 V to 240 V 3 AC	0.12	6SE6420-2UC11-2AA0	6SE6400-0GP00-0AA0	3NA3803	3RV1021-0JA10
	0.25	6SE6420-2UC12-5AA0			3RV1021-1CA10
	0.37	6SE6420-2UC13-7AA0			3RV1021-1DA10
	0.55	6SE6420-2UC15-5AA0			3RV1021-1FA10
	0.75	6SE6420-2UC17-5AA0			3RV1021-1GA10
	1.1	6SE6420-2UC21-1BA0	6SE6400-0GP00-0BA0	3NA3805	3RV1021-1HA10
	1.5	6SE6420-2UC21-5BA0			3RV1021-1JA10
	2.2	6SE6420-2UC22-2BA0		3NA3807	3RV1021-4AA10
	3.0	6SE6420-2UC23-0CA0	6SE6400-0GP00-0CA0	3NA3810	3RV1021-4BA10
4.0	6SE6420-2UC24-0CA0	3NA3812		3RV1021-4DA10	
5.5	6SE6420-2UC25-5CA0		3NA3814	3RV1031-4FA10	
380 V to 480 V 3 AC	0.37	6SE6420-2UD13-7AA0	6SE6400-0GP00-0AA0	3NA3803	3RV1021-1CA10
	0.55	6SE6420-2UD15-5AA0			3RV1021-1DA10
	0.75	6SE6420-2UD17-5AA0			3RV1021-1EA10
	1.1	6SE6420-2UD21-1AA0			3RV1021-1GA10
	1.5	6SE6420-2UD21-5AA0			3RV1021-1HA10
	2.2	6SE6420-2UD22-2BA0	6SE6400-0GP00-0BA0	3NA3805	3RV1021-1JA10
	3.0	6SE6420-2UD23-0BA0			3RV1021-1KA10
	4.0	6SE6420-2UD24-0BA0		3NA3807	3RV1021-4AA10
	5.5	6SE6420-2UD25-5CA0	6SE6400-0GP00-0CA0		3RV1021-4CA10
7.5	6SE6420-2UD27-5CA0	3NA3810		3RV1031-4EA10	
11	6SE6420-2UD31-1CA0	3NA3814		3RV1031-4FA10	
		Inverter with internal filter Class A			
200 V to 240 V 1 AC	0.12	6SE6420-2AB11-2AA0	6SE6400-0GP00-0AA0	3NA3803	3RV1021-1CA10
	0.25	6SE6420-2AB12-5AA0			3RV1021-1FA10
	0.37	6SE6420-2AB13-7AA0			3RV1021-1HA10
	0.55	6SE6420-2AB15-5AA0			3RV1021-1JA10
	0.75	6SE6420-2AB17-5AA0		3NA3805	3RV1021-1KA10
	1.1	6SE6420-2AB21-1BA0	6SE6400-0GP00-0BA0	3NA3807	3RV1021-4BA10
	1.5	6SE6420-2AB21-5BA0			3RV1021-4DA10
	2.2	6SE6420-2AB22-2BA0		3NA3810	3RV1031-4EA10
	3.0	6SE6420-2AB23-0CA0	6SE6400-0GP00-0CA0	3NA3812	3RV1031-4GA10
200 V to 240 V 3 AC	3.0	6SE6420-2AC23-0CA0	6SE6400-0GP00-0CA0	3NA3810	3RV1021-4BA10
	4.0	6SE6420-2AC24-0CA0		3NA3812	3RV1021-4DA10
	5.5	6SE6420-2AC25-5CA0		3NA3814	3RV1031-4FA10
380 V to 480 V 3 AC	2.2	6SE6420-2AD22-2BA0	6SE6400-0GP00-0BA0	3NA3805	3RV1021-1JA10
	3.0	6SE6420-2AD23-0BA0			3RV1021-1KA10
	4.0	6SE6420-2AD24-0BA0			3NA3807
	5.5	6SE6420-2AD25-5CA0	6SE6400-0GP00-0CA0		3RV1021-4CA10
	7.5	6SE6420-2AD27-5CA0		3NA3810	3RV1031-4EA10
	11	6SE6420-2AD31-1CA0		3NA3814	3RV1031-4FA10

Options

Ordering Data for Variant Independent Options

The options listed here are suitable for all MICROMASTER 420 Inverters.

Options	Order No.
Basic Operator Panel (BOP)	6SE6400-0BP00-0AA0
Advanced Operator Panel (AOP)	6SE6400-0AP00-0AA1
PROFIBUS module	6SE6400-1PB00-0AA0
DeviceNet module	6SE6400-1DN00-0AA0
RS485/PROFIBUS bus connector	6GK1500-0FC00
Connection set for PC to inverter	6SE6400-1PC00-0AA0
Connection set for PC to AOP	6SE6400-0PA00-0AA0
Operator panel door mounting kit for single inverter	6SE6400-0PM00-0AA0
AOP-door mounting kit for multiple inverter (USS)	6SE6400-0MD00-0AA0

Technical data of the communications modules

PROFIBUS module
6SE6400-1PB00-0AA0



DeviceNet module
6SE6400-1DN00-0AA0



Size (height x width x depth)	161 mm x 73 mm x 46 mm	
Degree of protection	IP 20	
Degree of pollution	2 to IEC 60 664-1 (DIN VDE 0110/T1), no condensation permitted during operation	
Mechanical strength	to DIN IEC 60 068-2-6 (if module installed correctly)	
• Stationary	Deflection	0.15 mm in the frequency range of 10 Hz to 58 Hz
• Transport	Acceleration	19.6 m/s ² in the frequency range of 58 Hz to 500 Hz
	Deflection	3.5 mm in the frequency range of 5 Hz to 9 Hz
	Acceleration	9.8 m/s ² in the frequency range of 9 Hz to 500 Hz
Climatic category (during operation)	3K3 to DIN IEC 60 721-3-3	
Cooling method	Natural air cooling	
Permissible ambient or cooling agent temperature		
• in operation	-10 °C to +50 °C (14 °F to 122 °F)	
• during storage and transport	-25 °C to +70 °C (-13 °F to 158 °F)	
Relative humidity (permissible humidity rating)		
• in operation	≤ 85% (non-condensing)	
• during storage and transport	≤ 95%	
Electromagnetic compatibility	Emission Interference radiation	to EN 55 011 (1991) Class A to IEC 60 801-3 and EN 61 000-4-3
Supply voltage	6.5 V ± 5%, max. 300 mA, internal from inverter or 24 V ± 10%, max. 350 mA, external	6.5 V ± 5%, max. 300 mA internal from inverter and 24 V, max. 60 mA from DeviceNet bus
Output voltage	5 V ± 10%, max. 100 mA, galvanically isolated supply • for terminating the serial interface bus or • for supplying the OLP (Optical Link Plug)	-
Data transmission rate	max. 12 Mbaud	125, 250 and 500 kbaud

Documentation

Type of documentation	Language	Order No.
Docu-Pack , supplied with each inverter, containing CD-ROM ¹⁾ and Getting-Started Guide ²⁾ (paper version)	Multilanguage	6SE6400-5AB00-1AP0
Operating instructions ²⁾ (paper version)	German	6SE6400-5AA00-0AP0
	English	6SE6400-5AA00-0BP0
	French	6SE6400-5AA00-0DP0
	Italian	6SE6400-5AA00-0CP0
	Spanish	6SE6400-5AA00-0EP0
Parameter list ²⁾ (paper version)	German	6SE6400-5BA00-0AP0
	English	6SE6400-5BA00-0BP0
	French	6SE6400-5BA00-0DP0
	Italian	6SE6400-5BA00-0CP0
	Spanish	6SE6400-5BA00-0EP0

1) The CD-ROM contains operating instructions, parameter list, commissioning tools STARTER and DriveMonitor, multilanguage.

2) Available on Internet at <http://www.siemens.com/micromaster>

MICROMASTER 420

Dimension Drawings

MICROMASTER 420 Inverter

Frame size	200 V to 240 V 1/3 AC	380 V to 480 V 3 AC
A	0.12 kW to 0.75 kW	0.37 kW to 1.5 kW
B	1.1 kW to 2.2 kW	2.2 kW to 4 kW
C	3 kW to 5.5 kW	5.5 kW to 11 kW

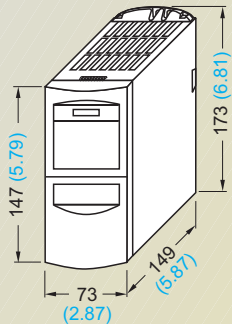

Inverter frame size A

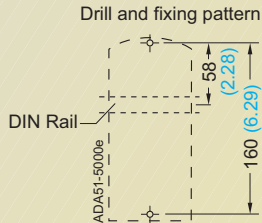

Fixing with
2 bolts M4, 2 nuts M4,
2 washers M4
or snap on to the DIN rail
Tightening torque with
washers fitted: 2.5 Nm
Ventilation clearance required
at top and bottom: 100 mm

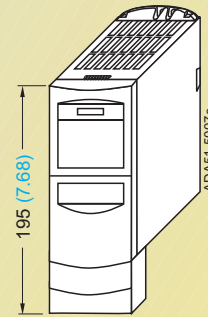

**Inverter frame size A
with gland plate**

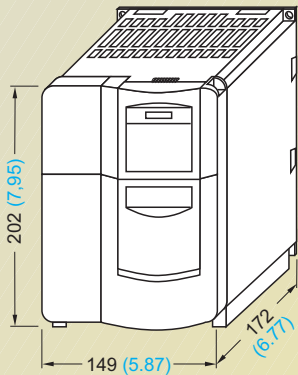

Inverter frame size B

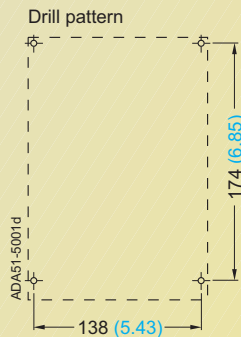

Fixing with
4 bolts M4, 4 nuts M4,
4 washers M4
Tightening torque with
washers fitted: 2.5 Nm
Ventilation clearance required
at top and bottom: 100 mm

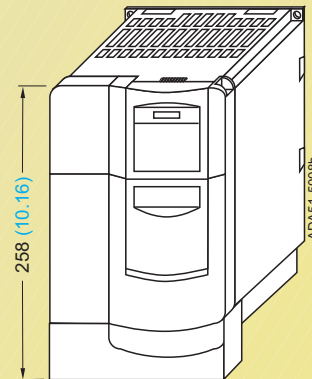

**Inverter frame size B
with gland plate**

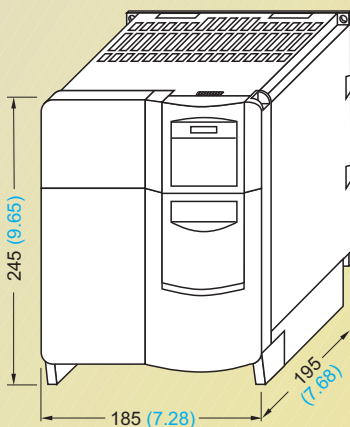

Inverter frame size C

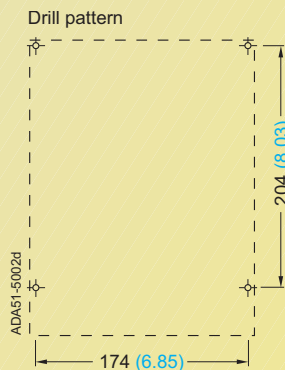

Fixing with
4 bolts M5, 4 nuts M5,
4 washers M5
Tightening torque with
washers fitted: 3.0 Nm
Ventilation clearance required
at top and bottom: 100 mm

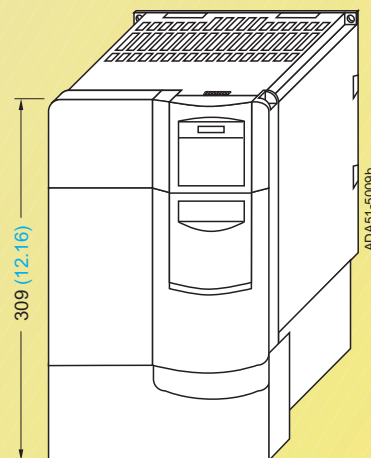

**Inverter frame size C
with gland plate**

With the communications module, the mounting depth increases by 23 mm (0.91 inches).

All dimensions are in mm (values in brackets are in inches)

Filters and Chokes

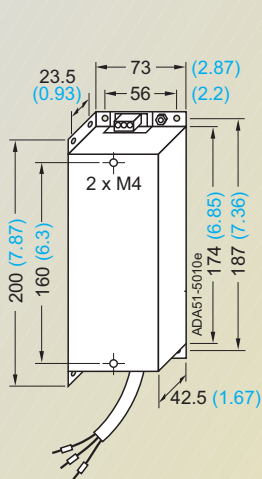

Filter for frame size **A**

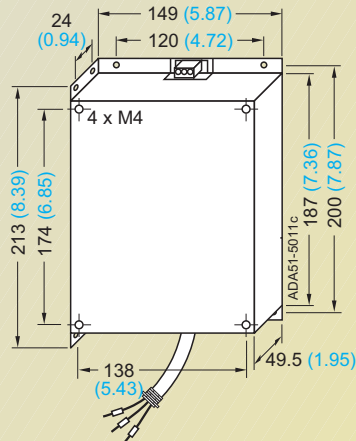

for frame size **B**

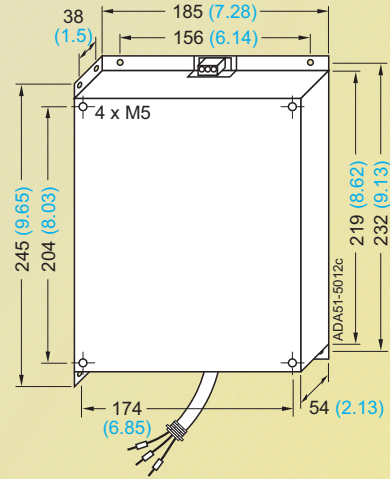

for frame size **C**

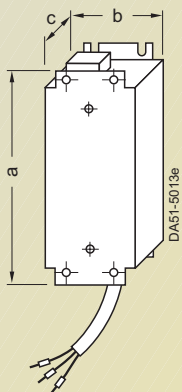

Line commutating choke for frame size **A**

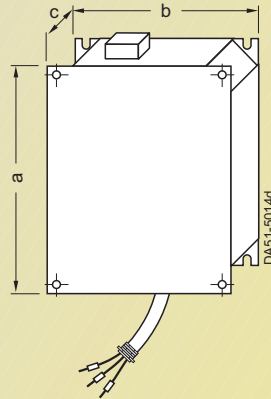

for frame sizes **B** and **C**

Line commutating choke for	Dimensions			Weight (max.) kg
	a	b	c	
frame size A	200 (7.87)	75.5 (2.97)	50 (1.97)	0.8
frame size B	213 (8.39)	150 (5.91)	50 (1.97)	1.3
frame size C	245 (9.65)	185 (7.28)	50 (1.97)	2.3

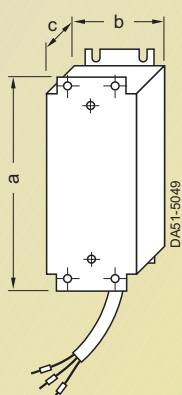

Output choke
6SE6400-3TC00-4AD1

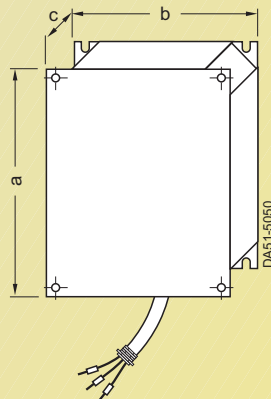

6SE6400-3TC01-0BD0
6SE6400-3TC03-0CD0

Output choke Type 6SE6400-	Dimensions			Weight (max.) kg
	a	b	c	
3TC00-4AD1	200 (7.87)	75.5 (2.97)	50 (1.97)	0.8
3TC01-0BD0	213 (8.39)	150 (5.91)	70 (2.76)	3.4
3TC03-2CD0	245 (9.65)	185 (7.28)	80 (3.15)	5.6

All dimensions are in mm (values in brackets are in inches)

Assembly of inverter and options

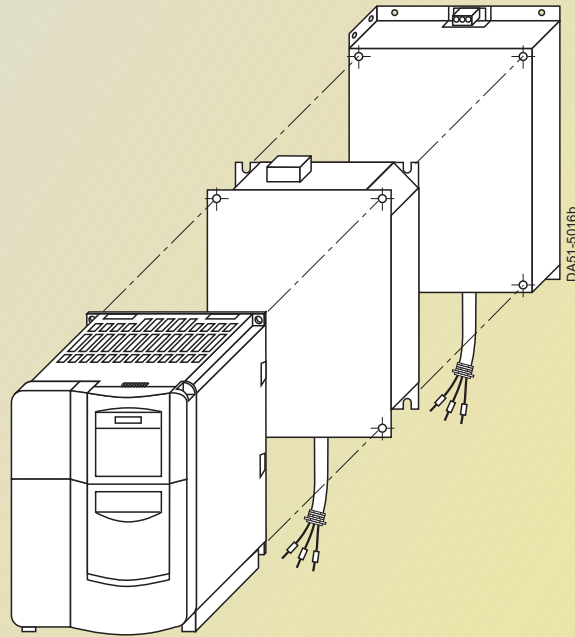

Example:
Assembly of inverter, choke
and filter
If additional accessories are
required, they must be mounted
at the side.

2

Inverter

MICROMASTER 430



3/2	Description
3/4	Circuit Diagrams
3/6	Technical Data
3/8	Selection and Ordering Data
3/9	Options
3/14	Dimension Drawings

MICROMASTER 430

Description



3

Applications

The MICROMASTER 430 inverter is suitable for a variety of variable-speed drive applications. Its flexibility provides for a wide spectrum of applications. It is especially suitable for use with industrial pumps and fans. The inverter is especially characterized by its customer-oriented performance and ease of use. It has more inputs and outputs than the MICROMASTER 420, an optimized operator panel with manual/automatic switchover, and adapted software functionality.

Design

The MICROMASTER 430 inverter has a modular design.

The operator panels and communications modules can be easily exchanged.

Main Characteristics

- Simple commissioning
- Modular construction allows maximum configuration flexibility
- Six programmable isolated digital inputs
- Two scalable analog inputs (0 V to 10 V, 0 mA to 20 mA) can also be used as a 7th/8th digital input
- Two programmable analog outputs (0 mA to 20 mA)
- Three fully programmable relay outputs (30 V DC/5 A, resistive 250 V AC/2 A, inductive)
- Silent motor operation is selectable when using high switching frequencies (observe derating if necessary)
- Complete inverter and motor protection
- Control of up to three additional drives on the basis of PID control (motor staging)
- Operation of drive directly on mains (with external bypass circuit)
- Energy saving mode
- Detects running-dry of pumps (belt failure detection).

Options (Overview)

- Line commutating chokes
- Output chokes
- Gland plates
- BOP basic operator panel 2 (BOP-2) for parameterizing an inverter
- Communications modules
 - PROFIBUS
 - DeviceNet
- PC connection kits
- Assembly kits for mounting the operator panels in the control cabinet doors
- PC commissioning tools, running under Windows 95/98 and NT/2000.

International Standards

- The MICROMASTER 430 inverter complies with the requirements of the EU low-voltage guideline; filtered versions also comply with the EU EMC guideline
- The MICROMASTER 430 inverter has the **CE** marking
- $\text{\textcircled{R}}$ and $\text{\textcircled{C}}$ listed
- c-tick 

Note:

See Appendix for standards.

Mechanical Features

- Modular design
- Operating temperature: -10 °C to +40 °C
- Compact housing as a result of high power density
- Easy cable connection, mains and motor connections are separated for optimum electromagnetic compatibility
- Detachable operator panels
- Screwless control terminals on detachable I/O board.

Performance Features

- Latest IGBT technology
- Digital microprocessor control
- Flux current control (FCC) for improved dynamic response and optimized motor control
- Linear V/f characteristic
- Quadratic V/f characteristic
- Multipoint characteristic (programmable V/f characteristic)
- Flying restart
- Slip compensation
- Automatic restart facility following power failure or fault
- Energy saving mode (stopping e.g. of a pump at low speeds)
- Motor staging (connection and disconnection of additional motors, use of inverter as control drive in a pump cascade)
- Manual/automatic mode
- Load torque detection (detects running-dry of pumps)

Protection Features

- Overload capability
 - **VT mode**
Overload current 1.4 x rated output current (i.e. 140 % overload capability) for 3 s and 1.1 x rated output current (i.e. 110 % overload capability) for 60 s, cycle time 300 s
- Overvoltage/undervoltage protection
- Inverter overtemperature protection
- Special direct connection for PTC or KTY to protect the motor
- Earth fault protection
- Short circuit protection
- I^2t motor thermal protection
- Locked motor protection
- Stall prevention
- Parameter interlock.

Circuit Diagrams

General Circuit Diagram

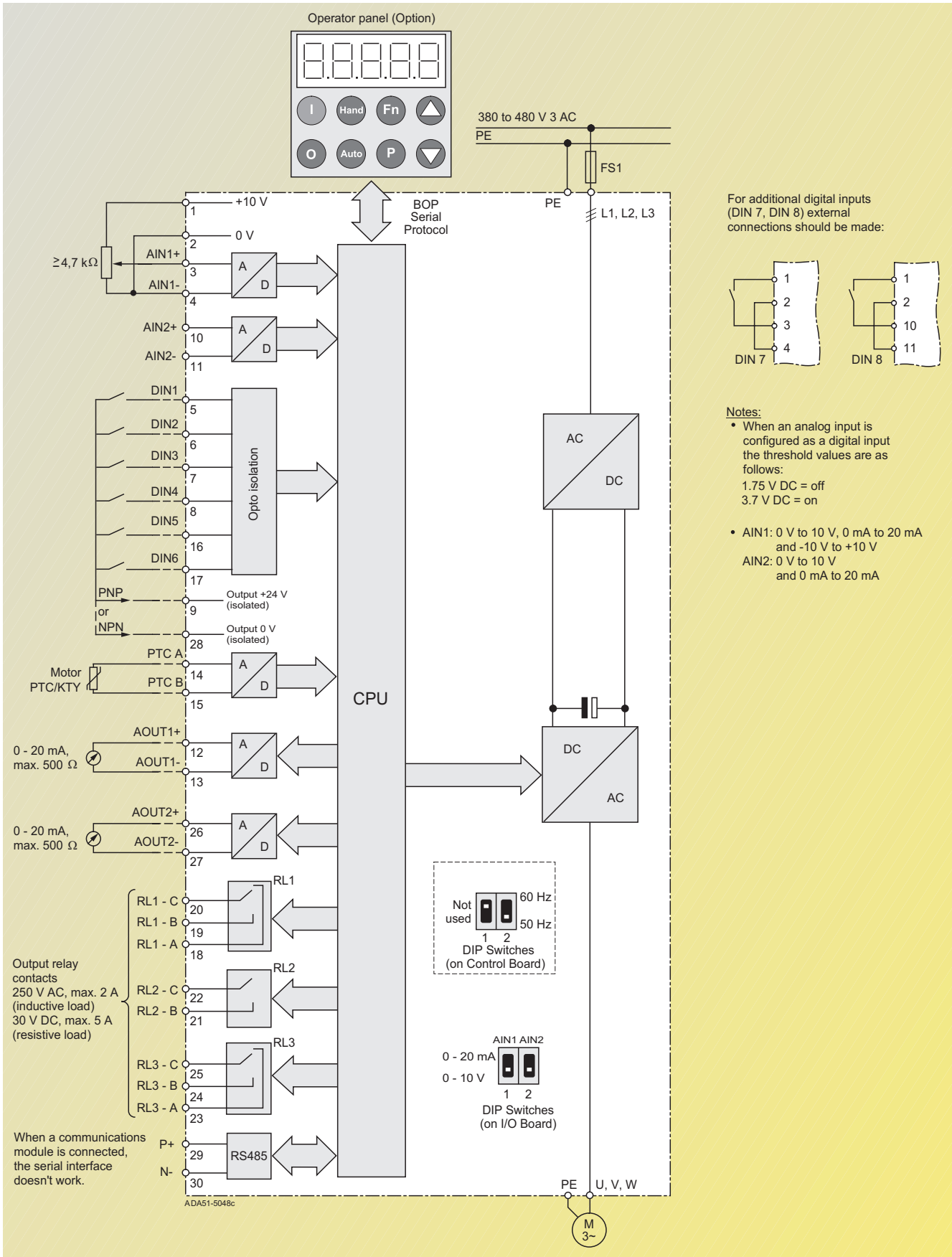

Terminal Connection Diagram

Example frame size C



View A

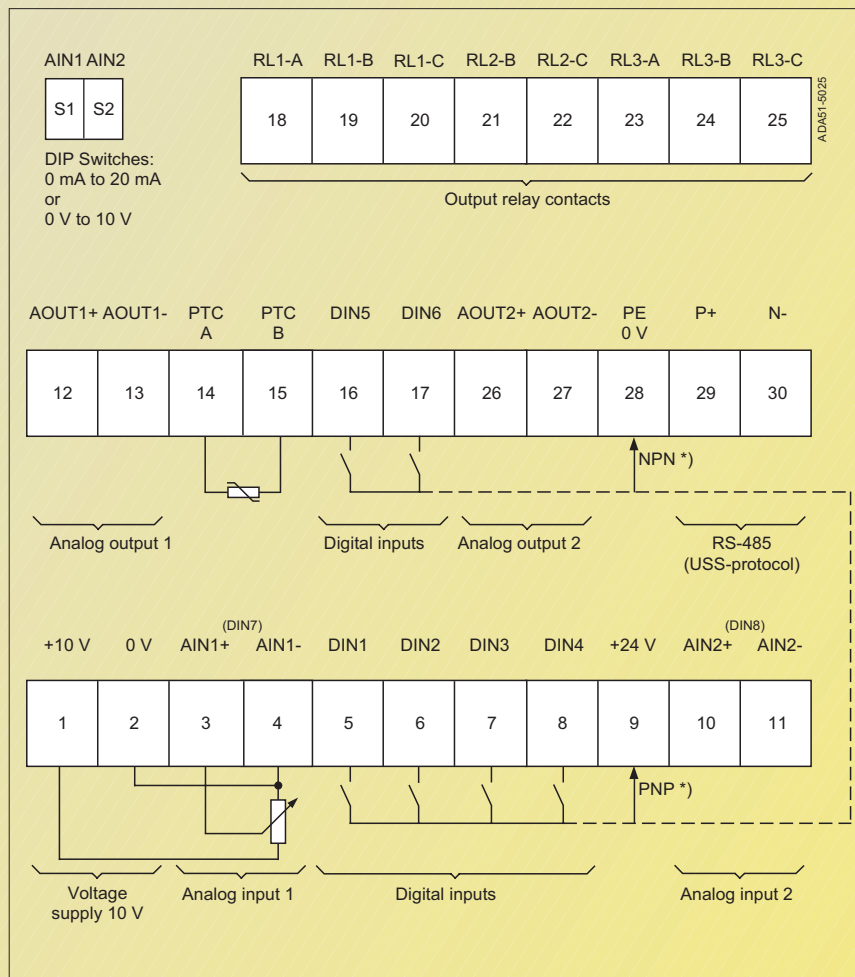





*) PNP or NPN possible

MICROMASTER 430

Technical Data

MICROMASTER 430 Inverter

Input voltage and power ranges	380 V to 480 V 3 AC \pm 10%	7.5 kW to 90 kW (variable torque)																														
Input frequency	47 Hz to 63 Hz																															
Output frequency	0 Hz to 650 Hz																															
Power factor	\geq 0.95																															
Inverter efficiency	96 % to 97 %																															
Overload capability	Overload current 1.4 x rated output current (i.e. 140 % overload capability) for 3 s and 1.1 x rated output current (i.e. 110 % overload capability) for 60 s, cycle time 300 s																															
Inrush current	less than rated input current																															
Control method	linear V/f; quadratic V/f; multipoint characteristic (programmable V/f); flux current control (FCC), energy saving mode																															
PWM frequency	4 kHz (standard) 2 kHz to 16 kHz (in 2 kHz steps)																															
Fixed frequencies	15, programmable																															
Skip frequency bands	4, programmable																															
Setpoint resolution	0.01 Hz digital 0.01 Hz serial 10 bit analog																															
Digital inputs	6 fully programmable isolated digital inputs; switchable PNP/NPN																															
Analog inputs	2 programmable analog inputs • 0 V to 10 V, 0 mA to 20 mA and -10 V to +10 V (AIN1) • 0 V to 10 V and 0 mA to 20 mA (AIN2) • both can be used as 7th/8th digital input																															
Relay outputs	3, configurable, 30 V DC/5 A (resistive), 250 V AC/2 A (inductive)																															
Analog outputs	2, programmable (0/4 mA to 20 mA)																															
Serial interfaces	RS-485, Option RS-232																															
Motor cable length	without output choke max. 50 m (shielded) max. 100 m (unshielded) with output choke max. 200 m (shielded) max. 300 m (unshielded)																															
Electromagnetic compatibility	Optional EMC filters to EN 55 011, Class B (for frame size C), Inverter with internal filter Class A available																															
Braking	DC Braking, Compound Braking																															
Protection level	IP 20																															
Temperature range	-10 °C to +40 °C																															
Storage temperature	-40 °C to +70 °C																															
Relative humidity	95% (non-condensing)																															
Installation height	up to 1000 m above sea level without derating																															
Protection features for	<ul style="list-style-type: none"> • under-voltage • over-voltage • overload • earth faults • short circuits • stall prevention • locked motor • motor over-temperature • inverter over-temperature • parameter PIN protection 																															
Conformity with standards	 ,  ,  , c-tick 																															
CE marking	Conformity with EC low voltage directive 73/23/EC filtered versions also with electromagnetic compatibility directive 89/336/EC																															
Dimensions and weights (without options)	<table border="1"> <thead> <tr> <th>Frame size (FS)</th> <th>H</th> <th>x W</th> <th>x D, max. (mm)</th> <th>Weight, approx. (kg)</th> </tr> </thead> <tbody> <tr> <td>C</td> <td>245</td> <td>x 185</td> <td>x 195</td> <td>5.7</td> </tr> <tr> <td>D</td> <td>520</td> <td>x 275</td> <td>x 245</td> <td>17</td> </tr> <tr> <td>E</td> <td>650</td> <td>x 275</td> <td>x 245</td> <td>22</td> </tr> <tr> <td>F without filter</td> <td>850</td> <td>x 350</td> <td>x 320</td> <td>56</td> </tr> <tr> <td>F with filter</td> <td>1150</td> <td>x 350</td> <td>x 320</td> <td>75</td> </tr> </tbody> </table>	Frame size (FS)	H	x W	x D, max. (mm)	Weight, approx. (kg)	C	245	x 185	x 195	5.7	D	520	x 275	x 245	17	E	650	x 275	x 245	22	F without filter	850	x 350	x 320	56	F with filter	1150	x 350	x 320	75	
Frame size (FS)	H	x W	x D, max. (mm)	Weight, approx. (kg)																												
C	245	x 185	x 195	5.7																												
D	520	x 275	x 245	17																												
E	650	x 275	x 245	22																												
F without filter	850	x 350	x 320	56																												
F with filter	1150	x 350	x 320	75																												

3

Derating Data

Pulse frequency

Rated output (for 400 V 3 AC) kW	Rated output current in A for a pulse frequency of						
	4 kHz	6 kHz	8 kHz	10 kHz	12 kHz	14 kHz	16 kHz
7.5	19.0	17.1	15.2	13.3	11.4	9.5	7.6
11.0	26.0	24.7	23.4	20.8	18.2	15.6	13.0
15.0	32.0	28.8	25.6	22.4	19.2	16.0	12.8
18.5	38.0	36.1	34.2	30.4	26.6	22.8	19.0
22	45.0	40.5	36.0	31.5	27.0	22.5	18.0
30	62.0	55.8	49.6	43.4	37.2	31.0	24.8
37	75.0	71.3	67.5	60.0	52.5	45.0	37.5
45	90.0	81.0	72.0	63.0	54.0	45.0	36.0
55	110.0	93.5	77.0	63.3	49.5	41.3	33.0
75	145.0	123.3	101.5	83.4	65.3	54.4	43.5
90	178.0	138.0	97.9	84.6	71.2	62.3	53.4

Operating temperature

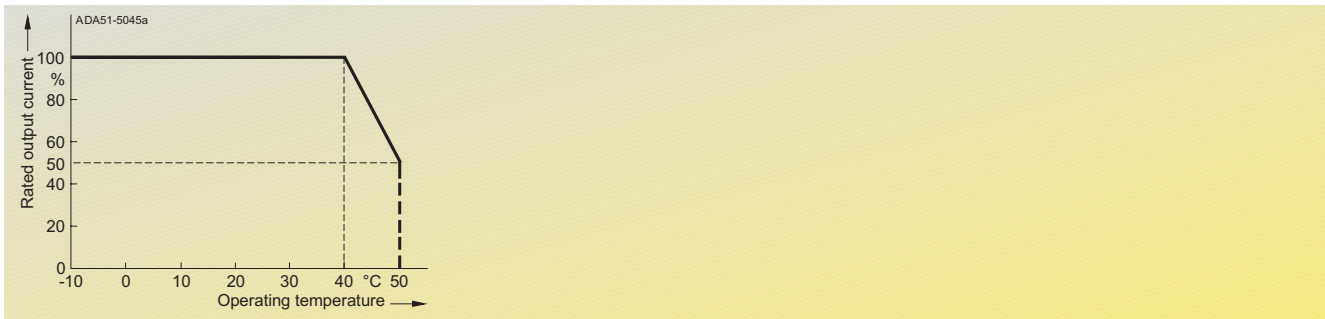

Installation height above sea level

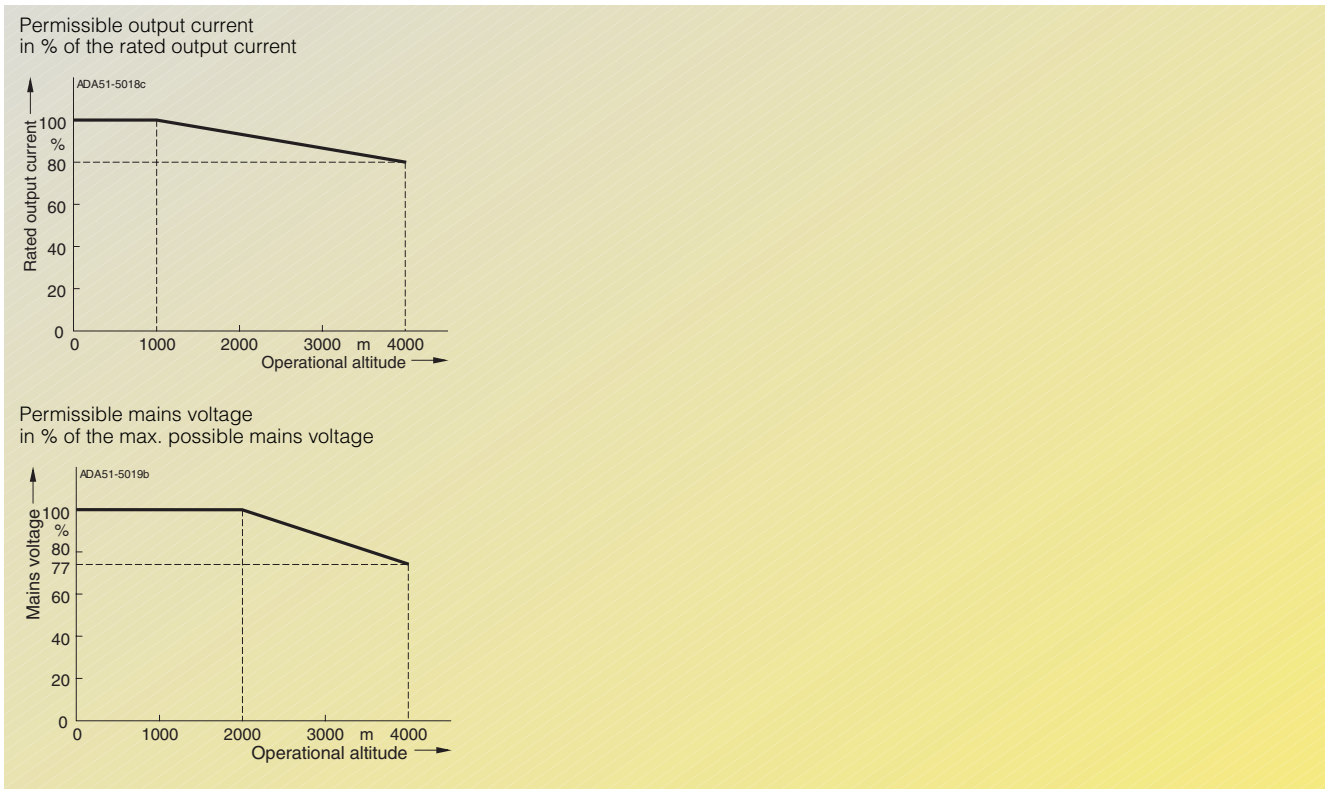

MICROMASTER 430

Selection and Ordering Data

MICROMASTER 430 Inverter

Rated output		Rated input current ¹⁾	Rated output current	Frame size	Ordering No.	
kW	hp	A	A	(FS)	MICROMASTER 430 without filter	MICROMASTER 430 with internal filter Class A ²⁾

Mains operating voltage 380 V to 480 V 3 AC

7.5	10	16.0	19	C	6SE6430-2UD27-5CA0	6SE6430-2AD27-5CA0
11.0	15	22.5	26	C	6SE6430-2UD31-1CA0	6SE6430-2AD31-1CA0
15.0	20	30.5	32	C	6SE6430-2UD31-5CA0	6SE6430-2AD31-5CA0
18.5	25	37.2	38	D	6SE6430-2UD31-8DA0	6SE6430-2AD31-8DA0
22	30	43.3	45	D	6SE6430-2UD32-2DA0	6SE6430-2AD32-2DA0
30	40	59.3	62	D	6SE6430-2UD33-0DA0	6SE6430-2AD33-0DA0
37	50	71.7	75	E	6SE6430-2UD33-7EA0	6SE6430-2AD33-7EA0
45	60	86.6	90	E	6SE6430-2UD34-5EA0	6SE6430-2AD34-5EA0
55	75	103.6	110	F	6SE6430-2UD35-5FA0	6SE6430-2AD35-5FA0
75	100	138.5	145	F	6SE6430-2UD37-5FA0	6SE6430-2AD37-5FA0
90	120	168.5	178	F	6SE6430-2UD38-8FA0	6SE6430-2AD38-8FA0

See Appendix for note on ordering.

All MICROMASTER 430 inverters are supplied with a Status Display Panel SDP. A BOP-2 or other options have to be ordered additionally (see pages 3/11 to 3/13).

Motors for MICROMASTER 430

Catalog M 11 contains selection and ordering data for motors which are particularly suitable for operation with the MICROMASTER 430 inverters (see Appendix for overview).



3

1) Additional conditions: input current at nominal working point, applies to short-circuit voltage of mains supply $V_k \geq 1\%$ referred to rated inverter power and rated mains voltage of 400 V.

2) Use of MICROMASTER inverters with internal filter is not permissible on non-grounded mains supplies.

Variant Dependent Options**EMC filter, Class A**

All other inverters can be supplied with an internal filter Class A.

The requirements are fulfilled using shielded cables with a max. length of 25 m.

Additional EMC filter, Class B

Obtainable for inverters with an internal EMC filter Class A, frame size C.

With this filter, the inverter complies with the emission standard EN 55 011, Class B.

The requirements are fulfilled using shielded cables with a max. length of 25 m.

Leakage currents:

The leakage currents of the inverters with/without filter (internal/external) may exceed 30 mA. Typical values in practice are between 10 mA and 50 mA. The exact values depend on the design, environment and cable lengths. Interference-free operation with residual current operated devices with a trigger value of 30 mA cannot be guaranteed. However, operation with residual current operated devices with a trigger value of 300 mA is possible. Please refer to the Instruction Manual for details.

Line commutating choke

Line commutating chokes are used to smooth voltage peaks or to bridge commutating dips. In addition, line commutating chokes reduce the effects of harmonics on the inverter and the power supply. If the line impedance is < 1%, a line commutating choke must be used in order to reduce the current peaks.

No limits are currently defined in the EN 61 000-3-2 standard for professionally used devices with a connected load > 1 kW. This means that the inverters with an output power ≥ 0.75 kW comply with the EN 61 000-3-2 standard.

Output choke

Output chokes can be supplied for reducing the capacitive currents and dV/dt in the case of motor cables > 50 m (shielded) or > 100 m (unshielded).

Gland plate

Gland plates are available for inverters with frame size C. In frame sizes D, E and F, the gland plates are integrated.

The gland plate enables shielded connection of the power and control cables, ensuring optimum EMC performance. This action ensures compliance with the NEMA 1 directive.

Variant Independent Options**Basic Operator Panel 2 (BOP-2)**

With the BOP-2, individual parameter settings can be made. Values and units are shown on a 5-digit display.



Basic Operator Panel (BOP-2)

A BOP-2 can be used for several inverters. It can be directly mounted on the inverter or in a control-cabinet door using a mounting kit.

PROFIBUS module

For a complete PROFIBUS connection with up to 12 Mbaud. Remote control of the inverter is possible with the PROFIBUS module. Remote control and operation at the inverter can be combined using an operator panel – plugged onto the PROFIBUS module. The latter can be supplied by an external 24 V DC power supply and is thus also active when the inverter is disconnected from the mains.

Connection by means of a 9-pin SUB-D connector (available as an accessory).

DeviceNet module

For networking the inverters to the DeviceNet fieldbus system widely used on the American market. A max. transmission rate of 500 kbaud is possible. Remote control of the module is possible via the DeviceNet module.

Remote control and operation on the inverter can be combined using an operator panel connected to the DeviceNet module.

The connection to the DeviceNet bus system is made using a 5-pin connector with terminal strip.

Connection set for PC to inverter

For controlling an inverter directly from a PC if the appropriate software has been installed (e.g. STARTER) in the PC. Isolated RS-232 adapter board for reliable point-to-point connection to a PC. Includes a Sub-D connector and an RS-232 standard cable (3 m).

Operator panel door mounting kit for single inverter

For mounting an operator panel in a control cabinet door. Degree of protection is IP 56. Contains a cable adapter board with screwless terminals for use with the user's own cables.

Commissioning tools

- **STARTER**
Starter is start-up software for guided commissioning for MICROMASTER 410/420/430/440 frequency inverters under Windows NT/2000. Parameter lists can be read out, altered, stored, entered and printed.
- **DriveMonitor**
DriveMonitor is start-up software for list-oriented programming of frequency inverters under Windows 95/98/NT/2000.



Both programs are included on the Docu CD which is provided with every inverter.

Options

Ordering Data for Variant Dependent Options

The options listed here (filters, chokes, gland plates, fuses and circuit breakers) are inverter specific.

The inverter and the associated options have the same voltage ratings.

All options are certified to , except fuses. The fuses 3NE1 comply with  (corresponds to ).

Mains operating voltage	Rated output kW	Inverter without filter	Order No. of the options		
			Line commutating choke	Output choke	Gland plates
380 V to 480 V 3 AC	7.5	6SE6430-2UD27-5CA0	6SE6400-3CC02-2CD0	6SE6400-3TC03-2CD0	6SE6400-0GP00-0CA0
	11.0	6SE6430-2UD31-1CA0			
	15.0	6SE6430-2UD31-5CA0	6SE6400-3CC03-5CD0		
	18.5	6SE6430-2UD31-8DA0	6SE6400-3CC04-4DD0	6SE6400-3TC05-4DD0	Integrated as standard
	22	6SE6430-2UD32-2DA0		6SE6400-3TC03-8DD0	
	30	6SE6430-2UD33-0DA0	6SE6400-3CC05-2DD0	6SE6400-3TC05-4DD0	
	37	6SE6430-2UD33-7EA0	6SE6400-3CC08-3ED0	6SE6400-3TC08-0ED0	
	45	6SE6430-2UD34-5EA0		6SE6400-3TC07-5ED0	
	55	6SE6430-2UD35-5FA0	6SE6400-3CC11-2FD0	6SE6400-3TC14-5FD0	
	75	6SE6430-2UD37-5FA0		6SE6400-3TC15-4FD0	
	90	6SE6430-2UD38-8FA0	6SE6400-3CC11-7FD0	6SE6400-3TC14-5FD0	

Mains operating voltage	Rated output kW	Inverter without filter	Order No. of the options		Circuit breaker (see Catalog NS K)
			Fuse (see Catalog NS K) 3NA3	3NE1 ()	
380 V to 480 V 3 AC	7.5	6SE6430-2UD27-5CA0	3NA3007	●	3RV1031-4EA10
	11.0	6SE6430-2UD31-1CA0	3NA3012		3RV1031-4FA10
	15.0	6SE6430-2UD31-5CA0	3NA3014		3RV1031-4HA10
	18.5	6SE6430-2UD31-8DA0	3NA3020	3NE1817-0	3RV1042-4KA10
	22	6SE6430-2UD32-2DA0	3NA3022	3NE1818-0	
	30	6SE6430-2UD33-0DA0	3NA3024	3NE1820-0	3RV1042-4MA10
	37	6SE6430-2UD33-7EA0	3NA3030	3NE1021-0	3VL1712-.DD33-....
	45	6SE6430-2UD34-5EA0	3NA3032	3NE1022-0	3VL1716-.DD33-....
	55	6SE6430-2UD35-5FA0	3NA3036	3NE1224-0	3VL3720-.DC36-....
	75	6SE6430-2UD37-5FA0		3NE1225-0	3VL3725-.DC36-....
	90	6SE6430-2UD38-8FA0	3NA3140		3VL4731-.DC36-....

● Use in America requires -listed fuses such as e.g. the Class NON range from Bussmann.

Ordering Data for Variant Dependent Options (continued)

Mains operating voltage	Rated output kW	Inverter with internal filter Class A	Order No. of the options	
			Line commutating choke	Output choke
380 V to 480 V 3 AC	7.5	6SE6430-2AD27-5CA0	6SE6400-3CC02-2CD0	6SE6400-3TC03-2CD0
	11.0	6SE6430-2AD31-1CA0		
	15.0	6SE6430-2AD31-5CA0	6SE6400-3CC03-5CD0	
	18.5	6SE6430-2AD31-8DA0	6SE6400-3CC04-4DD0	6SE6400-3TC05-4DD0
	22	6SE6430-2AD32-2DA0		6SE6400-3TC03-8DD0
	30	6SE6430-2AD33-0DA0	6SE6400-3CC05-2DD0	6SE6400-3TC05-4DD0
	37	6SE6430-2AD33-7EA0	6SE6400-3CC08-3ED0	6SE6400-3TC08-0ED0
	45	6SE6430-2AD34-5EA0		6SE6400-3TC07-5ED0
	55	6SE6430-2AD35-5FA0	6SE6400-3CC11-2FD0	6SE6400-3TC14-5FD0
	75	6SE6430-2AD37-5FA0		6SE6400-3TC15-4FD0
	90	6SE6430-2AD38-8FA0	6SE6400-3CC11-7FD0	6SE6400-3TC14-5FD0

Mains operating voltage	Rated output kW	Inverter with internal filter Class A	Order No. of the options	
			Supplementary EMC filter, Class B	Gland plate
380 V to 480 V 3 AC	7.5	6SE6430-2AD27-5CA0	6SE6400-2FS03-8CD0	6SE6400-0GP00-0CA0
	11.0	6SE6430-2AD31-1CA0		
	15.0	6SE6430-2AD31-5CA0		
	18.5	6SE6430-2AD31-8DA0	–	Integrated as standard
	22	6SE6430-2AD32-2DA0	–	
	30	6SE6430-2AD33-0DA0	–	
	37	6SE6430-2AD33-7EA0	–	
	45	6SE6430-2AD34-5EA0	–	
	55	6SE6430-2AD35-5FA0	–	
	75	6SE6430-2AD37-5FA0	–	
	90	6SE6430-2AD38-8FA0	–	

Mains operating voltage	Rated output kW	Inverter with internal filter Class A	Order No. of the options		
			Fuse (see Catalog NS K) 3NA3	3NE1 (VA)	Circuit breaker (see Catalog NS K)
380 V to 480 V 3 AC	7.5	6SE6430-2AD27-5CA0	3NA3007	●	3RV1031-4EA10
	11.0	6SE6430-2AD31-1CA0	3NA3012		3RV1031-4FA10
	15.0	6SE6430-2AD31-5CA0	3NA3014		3RV1031-4HA10
	18.5	6SE6430-2AD31-8DA0	3NA3020	3NE1817-0	3RV1042-4KA10
	22	6SE6430-2AD32-2DA0	3NA3022	3NE1818-0	
	30	6SE6430-2AD33-0DA0	3NA3024	3NE1820-0	3RV1042-4MA10
	37	6SE6430-2AD33-7EA0	3NA3030	3NE1021-0	3VL1712-.DD33-....
	45	6SE6430-2AD34-5EA0	3NA3032	3NE1022-0	3VL1716-.DD33-....
	55	6SE6430-2AD35-5FA0	3NA3036	3NE1224-0	3VL3720-.DC36-....
	75	6SE6430-2AD37-5FA0		3NE1225-0	3VL3725-.DC36-....
	90	6SE6430-2AD38-8FA0	3NA3140		3VL4731-.DC36-....

● Use in America requires Ⓢ-listed fuses such as e.g. the Class NON range from Bussmann.

Options

Ordering Data for Variant Independent Options

The options listed here are suitable for all MICROMASTER 430.

Option	Order No.
Basic Operator Panel 2 (BOP-2)	6SE6400-0BE00-0AA0
PROFIBUS module	6SE6400-1PB00-0AA0
DeviceNet module	6SE6400-1DN00-0AA0
RS485/PROFIBUS bus connector	6GK1500-0FC00
Connection set for PC to inverter	6SE6400-1PC00-0AA0
Operator panel door mounting kit for single inverter	6SE6400-0PM00-0AA0

Technical data of the communications modules

PROFIBUS module
6SE6400-1PB00-0AA0



DeviceNet module
6SE6400-1DN00-0AA0



Size (height x width x depth)	161 mm x 73 mm x 46 mm	
Degree of protection	IP 20	
Degree of pollution	2 to IEC 60664-1 (DIN VDE 0110/T1), no condensation permitted during operation	
Mechanical strength	to DIN IEC 60068-2-6 (if module installed correctly)	
• Stationary	Deflection	0.15 mm in the frequency range of 10 Hz to 58 Hz
	Acceleration	19.6 m/s ² in the frequency range of 58 Hz to 500 Hz
• Transport	Deflection	3.5 mm in the frequency range of 5 Hz to 9 Hz
	Acceleration	9.8 m/s ² in the frequency range of 9 Hz to 500 Hz
Climatic category (during operation)	3K3 to DIN IEC 60721-3-3	
Cooling method	Natural air cooling	
Permissible ambient or cooling agent temperature		
• in operation	-10 °C to +50 °C (14 °F to 122 °F)	
• during storage and transport	-25 °C to +70 °C (-13 °F to 158 °F)	
Relative humidity (permissible humidity rating)		
• in operation	≤ 85% (non-condensing)	
• during storage and transport	≤ 95%	
Electromagnetic compatibility	Emission	to EN 55011 (1991) Class A
	Interference radiation	to IEC 60801-3 and EN 61000-4-3
Supply voltage	6.5 V ± 5%, max. 300 mA, internal from inverter or 24 V ± 10%, max. 350 mA, external	6.5 V ± 5%, max. 300 mA internal from inverter and 24 V, max. 60 mA from DeviceNet bus
Output voltage	5 V ± 10%, max. 100 mA, galvanically isolated supply	-
	• for terminating the serial interface bus or	
	• for supplying the OLP (Optical Link Plug)	
Data transmission rate	max. 12 Mbaud	125, 250 and 500 kbaud

Documentation

Type of documentation	Language	Order No.
Docu-Pack , supplied with each inverter, containing CD-ROM ¹⁾ and Getting Started Guide ²⁾ (paper version)	Multilanguage	6SE6400-5AE00-1AP0
Operating instructions ²⁾ (paper version)	German	6SE6400-5AE00-0AP0
	English	6SE6400-5AE00-0BP0
	French	6SE6400-5AE00-0DP0
	Italian	6SE6400-5AE00-0CP0
	Spanish	6SE6400-5AE00-0EP0
Parameter list ²⁾ (paper version)	German	6SE6400-5AF00-0AP0
	English	6SE6400-5AF00-0BP0
	French	6SE6400-5AF00-0DP0
	Italian	6SE6400-5AF00-0CP0
	Spanish	6SE6400-5AF00-0EP0

1) The CD-ROM contains operating instructions, parameter list, commissioning tools STARTER and DriveMonitor, multilanguage.

2) Available on Internet at <http://www.siemens.com/micromaster>

MICROMASTER 430

Dimension Drawings

MICROMASTER 430 Inverter

Frame size	380 V to 480 V 3 AC
C	7.5 kW to 15 kW
D	18.5 kW to 30 kW
E	37 kW to 45 kW
F	55 kW to 90 kW

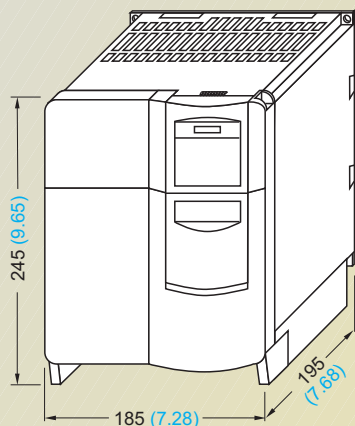

Inverter frame size C

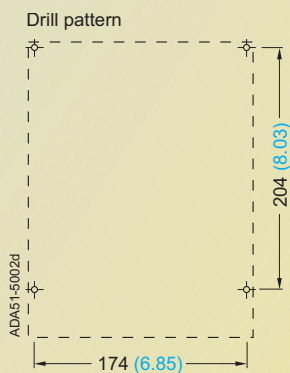

Fixing with
4 bolts M5
4 nuts M5
4 washers M5
Tightening torque with
washers fitted: 3.0 Nm
Ventilation clearance required
at top and bottom: 100 mm

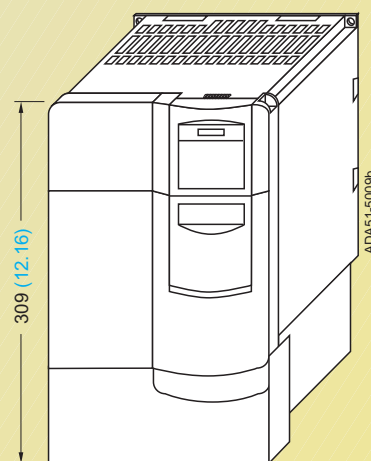

**Inverter frame size C
with gland plates**

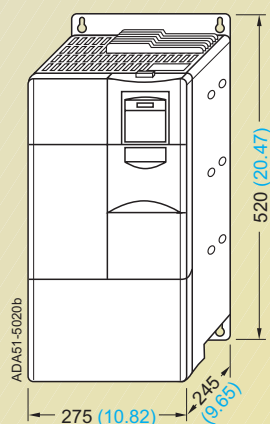

Inverter frame size D

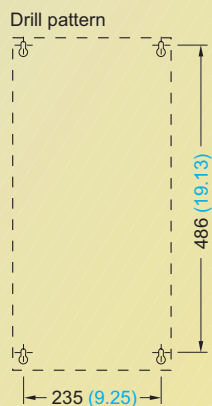

Fixing with
4 bolts M8
4 nuts M8
4 washers M8
Tightening torque with
washers fitted: 3.0 Nm
Ventilation clearance
required at top and bottom:
300 mm

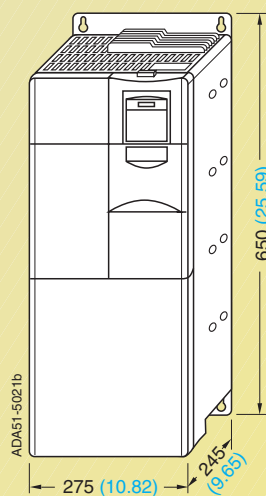

Inverter frame size E



Fixing with
4 bolts M8
4 nuts M8
4 washers M8
Tightening torque with
washers fitted: 3.0 Nm
Ventilation clearance
required at top and bottom:
300 mm

With the communications module the mounting depth increases with frame size C by 23 mm (0.91 inches).

All dimensions are in mm (values in brackets are in inches)

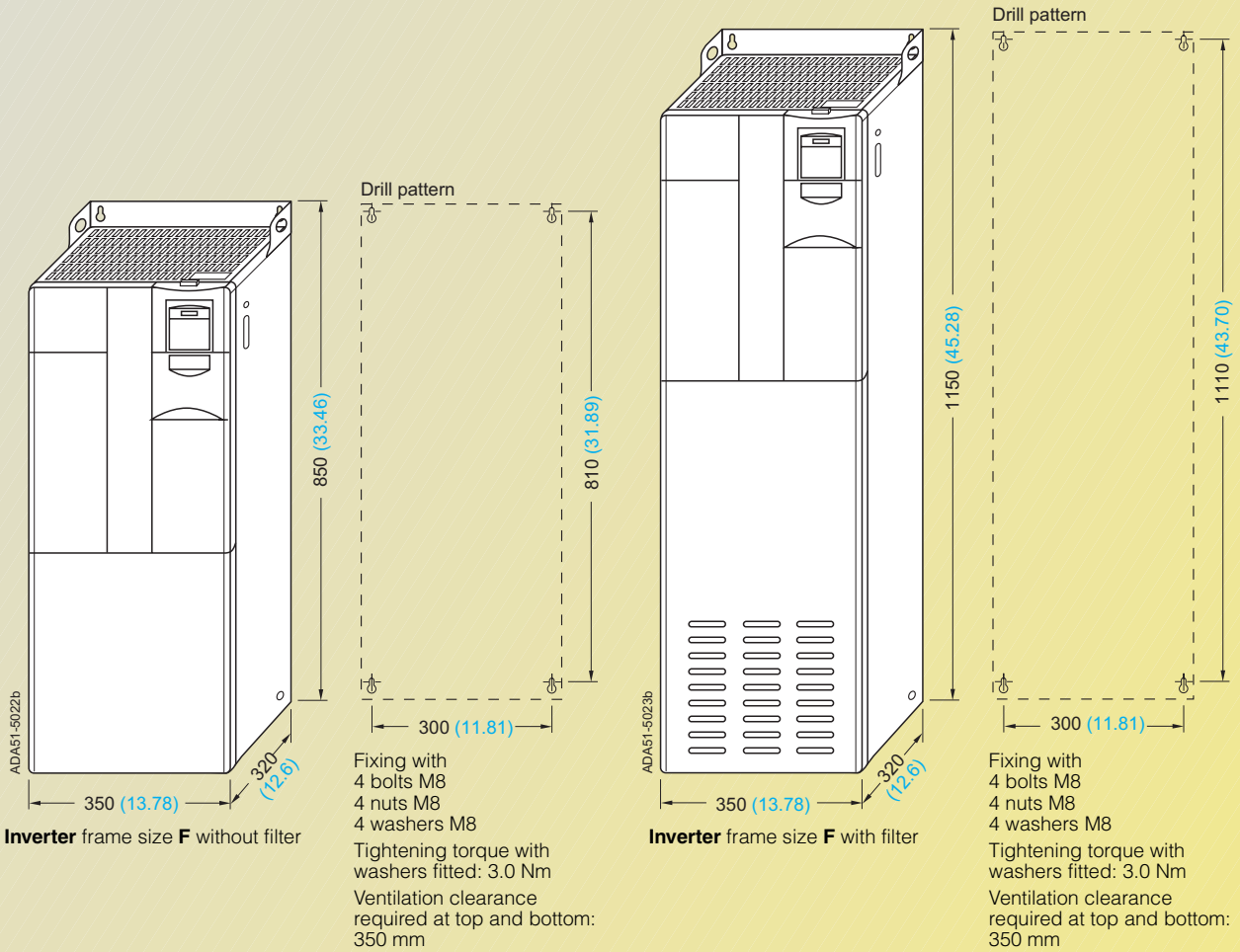

All dimensions are in mm (values in brackets are in inches)

Dimension Drawings

Filters and Chokes

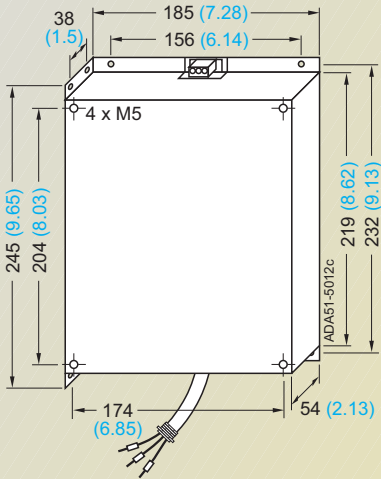

Filter for frame size **C**

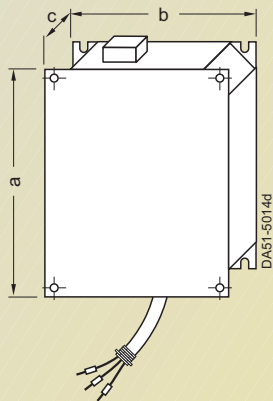

Line commutating choke for	Dimensions			Weight (max.) kg
	a	b	c	
frame size C	245 (9.65)	185 (7.28)	50 (1.97)	2.3

Line commutating choke for frame size **C**

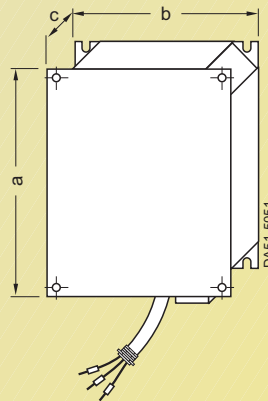

Line commutating choke for	Dimensions			Weight (max.) kg
	a	b	c	
frame size D	520 (20.47)	275 (10.83)	85 (3.35)	9.5
frame size E	650 (25.59)	275 (10.83)	95 (3.74)	17.0

Line commutating choke for frame sizes **D** and **E**

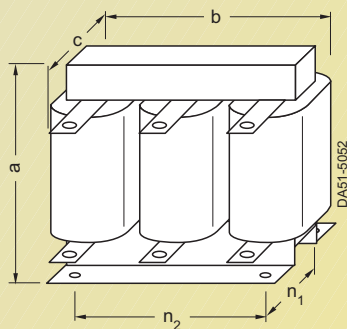

Line commutating choke Type 6SE6400-	for inverter frame size	Dimensions					Weight (max.) kg
		a	b	c	n ₁	n ₂	
3CC11-....	F	210 (8.27)	240 (9.45)	141 (5.55)	109 (4.29)	190 (7.48)	25.0

Line commutating choke for inverter frame size **F**

All dimensions are in mm (values in brackets are in inches)

3

Output chokes

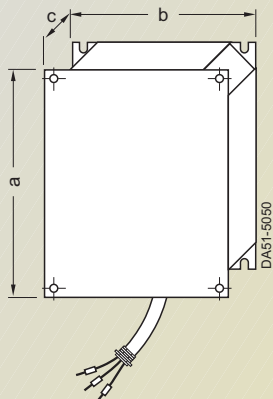

Output choke for frame size **C**

Output choke for	Dimensions			Weight (max.) kg
	a	b	c	
frame size C	245 (9.65)	185 (7.28)	80 (3.15)	5.6

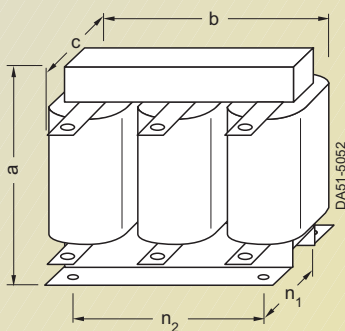

Output choke for inverter frame sizes **D, E and F**

Output choke Type	for inverter frame size (FS)	Dimensions					Weight (max.) kg
		a	b	c	n ₁ (to DIN 41308)	n ₂	
3TC03-8DD0	D	210 (8.27)	225 (8.86)	179 (7.05)	76 (2.99)	176 (6.93)	16.1
3TC05-4DD0	D	210 (8.27)	225 (8.86)	150 (5.91)	76 (2.99)	176 (6.93)	10.7
3TC07-5ED0	E	248 (9.76)	270 (10.63)	209 (8.23)	88 (3.46)	200 (7.87)	24.9
3TC08-0ED0	E	210 (8.27)	225 (8.86)	150 (5.91)	76 (2.99)	176 (6.93)	10.4
3TC14-5FD0	F	321 (12.64)	350 (13.78)	288 (11.34)	120 (4.72)	264 (10.39)	51.5
3TC15-4FD0	F	210 (8.27)	225 (8.86)	150 (5.91)	76 (2.99)	176 (6.93)	11.2

All dimensions are in mm (values in brackets are in inches)

Assembly of inverter and options

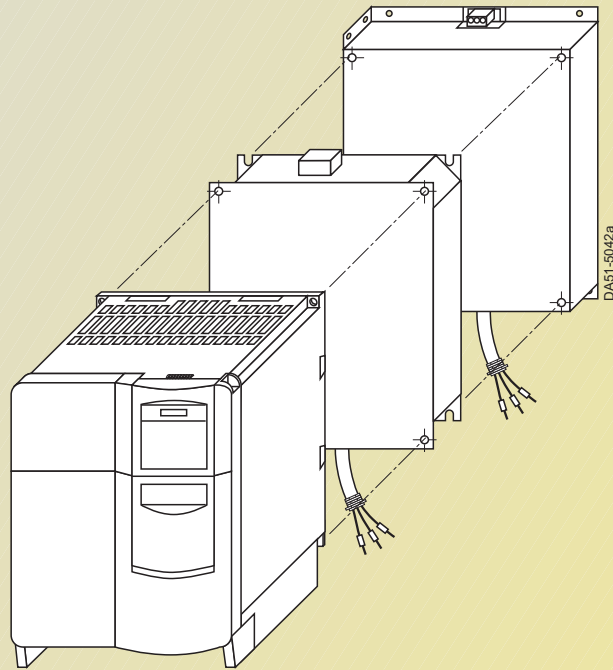

Example:
Assembly of inverter, choke
and filter

If additional accessories
are required, they must be
mounted at the side.

Inverter

MICROMASTER 440



4/2	Description
4/4	Circuit Diagrams
4/6	Technical Data
4/9	Selection and Ordering Data
4/12	Options
4/21	Dimension Drawings

Description



4

Applications

The MICROMASTER 440 inverter is suitable for a variety of variable-speed drive applications. Its flexibility provides for a wide spectrum of applications. These also include cranes and hoisting gear, high-bay warehouses, production machines for food, beverages and tobacco, packaging machines etc.; i.e. applications which require the frequency inverter to have a higher functionality and dynamic response than usual.

The inverter is especially characterized by its customer-oriented performance and ease of use. Its large supply-voltage range enables it to be used all over the world.

Design

The MICROMASTER 440 has a modular design. The operator panels and the modules can be easily exchanged.

International Standards

- The MICROMASTER 440 inverter complies with the requirements of the EU low-voltage guideline; filtered versions also comply with the EU EMC guideline
- The MICROMASTER 440 inverter has the **CE** marking
- **®** and **c®** listed
- c-tick 

Note:

- See Appendix for standards.

Main Characteristics

- Simple commissioning
- Modular construction allows maximum configuration flexibility
- Six programmable isolated digital inputs
- Two scalable analog inputs (0 V to 10 V, 0 mA to 20 mA) can also be used as a 7th/8th digital input
- Two programmable analog outputs (0 mA to 20 mA)
- Three fully programmable relay outputs (30 V DC/5 A, resistive 250 V AC/2 A, inductive)
- Silent motor operation is selectable when using high switching frequencies (observe derating if necessary)
- Complete inverter and motor protection.

Options (Overview)

- EMC filters Class A/B
- Line commutating chokes
- Output chokes
- Gland plates
- BOP basic operator panel for parameterizing an inverter
- AOP advanced operator panel with plain-text and multilingual display
- Communications module – PROFIBUS – DeviceNet
- Pulse encoder evaluation module
- PC connection kits
- Assembly kits for mounting the operator panels in the control cabinet doors
- PC commissioning tools, running under Windows 95/98 and NT/2000.

Mechanical Features

- Modular design
- Operating temperature
0.12 kW to 75 kW:
–10 °C to +50 °C
90 kW to 200 kW:
0 °C to +40 °C
- Compact housing as a result of high power density
- Easy cable connection, mains and motor connections are separated for optimum electromagnetic compatibility
- Detachable operator panels
- Screwless control terminals on detachable I/O board.

Performance Features

- Latest IGBT technology
- Digital microprocessor control
- High-quality Vector Control system
- Flux current control (FCC) for improved dynamic response and optimized motor control
- Linear V/f characteristic
- Quadratic V/f characteristic
- Multipoint characteristic (programmable V/f characteristic)
- Torque control
- Flying restart
- Slip compensation
- Automatic restart facility following power failure or fault
- User-definable function blocks for logic and arithmetic operations
- Kinetic buffering
- Positioning deceleration ramp
- High-grade PID controller (auto-tuning) for simple process control
- Programmable acceleration/deceleration, 0 s to 650 s
- Ramp smoothing
- Fast current limit (FCL) for trip free operation
- Fast, repeatable digital input response time
- Fine speed adjustment using two high resolution 10-bit analog inputs
- Compound braking for rapid controlled braking
- Integral brake chopper (only for 0.12 kW to 75 kW inverters)
- Four skip frequencies
- Removable “Y” capacitor for use on IT mains supplies (with non-grounded mains supplies, the “Y” capacitor must be removed, and an output choke installed).

Protection Features

- Overload capability
 - **CT mode**
0.12 kW to 75 kW:
Overload current
1.5 x rated output current (i.e. 150 % overload capability) for 60 s, cycle time 300 s, and 2 x rated output current (i.e. 200 % overload capability) for 3 s, cycle time 300 s
 - 90 kW to 200 kW:
Overload current
1.36 x rated output current (i.e. 136 % overload capability) for 57 s, cycle time 300 s, and 1.6 x rated output current (i.e. 160 % overload capability) for 3 s, cycle time 300 s
 - **VT mode**
5.5 kW to 90 kW:
Overload current
1.4 x rated output current (i.e. 140 % overload capability) for 3 s, and 1.1 x rated output current (i.e. 110 % overload capability) for 60 s, cycle time 300 s
 - 110 kW to 250 kW:
Overload current
1.5 x rated output current (i.e. 150 % overload capability) for 1 s, and 1.1 x rated output current (i.e. 110 % overload capability) for 59 s, cycle time 300 s
- Overvoltage/undervoltage protection
- Inverter overtemperature protection
- Special direct connection for PTC or KTY to protect the motor
- Earth fault protection
- Short circuit protection
- I^2t motor thermal protection
- Locked motor protection
- Stall prevention
- Parameter interlock.

Circuit Diagrams

General Circuit Diagram

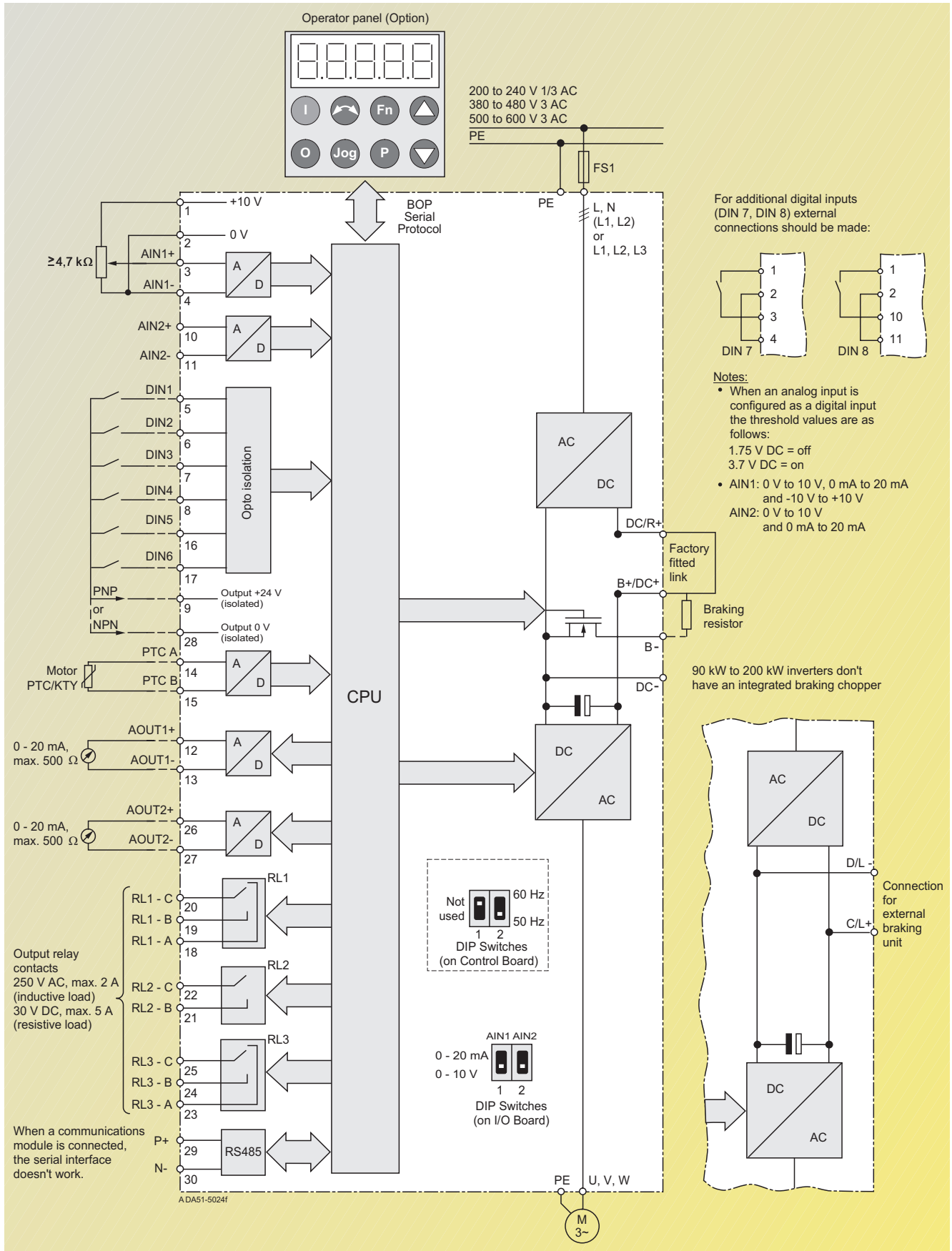

Terminal Connection Diagram

Example frame size FX

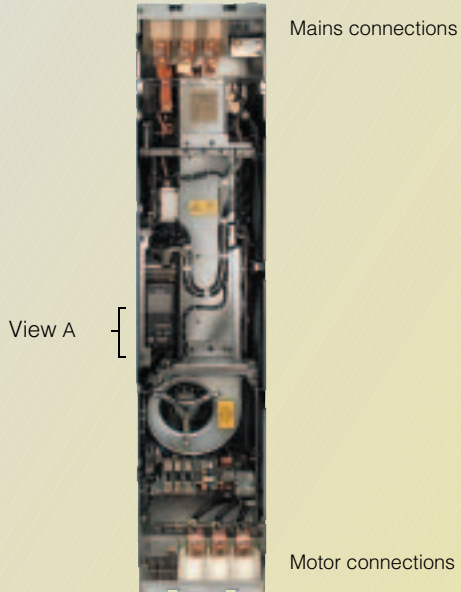

View A

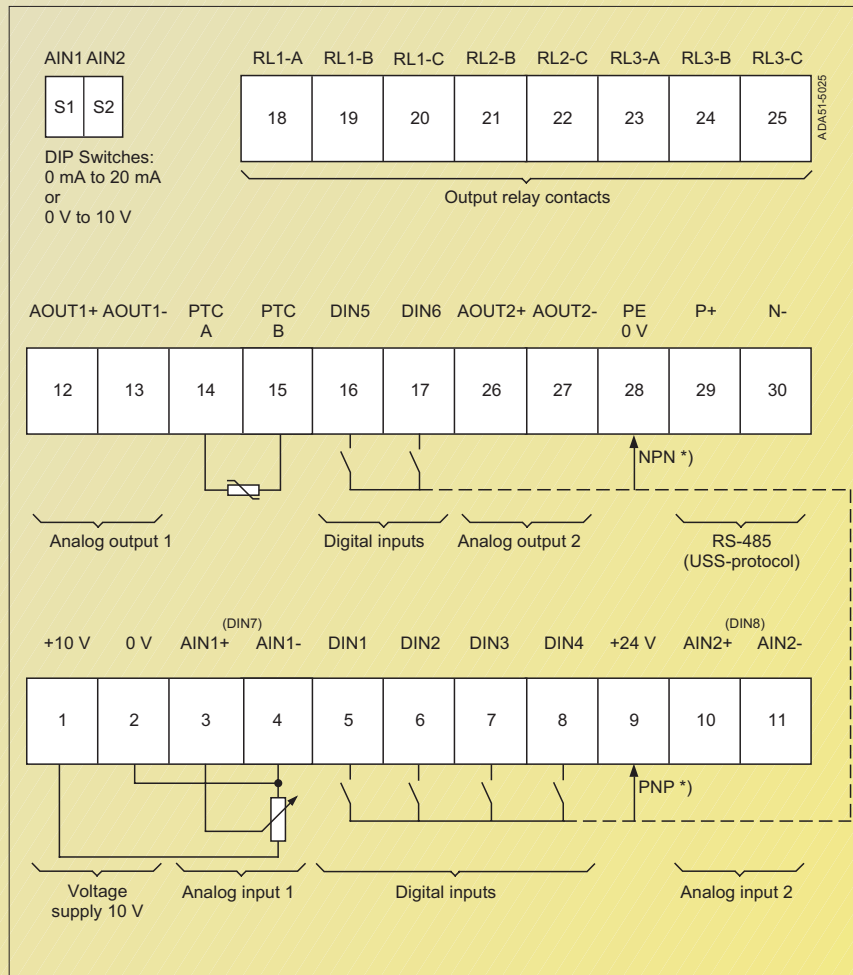

*) PNP or NPN possible

Technical Data

MICROMASTER 440 Inverter

Input voltage and power ranges	200 V to 240 V 1 AC ± 10 % 200 V to 240 V 3 AC ± 10 % 380 V to 480 V 3 AC ± 10 % 500 V to 600 V 3 AC ± 10 %	CT (constant torque) 0.12 kW to 3 kW 0.12 kW to 45 kW 0.37 kW to 200 kW 0.75 kW to 75 kW	VT (variable torque) – 5.5 kW to 45 kW 7.5 kW to 250 kW 1.5 kW to 90 kW
Input frequency	47 Hz to 63 Hz		
Output frequency	0 Hz to 650 Hz (in V/f mode)		
Power factor	≥ 0.95		
Inverter efficiency	96 % to 97 %		
Overload capability	<p>– CT operation</p> <p>0.12 kW to 75 kW Overload current 1.5 x rated output current (i.e. 150 % overload capability) for 60 s, cycle time 300 s, and 2 x rated output current (i.e. 200 % overload capability) for 3 s, cycle time 300 s</p> <p>90 kW to 200 kW Overload current 1.36 x rated output current (i.e. 136 % overload capability) for 57 s, cycle time 300 s, and 1.6 x rated output current (i.e. 160 % overload capability) for 3 s, cycle time 300 s</p> <p>– VT operation</p> <p>5.5 kW to 90 kW Overload current 1.4 x rated output current (i.e. 140 % overload capability) for 3 s and 1.1 x rated output current (i.e. 110 % overload capability) for 60 s, cycle time 300 s</p> <p>110 kW to 250 kW Overload current 1.5 x rated output current (i.e. 150 % overload capability) for 1 s and 1.1 x rated output current (i.e. 110 % overload capability) for 59 s, cycle time 300 s</p>		
Inrush current	less than rated input current		
Control method	Vector control, torque control, linear V/f, quadratic V/f characteristic; multipoint characteristic (programmable V/f characteristic); flux current control (FCC)		
PWM frequency	0.12 kW to 75 kW 90 kW to 200 kW	4 kHz (standard); 16 kHz (standard with 230 V inverters 0.12 kW to 5.5 kW) 2 kHz to 16 kHz (in 2 kHz steps) 2 kHz (standard with VT mode); 4 kHz (standard with CT mode) 2 kHz to 8 kHz (in 2 kHz steps)	
Fixed frequencies	15, programmable		
Skip frequency bands	4, programmable		
Setpoint resolution	0.01 Hz digital 0.01 Hz serial 10 bit analog		
Digital inputs	6 fully programmable isolated digital inputs; switchable PNP/NPN		
Analog inputs	2 programmable analog inputs <ul style="list-style-type: none"> • 0 V to 10 V, 0 mA to 20 mA and –10 V to +10 V (AIN1) • 0 V to 10 V and 0 mA to 20 mA (AIN2) • both can be used as 7th/8th digital input 		
Relay outputs	3, programmable, 30 V DC/5 A (resistive), 250 V AC/2 A (inductive)		
Analog outputs	2, programmable (0/4 mA to 20 mA)		
Serial interfaces	RS-485, optional RS-232		
Motor cable length	0.12 – 75 kW 90 – 250 kW	<p>without output choke max. 50 m (shielded), max. 100 m (unshielded)</p> <p>with output choke max. 200 m (shielded), max. 300 m (unshielded)</p> <p>without output choke max. 100 m (shielded), max. 150 m (unshielded)</p> <p>with output choke in preparation</p>	
Electromagnetic compatibility	0.12 kW to 75 kW	Optional EMC filters to EN 55 011, Class A or Class B (for frame sizes A, B, C), Inverter with internal filter Class A available (frame sizes A, B, C, D, E, F)	
Braking	Resistance braking with DC braking, compound braking, integral brake chopper (integral brake chopper only with 0.12 kW to 75 kW inverters)		
Protection level	IP 20		
Temperature range (without derating)	0.12 kW to 75 kW 90 kW to 200 kW	–10 °C to +50 °C (CT) –10 °C to +40 °C (VT) 0 °C to +40 °C	
Storage temperature	–40 °C to +70 °C		
Humidity	95% (non-condensing)		
Operational altitudes	0.12 kW to 75 kW 90 kW to 200 kW	up to 1000 m above sea level without derating up to 2000 m above sea level without derating	
Protection features for	under-voltage, over-voltage, overload, earth faults, short circuits, stall prevention, locked motor, motor over-temperature, inverter over-temperature, parameter PIN protection		
Conformity with standards	Ⓜ, cⓂ, CE, c-tick		
CE marking	Conformity with EC low voltage directive 73/23/EC filtered versions also with electromagnetic compatibility directive 89/336/EC		
Dimensions and weights (without options)	Frame size (FS)	H x W x D, max. (mm)	Weight, approx. (kg)
	A	173 x 73 x 149	1.3
	B	202 x 149 x 172	3.4
	C	245 x 185 x 195	5.7
	D	520 x 275 x 245	17
	E	650 x 275 x 245	22
	F without filter	850 x 350 x 320	56
	F with filter	1150 x 350 x 320	75
	FX	1555 x 330 x 360	110
	GX	1875 x 330 x 560	190

Derating Data

Pulse frequency

Rated output kW	Rated output current in A for a pulse frequency of						
	4 kHz	6 kHz	8 kHz	10 kHz	12 kHz	14 kHz	16 kHz
Mains operating voltage 200 V 1/3 AC							
0.12 to 5.5	Values correspond to the 4-kHz standard values. No derating, since 16 kHz standard.						
7.5	28.0	26.6	25.2	22.4	19.6	16.8	14.0
11	42.0	37.8	33.6	29.4	25.2	21.0	16.8
15	54.0	48.6	43.2	37.8	32.4	27.0	21.6
18.5	68.0	64.6	61.2	54.4	47.6	40.8	34.0
22	80.0	72.0	64.0	56.0	48.0	40.0	32.0
30	104.0	91.0	78.0	70.2	62.4	57.2	52.0
37	130.0	113.8	97.5	87.8	78.0	71.5	65.0
45	154.0	134.8	115.5	104.0	92.4	84.7	77.0
Mains operating voltage 400 V 3 AC							
0.37	1.3	1.3	1.3	1.3	1.3	1.2	1.0
0.55	1.7	1.7	1.7	1.6	1.5	1.4	1.2
0.75	2.2	2.2	2.2	2.0	1.8	1.5	1.3
1.1	3.1	2.9	2.8	2.5	2.2	1.9	1.6
1.5	4.1	3.7	3.3	2.9	2.5	2.1	1.6
2.2	5.9	5.6	5.3	4.7	4.1	3.5	3.0
3.0	7.7	6.9	6.2	5.4	4.6	3.9	3.1
4.0	10.2	9.2	8.2	7.1	6.1	5.1	4.1
5.5	13.2	11.9	10.6	9.2	7.9	6.6	5.3
7.5	19.0	18.1	17.1	15.2	13.3	11.4	9.5
11.0	26.0	23.4	20.8	18.2	15.6	13.0	10.4
15.0	32.0	30.4	28.8	25.6	22.4	19.2	16.0
18.5	38.0	34.2	30.4	26.6	22.8	19.0	15.2
22	45.0	40.5	36.0	31.5	27.0	22.5	18.0
30	62.0	58.9	55.8	49.6	43.4	37.2	31.0
37	75.0	67.5	60.0	52.5	45.0	37.5	30.0
45	90.0	76.5	63.0	51.8	40.5	33.8	27.0
55	110.0	93.5	77.0	63.3	49.5	41.3	33.0
75	145.0	112.4	79.8	68.9	58.0	50.8	43.5
90	178.0	131.5	101.1	–	–	–	–
110	205.0	151.4	116.5	–	–	–	–
132	250.0	184.7	142.1	–	–	–	–
160	302.0	223.1	171.6	–	–	–	–
200	370.0	273.3	210.2	–	–	–	–
Mains operating voltage 500 V 3 AC							
0.75	1.4	1.2	1.0	0.8	0.7	0.6	0.6
1.5	2.7	2.2	1.6	1.4	1.1	0.9	0.8
2.2	3.9	2.9	2.0	1.6	1.2	1.0	0.8
4.0	6.1	4.6	3.1	2.4	1.8	1.5	1.2
5.5	9.0	6.8	4.5	3.6	2.7	2.3	1.8
7.5	11.0	8.8	6.6	5.5	4.4	3.9	3.3
11.0	17.0	12.8	8.5	6.8	5.1	4.3	3.4
15.0	22.0	17.6	13.2	11.0	8.8	7.7	6.6
18.5	27.0	20.3	13.5	10.8	8.1	6.8	5.4
22	32.0	24.0	16.0	12.8	9.6	8.0	6.4
30	41.0	32.8	24.6	20.5	16.4	14.4	12.3
37	52.0	39.0	26.0	20.8	15.6	13.0	10.4
45	62.0	52.7	43.4	40.3	37.2	32.6	27.9
55	77.0	67.4	57.8	52.0	46.2	42.4	38.5
75	99.0	84.2	69.3	64.4	59.4	52.0	44.6

Technical Data

Derating Data (continued)

Operating temperature

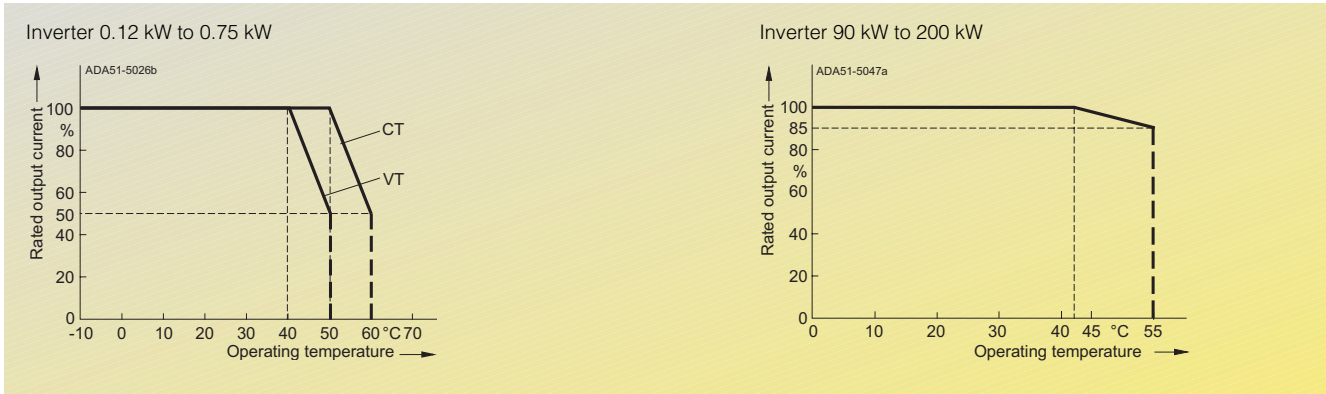

Installation height above sea level

Permissible output current in % of the rated output current

Inverter 0.12 kW to 75 kW (ADA51-5018c)

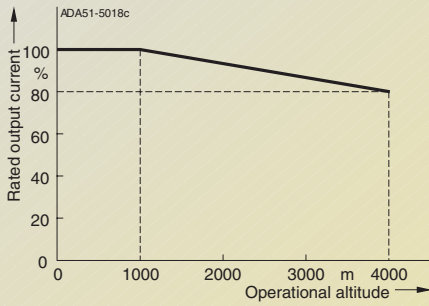

Inverter 90 kW to 200 kW (ADA51-5046)

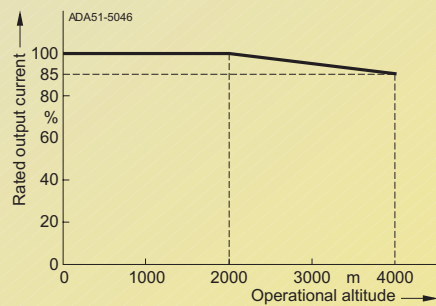

Permissible mains voltage in % of the max. possible mains voltage

Inverter 0.12 kW to 75 kW (ADA51-5019b)

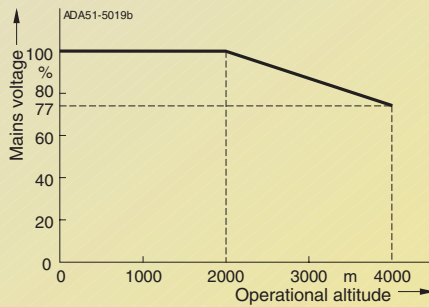

Inverter 90 kW to 200 kW (ADA51-5019b)

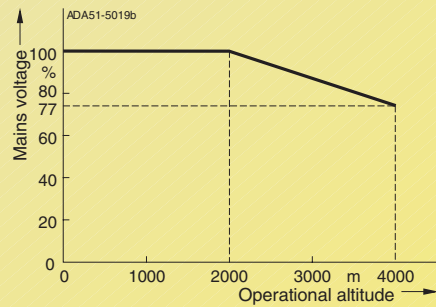

MICROMASTER 440 Inverter without filter

CT (constant torque)			VT (variable torque)				MICROMASTER 440 without filter			
Rated output		Rated input current ¹⁾	Rated output current	Rated output		Rated input current ¹⁾	Rated output current	Frame size (FS)	weight approx. kg	Order No.
kW	hp	A	A	kW	hp	A	A			
Mains operating voltage 200 V to 240 V 1 AC										
0.12	0.16	1.4	0.9	-	-	-	-	A	1.3	6SE6440-2UC11-2AA1
0.25	0.33	2.7	1.7	-	-	-	-	A	1.3	6SE6440-2UC12-5AA1
0.37	0.50	3.7	2.3	-	-	-	-	A	1.3	6SE6440-2UC13-7AA1
0.55	0.75	5.0	3.0	-	-	-	-	A	1.3	6SE6440-2UC15-5AA1
0.75	1.0	6.6	3.9	-	-	-	-	A	1.3	6SE6440-2UC17-5AA1
1.1	1.5	9.6	5.5	-	-	-	-	B	3.3	6SE6440-2UC21-1BA1
1.5	2	13.0	7.4	-	-	-	-	B	3.3	6SE6440-2UC21-5BA1
2.2	3	17.6	10.4	-	-	-	-	B	3.3	6SE6440-2UC22-2BA1
3.0	4	23.7	13.6	-	-	-	-	C	5.5	6SE6440-2UC23-0CA1
Mains operating voltage 200 V to 240 V 3 AC										
0.12	0.16	0.6	0.9	-	-	-	-	A	1.3	6SE6440-2UC11-2AA1
0.25	0.33	1.1	1.7	-	-	-	-	A	1.3	6SE6440-2UC12-5AA1
0.37	0.50	1.6	2.3	-	-	-	-	A	1.3	6SE6440-2UC13-7AA1
0.55	0.75	2.1	3.0	-	-	-	-	A	1.3	6SE6440-2UC15-5AA1
0.75	1.0	2.9	3.9	-	-	-	-	A	1.3	6SE6440-2UC17-5AA1
1.1	1.5	4.1	5.5	-	-	-	-	B	3.3	6SE6440-2UC21-1BA1
1.5	2.0	5.6	7.4	-	-	-	-	B	3.3	6SE6440-2UC21-5BA1
2.2	3.0	7.6	10.4	-	-	-	-	B	3.3	6SE6440-2UC22-2BA1
3.0	4.0	10.5	13.6	-	-	-	-	C	5.5	6SE6440-2UC23-0CA1
4.0	5.0	13.1	17.5	5.5	7.5	17.6	22	C	5.5	6SE6440-2UC24-0CA1
5.5	7.5	17.5	22	7.5	10	26.5	28	C	5.5	6SE6440-2UC25-5CA1
7.5	10	25.3	28	11.0	15	38.4	42	D	17	6SE6440-2UC27-5DA1
11.0	15	37.0	42	15.0	20	50.3	54	D	16	6SE6440-2UC31-1DA1
15.0	20	48.8	54	18.5	25	61.5	68	D	16	6SE6440-2UC31-5DA1
18.5	25	61.0	68	22	30	70.8	80	E	20	6SE6440-2UC31-8EA1
22	30	69.4	80	30	40	96.2	104	E	20	6SE6440-2UC32-2EA1
30	40	94.1	104	37	50	114.1	130	F	55	6SE6440-2UC33-0FA1
37	50	110.6	130	45	60	134.9	154	F	55	6SE6440-2UC33-7FA1
45	60	134.9	154	-	-	-	-	F	55	6SE6440-2UC34-5FA1
Mains operating voltage 380 V to 480 V 3 AC										
0.37	0.50	1.1	1.3	-	-	-	-	A	1.3	6SE6440-2UD13-7AA1
0.55	0.75	1.4	1.7	-	-	-	-	A	1.3	6SE6440-2UD15-5AA1
0.75	1.0	1.9	2.2	-	-	-	-	A	1.3	6SE6440-2UD17-5AA1
1.1	1.5	2.8	3.1	-	-	-	-	A	1.3	6SE6440-2UD21-1AA1
1.5	2.0	3.9	4.1	-	-	-	-	A	1.3	6SE6440-2UD21-5AA1
2.2	3.0	5.0	5.9	-	-	-	-	B	3.3	6SE6440-2UD22-2BA1
3.0	4.0	6.7	7.7	-	-	-	-	B	3.3	6SE6440-2UD23-0BA1
4.0	5.0	8.5	10.2	-	-	-	-	B	3.3	6SE6440-2UD24-0BA1
5.5	7.5	11.6	13.2	7.5	10	16.0	19	C	5.5	6SE6440-2UD25-5CA1
7.5	10	15.4	19	11.0	15	22.5	26	C	5.5	6SE6440-2UD27-5CA1
11.0	15	22.5	26	15.0	20	30.5	32	C	5.5	6SE6440-2UD31-1CA1
15.0	20	30.0	32	18.5	25	37.2	38	D	16	6SE6440-2UD31-5DA1
18.5	25	36.6	38	22	30	43.3	45	D	16	6SE6440-2UD31-8DA1
22	30	43.1	45	30	40	59.3	62	D	16	6SE6440-2UD32-2DA1
30	40	58.7	62	37	50	71.7	75	E	20	6SE6440-2UD33-0EA1
37	50	71.2	75	45	60	86.6	90	E	20	6SE6440-2UD33-7EA1
45	60	85.6	90	55	75	103.6	110	F	56	6SE6440-2UD34-5FA1
55	75	103.6	110	75	100	138.5	145	F	56	6SE6440-2UD35-5FA1
75	100	138.5	145	90	125	168.5	178	F	56	6SE6440-2UD37-5FA1
90	125	168.5	178	110	150	204.5	205	FX	110	6SE6440-2UD38-8FA0
110	150	204.0	205	132	200	244.5	250	FX	110	6SE6440-2UD41-1FA0
132	200	244.5	250	160	250	296.4	302	GX	190	6SE6440-2UD41-3GA0
160	250	296.4	302	200	300	354.0	370	GX	190	6SE6440-2UD41-6GA0
200	300	354.0	370	250	350	442.0	477	GX	190	6SE6440-2UD42-0GA0

1) Additional conditions:
input current at nominal working point, applies to short-

circuit voltage of mains supply
 $V_k \geq 1\%$ referred to rated
inverter power and rated mains

voltage of 240 V or 400 V or
500 V.

MICROMASTER 440

Selection and Ordering Data

MICROMASTER 440 Inverter without filter (continued)

CT (constant torque)			VT (variable torque)				MICROMASTER 440 without filter			
Rated output		Rated input current ¹⁾	Rated output current		Rated input current ¹⁾		Rated output current	Frame size (FS)	weight approx.	Order No.
KW	hp	A	A	KW	hp	A	A	(FS)	kg	
Mains operating voltage 500 V to 600 V 3 AC										
0.75	1.0	2.0	1.4	1.5	2.0	3.2	2.7	C	5.5	6SE6440-2UE17-5CA1
1.5	2.0	3.2	2.7	2.2	3.0	4.4	3.9	C	5.5	6SE6440-2UE21-5CA1
2.2	3.0	4.4	3.9	4.0	5.0	6.9	6.1	C	5.5	6SE6440-2UE22-2CA1
4.0	5.0	6.9	6.1	5.5	7.5	9.4	9	C	5.5	6SE6440-2UE24-0CA1
5.5	7.5	9.4	9	7.5	10	12.6	11	C	5.5	6SE6440-2UE25-5CA1
7.5	10	12.3	11	11.0	15	18.1	17	C	5.5	6SE6440-2UE27-5CA1
11.0	15	18.1	17	15.0	20	24.9	22	C	5.5	6SE6440-2UE31-1CA1
15.0	20	24.2	22	18.5	25	29.8	27	D	16	6SE6440-2UE31-5DA1
18.5	25	29.5	27	22	30	35.1	32	D	16	6SE6440-2UE31-8DA1
22	30	34.7	32	30	40	47.5	41	D	16	6SE6440-2UE32-2DA1
30	40	47.2	41	37	50	57.9	52	E	20	6SE6440-2UE33-0EA1
37	50	57.3	52	45	60	69.4	62	E	20	6SE6440-2UE33-7EA1
45	60	69.0	62	55	75	83.6	77	F	56	6SE6440-2UE34-5FA1
55	75	82.9	77	75	100	113.4	99	F	56	6SE6440-2UE35-5FA1
75	100	113.4	99	90	120	137.6	125	F	56	6SE6440-2UE37-5FA1



See Appendix for note on ordering.

All MICROMASTER 440 inverters are supplied with a Status Display Panel SDP. A Basic Operator Panel BOP, Advanced Operator Panel AOP or other options have to be ordered additionally (see pages 4/14 to 4/20).

Motors for MICROMASTER 440

Catalog M 11 contains selection and ordering data for motors which are particularly suitable for operation with the MICROMASTER 440 inverters (see Appendix for overview).

1) Additional conditions:
input current at nominal working point, applies to short-circuit voltage of mains supply $V_k \geq 1\%$ referred to rated inverter power and rated mains voltage of 240 V or 400 V or 500 V.

MICROMASTER 440 Inverter with internal filter Class A

CT (constant torque)			VT (variable torque)				MICROMASTER 440 with internal filter Class A ²⁾			
Rated output		Rated input current ¹⁾	Rated output current		Rated output current ¹⁾		Rated output current	Frame size (FS)	weight approx. kg	Order No.
kW	hp	A	A	kW	hp	A	A			
Mains operating voltage 200 V to 240 V 1 AC										
0.12	0.16	1.4	0.9	–	–	–	–	A	1.3	6SE6440-2AB11-2AA1
0.25	0.33	2.7	1.7	–	–	–	–	A	1.3	6SE6440-2AB12-5AA1
0.37	0.50	3.7	2.3	–	–	–	–	A	1.3	6SE6440-2AB13-7AA1
0.55	0.75	5.0	3.0	–	–	–	–	A	1.3	6SE6440-2AB15-5AA1
0.75	1.0	6.6	3.9	–	–	–	–	A	1.3	6SE6440-2AB17-5AA1
1.1	1.5	9.6	5.5	–	–	–	–	B	3.4	6SE6440-2AB21-1BA1
1.5	2	13.0	7.4	–	–	–	–	B	3.4	6SE6440-2AB21-5BA1
2.2	3	17.6	10.4	–	–	–	–	B	3.4	6SE6440-2AB22-2BA1
3.0	4	23.7	13.6	–	–	–	–	C	5.7	6SE6440-2AB23-0CA1
Mains operating voltage 200 V to 240 V 3 AC										
3.0	4.0	10.5	13.6	4.0	5.0	13.1	17.5	C	5.7	6SE6440-2AC23-0CA1
4.0	5.0	13.1	17.5	5.5	7.5	17.6	22	C	5.7	6SE6440-2AC24-0CA1
5.5	7.5	17.5	22.0	7.5	10.0	26.5	28	C	5.7	6SE6440-2AC25-5CA1
Mains operating voltage 380 V to 480 V 3 AC										
2.2	3.0	5.0	5.9	–	–	–	–	B	3.4	6SE6440-2AD22-2BA1
3.0	4.0	6.7	7.7	–	–	–	–	B	3.4	6SE6440-2AD23-0BA1
4.0	5.0	8.5	10.2	–	–	–	–	B	3.4	6SE6440-2AD24-0BA1
5.5	7.5	11.6	13.2	7.5	10	16.0	19	C	5.7	6SE6440-2AD25-5CA1
7.5	10	15.4	18.4	11.0	15	22.5	26	C	5.7	6SE6440-2AD27-5CA1
11.0	15	22.5	26	15.0	20	30.5	32	C	5.7	6SE6440-2AD31-1CA1
15.0	20	30.0	32	18.5	25	37.2	38	D	17	6SE6440-2AD31-5DA1
18.5	25	36.6	38	22	30	43.3	45	D	17	6SE6440-2AD31-8DA1
22	30	43.1	45	30	40	59.3	62	D	17	6SE6440-2AD32-2DA1
30	40	58.7	62	37	50	71.7	75	E	22	6SE6440-2AD33-0EA1
37	50	71.2	75	45	60	86.6	90	E	22	6SE6440-2AD33-7EA1
45	60	85.6	90	55	75	103.6	110	F	75	6SE6440-2AD34-5FA1
55	75	103.6	110	75	100	138.5	145	F	75	6SE6440-2AD35-5FA1
75	100	138.5	145	90	125	168.5	178	F	75	6SE6440-2AD37-5FA1



See Appendix for note on ordering.

All MICROMASTER 440 inverters are supplied with a Status Display Panel SDP. A Basic Operator Panel BOP, Advanced Operator Panel AOP or other options have to be ordered additionally (see pages 4/14 to 4/20).

Motors for MICROMASTER 440

Catalog M 11 contains selection and ordering data for motors which are particularly suitable for operation with the MICROMASTER 440 inverters (see Appendix for overview).

1) Additional conditions: input current at nominal working point, applies to short-circuit voltage of mains supply $V_k \geq 1\%$ referred to rated inverter power and rated mains voltage of 240 V or 400 V.

2) Use of MICROMASTER inverters with internal filter is not permissible on non-grounded mains supplies.

Options

Variant Dependent Options

EMC filter, Class A

Filter for inverters without an internal filter, for

- 200 V to 240 V 3 AC, frame sizes A and B
- 380 V to 480 V 3 AC, frame size A.

All other inverters can be supplied with an internal filter Class A.

The requirements are fulfilled using shielded cables with a max. length of 25 m.

EMC filter, Class B

Filter for inverters without an internal filter, for

- 200 V to 240 V 3 AC, frame sizes A and B
- 380 V to 480 V 3 AC, frame size A.

With this filter, the inverter complies with the emission standard EN 55 011, Class B.

The requirements are fulfilled using shielded cables with a max. length of 25 m.

Additional EMC filter, Class B

Obtainable for inverters with an internal EMC filter Class A, frame sizes A, B, C.

With this filter, the inverter complies with the emission standard EN 55 011, Class B.

The requirements are fulfilled using shielded cables with a max. length of 25 m.

Class B filter with low leakage currents

EMC filter for 200 V to 240 V 1 AC inverters, frame sizes A and B, without an internal EMC filter Class A.

With this filter, the inverter complies with the emission standard EN 55 011, Class B. Leakage currents are reduced to < 3.5 mA.

The requirements are fulfilled using shielded cables with a max. length of 5 m.

Leakage currents:

The leakage currents of the inverters with/without filter (internal/external) may exceed 30 mA. Typical values in practice are between 10 mA and 50 mA. The exact values depend on the design, environment and cable lengths. Interference-free operation with residual current operated devices with a trigger value of 30 mA cannot be guaranteed. However, operation with residual current operated devices with a trigger value of 300 mA is possible. Please refer to the Instruction Manual for details.

Line commutating choke

Line commutating chokes are used to smooth voltage peaks or to bridge commutating dips. In addition, line commutating chokes reduce the effects of harmonics on the inverter and the power supply. If the line impedance is < 1 %, a line commutating choke must be used in order to reduce the current peaks.

In line with the EN 61 000-3-2 regulations "Limits for harmonic currents with device input current ≤ 16 A per phase", there are special aspects for drives with 250 W to 550 W and 230-V single-phase supplies which can be used in non-industrial applications (1st environment).

For devices with 250 W and 370 W it is necessary either to fit the recommended input chokes or to apply to the power utility company for authorization to connect the devices to the public power supply.

No limits are currently defined in the EN 61 000-3-2 standard for professionally used devices with a connected load > 1 kW. This means that the inverters with an output power ≥ 0.75 kW comply with the EN 61 000-3-2 standard.

Output choke

Output chokes can be supplied for reducing the capacitive currents and dV/dt in the case of motor cables > 50 m (shielded) or > 100 m (unshielded).

Gland plate

Gland plates are available for inverters with frame sizes A, B and C. In frame sizes D and above, the gland plates are integrated.

The gland plate enables shielded connection of the power and control cables, ensuring optimum EMC performance. This action ensures compliance with the NEMA 1 directive.

Variant Independent Options

Basic Operator Panel (BOP)

With the BOP, individual parameter settings can be made. Values and units are shown on a 5-digit display.



Basic Operator Panel (BOP)

A BOP can be used for several inverters. It can be directly mounted on the inverter or in a control-cabinet door using a mounting kit.

Advanced Operator Panel (AOP)

The AOP enables MICROMASTER 440 parameter sets to be easily read and modified. In contrast to the BOP, the value and meaning of the parameters can be directly displayed in several languages by fast scrolling of the address.



Advanced Operator Panel (AOP)

The AOP is directly plugged into the inverter, or communicates with the latter via a door mounting kit. Together with the "AOP door mounting kit for

multiple inverter control", the AOP permits bus communication with up to 30 inverters at a transmission rate of 38 kbaud (RS485, USS).

For servicing purposes, the AOP furthermore supports the download & upload of complete parameter sets.

PROFIBUS module

For a complete PROFIBUS connection with up to 12 Mbaud. Remote control of the inverter is possible with the PROFIBUS module. Remote control and operation at the inverter can be combined using an operator panel – plugged onto the PROFIBUS module. The latter can be supplied by an external 24 V DC power supply and is thus also active when the inverter is disconnected from the mains.

Connection by means of a 9-pin Sub-D connector (available as an accessory).

DeviceNet module

For networking the inverters to the DeviceNet fieldbus system widely used on the American market. A max. transmission rate of 500 kbaud is possible. Remote control of the module is possible via the DeviceNet module. Remote control and operation on the inverter can be combined using an operator panel connected to the DeviceNet module.

The connection to the DeviceNet bus system is made using a 5-pin connector with terminal strip.

Pulse encoder evaluation module

The pulse encoder evaluation module permits direct connection of the most widely encountered digital pulse encoders to the inverter.

They offer the following functions:

- Zero speed at full load torque
- Extremely accurate speed control
- Increased dynamic response of speed and torque control.

This module can be used with HTL and TTL pulse encoders (High-voltage Transistor Logic, 24 V and Transistor-transistor Logic, 5 V).

Connection set for PC to inverter

For controlling an inverter directly from a PC if the appropriate software has been installed (e.g. STARTER) in the PC. Isolated RS-232 adapter board for reliable point-to-point connection to a PC. Includes a Sub-D connector and an RS-232 standard cable (3 m).

Connection set for PC to AOP

For connecting a PC to an AOP. Offline programming of inverters and archiving of parameter sets possible. Includes a desktop attachment kit for an AOP, an RS-232 standard cable (3 m) with Sub-D connectors and a universal power supply unit.

Operator panel door mounting kit for single inverter

For mounting an operator panel in a control cabinet door. Degree of protection is IP 56. Contains a cable adapter board with screwless terminals for use with the user's own cables.

AOP door mounting kit for multiple inverter (USS)

For mounting an AOP in a control cabinet door. Degree of protection IP 56. The AOP can communicate with several inverters by means of the RS-485 USS protocol. The 4-pin connecting cable from the AOP to the RS-485 terminals of the inverter and to the 24 V user terminal strip is not included.

Commissioning tools

- **STARTER**
Starter is graphic start-up software for guided commissioning for MICROMASTER 410/420/430/440 frequency inverters under Windows NT/2000. Parameter lists can be read out, altered, stored, entered and printed.
- **DriveMonitor**
DriveMonitor is start-up software for list-oriented programming of frequency inverters under Windows 95/98/NT/2000.

Both programs are included on the Docu CD which is provided with every inverter.



MICROMASTER 440

Options

Ordering Data for Variant Dependent Options

The options listed here (filters, chokes, brake resistors, gland plates, fuses and circuit breakers) are inverter specific.

The inverter and the associated options have the same voltage ratings.

All options are certified to , except fuses. The fuses 3NE1 comply with  (corresponds to ).

Mains operating voltage	Rated output kW	Inverter without filter	Order No. of the options EMC filter Class A	EMC filter Class B	Filter Class B with low leakage
200 V to 240 V 1 AC	0.12	6SE6440-2UC11-2AA1	–	–	6SE6400-2FL01-0AB0
	0.25	6SE6440-2UC12-5AA1	–	–	
	0.37	6SE6440-2UC13-7AA1	–	–	
	0.55	6SE6440-2UC15-5AA1	–	–	
	0.75	6SE6440-2UC17-5AA1	–	–	
	1.1	6SE6440-2UC21-1BA1	–	–	
	1.5	6SE6440-2UC21-5BA1	–	–	
	2.2	6SE6440-2UC22-2BA1	–	–	
	3.0	6SE6440-2UC23-0CA1	–	–	
	200 V to 240 V 3 AC	0.12	6SE6440-2UC11-2AA1	6SE6400-2FA00-6AD0	
0.25		6SE6440-2UC12-5AA1	–	–	–
0.37		6SE6440-2UC13-7AA1	–	–	–
0.55		6SE6440-2UC15-5AA1	–	–	–
0.75		6SE6440-2UC17-5AA1	–	–	–
1.1		6SE6440-2UC21-1BA1	6SE6400-2FA01-4BC0	6SE6400-2FB01-4BC0	–
1.5		6SE6440-2UC21-5BA1	–	–	–
2.2		6SE6440-2UC22-2BA1	–	–	–
3.0		6SE6440-2UC23-0CA1	–	–	–
4.0		6SE6440-2UC24-0CA1	–	–	–
5.5		6SE6440-2UC25-5CA1	–	–	–
7.5		6SE6440-2UC27-5DA1	–	–	–
11.0		6SE6440-2UC31-1DA1	–	–	–
15.0		6SE6440-2UC31-5DA1	–	–	–
18.5		6SE6440-2UC31-8EA1	–	–	–
22		6SE6440-2UC32-2EA1	–	–	–
30		6SE6440-2UC33-0FA1	–	–	–
37		6SE6440-2UC33-7FA1	–	–	–
45		6SE6440-2UC34-5FA1	–	–	–
380 V to 480 V 3 AC		0.37	6SE6440-2UD13-7AA1	6SE6400-2FA00-6AD0	6SE6400-2FB00-6AD0
	0.55	6SE6440-2UD15-5AA1	–	–	–
	0.75	6SE6440-2UD17-5AA1	–	–	–
	1.1	6SE6440-2UD21-1AA1	–	–	–
	1.5	6SE6440-2UD21-5AA1	–	–	–
	2.2	6SE6440-2UD22-2BA1	–	–	–
	3.0	6SE6440-2UD23-0BA1	–	–	–
	4.0	6SE6440-2UD24-0BA1	–	–	–
	5.5	6SE6440-2UD25-5CA1	–	–	–
	7.5	6SE6440-2UD27-5CA1	–	–	–
	11.0	6SE6440-2UD31-1CA1	–	–	–
	15.0	6SE6440-2UD31-5DA1	–	–	–
	18.5	6SE6440-2UD31-8DA1	–	–	–
	22	6SE6440-2UD32-2DA1	–	–	–
	30	6SE6440-2UD33-0EA1	–	–	–
	37	6SE6440-2UD33-7EA1	–	–	–
	45	6SE6440-2UD34-5FA1	–	–	–
	55	6SE6440-2UD35-5FA1	–	–	–
	75	6SE6440-2UD37-5FA1	–	–	–
	90	6SE6440-2UD38-8FA0	6SL3000-0BE32-5AA0	–	–
110	6SE6440-2UD41-1FA0	6SL3000-0BE34-4AA0	–	–	
132	6SE6440-2UD41-3GA0	–	–	–	
160	6SE6440-2UD41-6GA0	–	–	–	
200	6SE6440-2UD42-0GA0	6SL3000-0BE36-0AA0	–	–	
500 V to 600 V 3 AC	0.75	6SE6440-2UE17-5CA1	–	–	–
	1.5	6SE6440-2UE21-5CA1	–	–	–
	2.2	6SE6440-2UE22-2CA1	–	–	–
	4.0	6SE6440-2UE24-0CA1	–	–	–
	5.5	6SE6440-2UE25-5CA1	–	–	–
	7.5	6SE6440-2UE27-5CA1	–	–	–
	11.0	6SE6440-2UE31-1CA1	–	–	–
	15.0	6SE6440-2UE31-5DA1	–	–	–
	18.5	6SE6440-2UE31-8DA1	–	–	–
	22	6SE6440-2UE32-2DA1	–	–	–
	30	6SE6440-2UE33-0EA1	–	–	–
	37	6SE6440-2UE33-7EA1	–	–	–
	45	6SE6440-2UE34-5FA1	–	–	–
55	6SE6440-2UE35-5FA1	–	–	–	
75	6SE6440-2UE37-5FA1	–	–	–	

Ordering Data for Variant Dependent Options (continued)

Mains operating voltage	Rated output kW	Inverter without filter	Order No. of the options Line commutating choke	Output choke	Brake resistor
200 V to 240 V 1 AC	0.12	6SE6440-2UC11-2AA1	6SE6400-3CC00-4AB0	6SE6400-3TC00-4AD1	6SE6400-4BC05-0AA0
	0.25	6SE6440-2UC12-5AA1			
	0.37	6SE6440-2UC13-7AA1	6SE6400-3CC01-0AB0		
	0.55	6SE6440-2UC15-5AA1			
	0.75	6SE6440-2UC17-5AA1			
	1.1	6SE6440-2UC21-1BA1	6SE6400-3CC02-6BB0	6SE6400-3TC01-0BD0	6SE6400-4BC11-2BA0
	1.5	6SE6440-2UC21-5BA1			
	2.2	6SE6440-2UC22-2BA1			
	3.0	6SE6440-2UC23-0CA1	6SE6400-3CC03-5CB0	6SE6400-3TC03-2CD0	6SE6400-4BC12-5CA0
	0.12	6SE6440-2UC11-2AA1	6SE6400-3CC00-3AC0	6SE6400-3TC00-4AD1	6SE6400-4BC05-0AA0
200 V to 240 V 3 AC	0.25	6SE6440-2UC12-5AA1			
	0.37	6SE6440-2UC13-7AA1	6SE6400-3CC00-5AC0		
	0.55	6SE6440-2UC15-5AA1			
	0.75	6SE6440-2UC17-5AA1			
	1.1	6SE6440-2UC21-1BA1	6SE6400-3CC00-8BC0	6SE6400-3TC01-0BD0	6SE6400-4BC11-2BA0
	1.5	6SE6440-2UC21-5BA1	6SE6400-3CC01-4BD0		
	2.2	6SE6440-2UC22-2BA1			
	3.0	6SE6440-2UC23-0CA1	6SE6400-3CC01-7CC0	6SE6400-3TC03-2CD0	6SE6400-4BC12-5CA0
	4.0	6SE6440-2UC24-0CA1	6SE6400-3CC03-5CD0		6SE6400-4BC13-0CA0
	5.5	6SE6440-2UC25-5CA1			
	7.5	6SE6440-2UC27-5DA1	6SE6400-3CC05-2DD0	6SE6400-3TC02-8DC0	6SE6400-4BC18-0DA0
	11.0	6SE6440-2UC31-1DA1		6SE6400-3TC05-4DD0	
	15.0	6SE6440-2UC31-5DA1			
	18.5	6SE6440-2UC31-8EA1	6SE6400-3CC08-8EC0	6SE6400-3TC08-0ED0	6SE6400-4BC21-2EA0
	22	6SE6440-2UC32-2EA1			
	30	6SE6440-2UC33-0FA1	6SE6400-3CC11-7FD0	6SE6400-3TC15-4FD0	6SE6400-4BC22-5FA0
	37	6SE6440-2UC33-7FA1			
	45	6SE6440-2UC34-5FA1			
380 V to 480 V 3 AC	0.37	6SE6440-2UD13-7AA1	6SE6400-3CC00-2AD0	6SE6400-3TC01-0BD0	6SE6400-4BD11-0AA0
	0.55	6SE6440-2UD15-5AA1		(not suitable for footprint mounting)	
	0.75	6SE6440-2UD17-5AA1	6SE6400-3CC00-4AD0		
	1.1	6SE6440-2UD21-1AA1			
	1.5	6SE6440-2UD21-5AA1	6SE6400-3CC00-6AD0		
	2.2	6SE6440-2UD22-2BA1	6SE6400-3CC01-0BD0	6SE6400-3TC01-0BD0	6SE6400-4BD12-0BA0
	3.0	6SE6440-2UD23-0BA1			
	4.0	6SE6440-2UD24-0BA1	6SE6400-3CC01-4BD0		
	5.5	6SE6440-2UD25-5CA1	6SE6400-3CC02-2CD0	6SE6400-3TC03-2CD0	6SE6400-4BD16-5CA0
	7.5	6SE6440-2UD27-5CA1			
	11.0	6SE6440-2UD31-1CA1	6SE6400-3CC03-5CD0		
	15.0	6SE6440-2UD31-5DA1	6SE6400-3CC04-4DD0	6SE6400-3TC05-4DD0	6SE6400-4BD21-2DA0
	18.5	6SE6440-2UD31-8DA1		6SE6400-3TC03-8DD0	
	22	6SE6440-2UD32-2DA1	6SE6400-3CC05-2DD0	6SE6400-3TC05-4DD0	
	30	6SE6440-2UD33-0EA1	6SE6400-3CC08-3ED0	6SE6400-3TC08-0ED0	6SE6400-4BD22-2EA0
	37	6SE6440-2UD33-7EA1		6SE6400-3TC07-5ED0	
	45	6SE6440-2UD34-5FA1	6SE6400-3CC11-2FD0	6SE6400-3TC14-5FD0	6SE6400-4BD24-0FA0
	55	6SE6440-2UD35-5FA1		6SE6400-3TC15-4FD0	
	75	6SE6440-2UD37-5FA1	6SE6400-3CC11-7FD0	6SE6400-3TC14-5FD0	
	90	6SE6440-2UD38-8FA0	6SL3000-0CE32-3AA0	in preparation	-
	110	6SE6440-2UD41-1FA0	6SL3000-0CE32-8AA0		-
	132	6SE6440-2UD41-3GA0	6SL3000-0CE33-3AA0		-
160	6SE6440-2UD41-6GA0	6SL3000-0CE35-1AA0		-	
200	6SE6440-2UD42-0GA0			-	
500 V to 600 V 3 AC	0.75	6SE6440-2UE17-5CA1	-	On request	6SE6400-4BE14-5CA0
	1.5	6SE6440-2UE21-5CA1	-		
	2.2	6SE6440-2UE22-2CA1	-		
	4.0	6SE6440-2UE24-0CA1	-		
	5.5	6SE6440-2UE25-5CA1	-		
	7.5	6SE6440-2UE27-5CA1	-		6SE6400-4BE16-5CA0
	11.0	6SE6440-2UE31-1CA1	-		
	15.0	6SE6440-2UE31-5DA1	6SE6400-3CC04-4DD0	6SE6400-3TC02-2DE0	6SE6400-4BE21-3DA0
	18.5	6SE6440-2UE31-8DA1		6SE6400-3TC02-7DE0	
	22	6SE6440-2UE32-2DA1		6SE6400-3TC03-2DE0	
	30	6SE6440-2UE33-0EA1	6SE6400-3CC08-3ED0	6SE6400-3TC05-2EE0	6SE6400-4BE21-8EA0
	37	6SE6440-2UE33-7EA1			
	45	6SE6440-2UE34-5FA1	6SE6400-3CC11-2FD0	6SE6400-3TC06-2FE0	6SE6400-4BE24-2FA0
	55	6SE6440-2UE35-5FA1		6SE6400-3TC08-8FE0	
	75	6SE6440-2UE37-5FA1			

Options

Ordering Data for Variant Dependent Options (continued)

● Use in America requires Ⓢ-listed fuses such as e.g. the Class NON range from Bussmann.

Mains operating voltage	Rated output kW	Inverter without filter	Order No. of the options Gland plate	Fuse (see Catalog NS K)		Circuit-breakers (see Catalog NS K)	
				3NA3	3NE1 (Ⓢ)		
200 V to 240 V 1 AC	0.12	6SE6440-2UC11-2AA1	6SE6400-0GP00-0AA0	3NA3803	●	3RV1021-1DA10	
	0.25	6SE6440-2UC12-5AA1				3RV1021-1GA10	
	0.37	6SE6440-2UC13-7AA1				3RV1021-1HA10	
	0.55	6SE6440-2UC15-5AA1		3NA3805		3RV1021-1KA10	
	0.75	6SE6440-2UC17-5AA1				3RV1021-4AA10	
	1.1	6SE6440-2UC21-1BA1		6SE6400-0GP00-0BA0	3NA3807		3RV1021-4BA10
	1.5	6SE6440-2UC21-5BA1					3RV1031-4EA10
	2.2	6SE6440-2UC22-2BA1			3NA3810		3RV1031-4FA10
	3.0	6SE6440-2UC23-0CA1		6SE6400-0GP00-0CA0	3NA3812		3RV1031-4HA10
	200 V to 240 V 3 AC	0.12		6SE6440-2UC11-2AA1	6SE6400-0GP00-0AA0	3NA3803	●
0.25		6SE6440-2UC12-5AA1		3RV1021-1DA10			
0.37		6SE6440-2UC13-7AA1		3RV1021-1FA10			
0.55		6SE6440-2UC15-5AA1	3NA3805			3RV1021-1GA10	
0.75		6SE6440-2UC17-5AA1				3RV1021-1HA10	
1.1		6SE6440-2UC21-1BA1	6SE6400-0GP00-0BA0	3NA3807			3RV1021-1KA10
1.5		6SE6440-2UC21-5BA1					3RV1021-4AA10
2.2		6SE6440-2UC22-2BA1		3NA3810			3RV1021-4CA10
3.0		6SE6440-2UC23-0CA1	6SE6400-0GP00-0CA0	3NA3812			3RV1031-4EA10
4.0		6SE6440-2UC24-0CA1		3NA3812			3RV1031-4FA10
5.5		6SE6440-2UC25-5CA1		3NA3814			3RV1031-4HA10
7.5		6SE6440-2UC27-5DA1	Integrated as standard	3NA3820		3NE1817-0	3RV1042-4JA10
11.0		6SE6440-2UC31-1DA1		3NA3824		3NE1820-0	3RV1042-4LA10
15.0		6SE6440-2UC31-5DA1					3VL1712-. DD33-....
18.5		6SE6440-2UC31-8EA1		3NA3830		3NE1021-0	
22		6SE6440-2UC32-2EA1				3NE1022-0	3VL1716-. DD33-....
30		6SE6440-2UC33-0FA1		3NA3836		3NE1224-0	3VL3720-. DC36-....
37		6SE6440-2UC33-7FA1		3NA3140		3NE1225-0	3VL3725-. DC36-....
45		6SE6440-2UC34-5FA1					3VL4731-. DC36-....
380 V to 480 V 3 AC		0.37	6SE6440-2UD13-7AA1	6SE6400-0GP00-0AA0		3NA3003	●
	0.55	6SE6440-2UD15-5AA1			3RV1021-1DA10		
	0.75	6SE6440-2UD17-5AA1			3RV1021-1FA10		
	1.1	6SE6440-2UD21-1AA1				3RV1021-1GA10	
	1.5	6SE6440-2UD21-5AA1				3RV1021-1JA10	
	2.2	6SE6440-2UD22-2BA1	6SE6400-0GP00-0BA0		3NA3005		3RV1021-1KA10
	3.0	6SE6440-2UD23-0BA1					3RV1021-4AA10
	4.0	6SE6440-2UD24-0BA1			3NA3007		3RV1021-4BA10
	5.5	6SE6440-2UD25-5CA1	6SE6400-0GP00-0CA0				3RV1031-4EA10
	7.5	6SE6440-2UD27-5CA1			3NA3012		3RV1031-4FA10
	11.0	6SE6440-2UD31-1CA1			3NA3014		3RV1031-4HA10
	15.0	6SE6440-2UD31-5DA1	Integrated as standard		3NA3020	3NE1817-0	3RV1042-4KA10
	18.5	6SE6440-2UD31-8DA1			3NA3022	3NE1818-0	
	22	6SE6440-2UD32-2DA1			3NA3024	3NE1820-0	3RV1042-4MA10
	30	6SE6440-2UD33-0EA1			3NA3030	3NE1021-0	3VL1712-. DD33-....
	37	6SE6440-2UD33-7EA1			3NA3032	3NE1022-0	3VL1716-. DD33-....
	45	6SE6440-2UD34-5FA1			3NA3036	3NE1224-0	3VL3720-. DC36-....
	55	6SE6440-2UD35-5FA1				3NE1225-0	3VL3725-. DC36-....
	75	6SE6440-2UD37-5FA1			3NA3140		3VL4731-. DC36-....
	90	6SE6440-2UD38-8FA0			-	3NE1227-0	On request
110	6SE6440-2UD41-1FA0		-	3NE1230-0			
132	6SE6440-2UD41-3GA0		-	3NE1332-0			
160	6SE6440-2UD41-6GA0		-	3NE1333-0			
200	6SE6440-2UD42-0GA0		-	3NE1435-0			
500 V to 600 V 3 AC	0.75	6SE6440-2UE17-5CA1	6SE6400-0GP00-0CA0	3NA3803-6	●	3RV1021-1DA10	
	1.5	6SE6440-2UE21-5CA1				3RV1021-1GA10	
	2.2	6SE6440-2UE22-2CA1				3RV1021-1JA10	
	4.0	6SE6440-2UE24-0CA1				3RV1021-4AA10	
	5.5	6SE6440-2UE25-5CA1			3NA3805-6	3RV1021-4BA10	
	7.5	6SE6440-2UE27-5CA1			3NA3810-6	3RV1021-4DA10	
	11.0	6SE6440-2UE31-1CA1			3NA3812-6	3RV1031-4FA10	
	15.0	6SE6440-2UE31-5DA1		Integrated as standard	3NA3814-6	3NE1803-0	3RV1031-4HA10
	18.5	6SE6440-2UE31-8DA1			3NA3820-6	3NE1817-0	3RV1042-4JA10
	22	6SE6440-2UE32-2DA1			3NA3822-6	3NE1818-0	3RV1042-4KA10
	30	6SE6440-2UE33-0EA1			3NA3824-6	3NE1820-0	3RV1042-4MA10
	37	6SE6440-2UE33-7EA1					3VL1712-. DD33-....
	45	6SE6440-2UE34-5FA1			3NA3132-6	3NE1022-0	3VL1716-. DD33-....
	55	6SE6440-2UE35-5FA1					3VL3720-. DC36-....
	75	6SE6440-2UE37-5FA1			3NA3136-6	3NE1224-0	3VL3725-. DC36-....

Ordering Data for Variant Dependent Options (continued)

Mains operating voltage	Rated output kW	Inverter with internal filter Class A	Order No. of the options Supplementary EMC filter Class B	Line commutating choke	Output choke
200 V to 240 V 1 AC	0.12	6SE6440-2AB11-2AA1	6SE6400-2FS01-0AB0	6SE6400-3CC00-4AB0	6SE6400-3TC00-4AD1
	0.25	6SE6440-2AB12-5AA1			
	0.37	6SE6440-2AB13-7AA1		6SE6400-3CC01-0AB0	
	0.55	6SE6440-2AB15-5AA1			
	0.75	6SE6440-2AB17-5AA1			
	1.1	6SE6440-2AB21-1BA1	6SE6400-2FS02-6BB0	6SE6400-3CC02-6BB0	
	1.5	6SE6440-2AB21-5BA1			
	2.2	6SE6440-2AB22-2BA1			
3.0	6SE6440-2AB23-0CA1	6SE6400-2FS03-5CB0	6SE6400-3CC03-5CB0	6SE6400-3TC03-2CDO	
200 V to 240 V 3 AC	3.0	6SE6440-2AC23-0CA1	6SE6400-2FS03-8CDO	6SE6400-3CC01-7CC0	6SE6400-3TC03-2CDO
	4.0	6SE6440-2AC24-0CA1		6SE6400-3CC03-5CDO	
	5.5	6SE6440-2AC25-5CA1			
380 V to 480 V 3 AC	2.2	6SE6440-2AD22-2BA1	6SE6400-2FS01-6BD0	6SE6400-3CC01-0BD0	6SE6400-3TC01-0BD0
	3.0	6SE6440-2AD23-0BA1			
	4.0	6SE6440-2AD24-0BA1		6SE6400-3CC01-4BD0	
	5.5	6SE6440-2AD25-5CA1	6SE6400-2FS03-8CDO	6SE6400-3CC02-2CDO	6SE6400-3TC03-2CDO
	7.5	6SE6440-2AD27-5CA1			
	11.0	6SE6440-2AD31-1CA1		6SE6400-3CC03-5CDO	
	15.0	6SE6440-2AD31-5DA1	–	6SE6400-3CC04-4DD0	6SE6400-3TC05-4DD0
	18.5	6SE6440-2AD31-8DA1	–		6SE6400-3TC03-8DD0
	22	6SE6440-2AD32-2DA1	–	6SE6400-3CC05-2DD0	6SE6400-3TC05-4DD0
	30	6SE6440-2AD33-0EA1	–	6SE6400-3CC08-3ED0	6SE6400-3TC08-0ED0
	37	6SE6440-2AD33-7EA1	–		6SE6400-3TC07-5ED0
	45	6SE6440-2AD34-5FA1	–	6SE6400-3CC11-2FD0	6SE6400-3TC14-5FD0
	55	6SE6440-2AD35-5FA1	–		6SE6400-3TC15-4FD0
	75	6SE6440-2AD37-5FA1	–	6SE6400-3CC11-7FD0	6SE6400-3TC14-5FD0

Mains operating voltage	Rated output kW	Inverter with internal filter Class A	Order No. of the options Brake resistor	Gland plate	
200 V to 240 V 1 AC	0.12	6SE6440-2AB11-2AA1	6SE6400-4BC05-0AA0	6SE6400-0GP00-0AA0	
	0.25	6SE6440-2AB12-5AA1			
	0.37	6SE6440-2AB13-7AA1			
	0.55	6SE6440-2AB15-5AA1			
	0.75	6SE6440-2AB17-5AA1			
	1.1	6SE6440-2AB21-1BA1	6SE6400-4BC11-2BA0		6SE6400-0GP00-0BA0
	1.5	6SE6440-2AB21-5BA1			
	2.2	6SE6440-2AB22-2BA1			
3.0	6SE6440-2AB23-0CA1	6SE6400-4BC12-5CA0	6SE6400-0GP00-0CA0		
200 V to 240 V 3 AC	3.0	6SE6440-2AC23-0CA1	6SE6400-4BC12-5CA0	6SE6400-0GP00-0CA0	
	4.0	6SE6440-2AC24-0CA1	6SE6400-4BC13-0CA0		
	5.5	6SE6440-2AC25-5CA1			
380 V to 480 V 3 AC	2.2	6SE6440-2AD22-2BA1	6SE6400-4BD12-0BA0	6SE6400-0GP00-0BA0	
	3.0	6SE6440-2AD23-0BA1			
	4.0	6SE6440-2AD24-0BA1			
	5.5	6SE6440-2AD25-5CA1	6SE6400-4BD16-5CA0	6SE6400-0GP00-0CA0	
	7.5	6SE6440-2AD27-5CA1			
	11.0	6SE6440-2AD31-1CA1			
	15.0	6SE6440-2AD31-5DA1	6SE6400-4BD21-2DA0	Integrated as standard	
	18.5	6SE6440-2AD31-8DA1			
	22	6SE6440-2AD32-2DA1			
	30	6SE6440-2AD33-0EA1	6SE6400-4BD22-2EA0		
	37	6SE6440-2AD33-7EA1			
	45	6SE6440-2AD34-5FA1	6SE6400-4BD24-0FA0		
	55	6SE6440-2AD35-5FA1			
	75	6SE6440-2AD37-5FA1			

Options

Ordering Data for Variant Dependent Options (continued)

Mains operating voltage	Rated output kW	Inverter with internal filter Class A	Order No. of the options		Circuit breaker (see Catalog NS K)
			Fuse (see Catalog NS K) 3NA3	3NE1 (●)	
200 V to 240 V 1 AC	0.12	6SE6440-2AB11-2AA1	3NA3803	●	3RV1021-1DA10
	0.25	6SE6440-2AB12-5AA1			3RV1021-1GA10
	0.37	6SE6440-2AB13-7AA1			3RV1021-1HA10
	0.55	6SE6440-2AB15-5AA1	3NA3805		3RV1021-1KA10
	0.75	6SE6440-2AB17-5AA1			3RV1021-4AA10
	1.1	6SE6440-2AB21-1BA1	3NA3807		3RV1021-4BA10
	1.5	6SE6440-2AB21-5BA1			3RV1031-4EA10
	2.2	6SE6440-2AB22-2BA1	3NA3810		3RV1031-4FA10
	3.0	6SE6440-2AB23-0CA1	3NA3812		3RV1031-4HA10
200 V to 240 V 3 AC	3.0	6SE6440-2AC23-0CA1	3NA3810	●	3RV1031-4EA10
	4.0	6SE6440-2AC24-0CA1	3NA3812		3RV1031-4FA10
	5.5	6SE6440-2AC25-5CA1	3NA3814		3RV1031-4HA10
380 V to 480 V 3 AC	2.2	6SE6440-2AD22-2BA1	3NA3005	●	3RV1021-1KA10
	3.0	6SE6440-2AD23-0BA1			3RV1021-4AA10
	4.0	6SE6440-2AD24-0BA1	3NA3007		3RV1021-4BA10
	5.5	6SE6440-2AD25-5CA1			3RV1031-4EA10
	7.5	6SE6440-2AD27-5CA1	3NA3012		3RV1031-4FA10
	11.0	6SE6440-2AD31-1CA1	3NA3014		3RV1031-4HA10
	15.0	6SE6440-2AD31-5DA1	3NA3020	3NE1817-0	3RV1042-4KA10
	18.5	6SE6440-2AD31-8DA1	3NA3022	3NE1818-0	
	22	6SE6440-2AD32-2DA1	3NA3024	3NE1820-0	3RV1042-4MA10
	30	6SE6440-2AD33-0EA1	3NA3030	3NE1021-0	3VL1712-. DD33-....
	37	6SE6440-2AD33-7EA1	3NA3032	3NE1022-0	3VL1716-. DD33-....
	45	6SE6440-2AD34-5FA1	3NA3036	3NE1224-0	3VL3720-. DC36-....
	55	6SE6440-2AD35-5FA1		3NE1225-0	3VL3725-. DC36-....
75	6SE6440-2AD37-5FA1	3NA3140		3VL4731-. DC36-....	

● Use in America requires @-listed fuses such as e.g. the Class NON range from Bussmann.

Ordering Data for Variant Independent Options

The options listed here are suitable for all MICROMASTER 440 Inverters.

Options	Order No.
Basic Operator Panel (BOP)	6SE6400-0BP00-0AA0
Advanced Operator Panel (AOP)	6SE6400-0AP00-0AA1
PROFIBUS module	6SE6400-1PB00-0AA0
DeviceNet module	6SE6400-1DN00-0AA0
Pulse encoder evaluation module	6SE6400-0EN00-0AA0
RS485/PROFIBUS bus connector	6GK1500-0FC00
Connection set for PC to inverter	6SE6400-1PC00-0AA0
Connection set for PC to AOP	6SE6400-0PA00-0AA0
Operator panel door mounting kit for single inverter	6SE6400-0PM00-0AA0
AOP-door mounting kit for multiple inverter (USS)	6SE6400-0MD00-0AA0

Technical data of the communications modules

		PROFIBUS module 6SE6400-1PB00-0AA0	DeviceNet module 6SE6400-1DN00-0AA0
			
Size (height x width x depth)		161 mm x 73 mm x 46 mm	
Degree of protection		IP 20	
Degree of pollution		2 to IEC 60 664-1 (DIN VDE 0110/T1), no condensation permitted during operation	
Mechanical strength		to DIN IEC 60 068-2-6 (if module installed correctly)	
• Stationary	Deflection	0.15 mm in the frequency range of 10 Hz to 58 Hz	
	Acceleration	19.6 m/s ² in the frequency range of 58 Hz to 500 Hz	
• Transport	Deflection	3.5 mm in the frequency range of 5 Hz to 9 Hz	
	Acceleration	9.8 m/s ² in the frequency range of 9 Hz to 500 Hz	
Climatic category (during operation)		3K3 to DIN IEC 60 721-3-3	
Cooling method		Natural air cooling	
Permissible ambient or cooling agent temperature			
• in operation		-10 °C to +50 °C (14 °F to 122 °F)	
• during storage and transport		-25 °C to +70 °C (-13 °F to 158 °F)	
Relative humidity (permissible humidity rating)			
• in operation		≤ 85 % (non-condensing)	
• during storage and transport		≤ 95 %	
Electromagnetic compatibility		Emission	
	Interference radiation	to EN 55 011 (1991) Class A	
		to IEC 60 801-3 and EN 61 000-4-3	
Supply voltage		6.5 V ± 5 %, max. 300 mA, internal from inverter or 24 V ± 10 %, max. 350 mA, external	6.5 V ± 5 %, max. 300 mA internal from inverter or 24 V, max. 60 mA from DeviceNet bus
Output voltage		5 V ± 10 %, max. 100 mA, galvanically isolated supply • for terminating the serial interface bus or • for supplying the OLP (Optical Link Plug)	–
Data transmission rate		max. 12 Mbaud	125, 250 and 500 kbaud

Options

Variant Independent Options

Technical data of the pulse encoder evaluation module

Pulse encoder evaluation module
6SE6400-0EN00-0AAA



Size (height x width x depth)	161 mm x 73 mm x 42 mm
Degree of protection	IP 20
Degree of pollution	2 to IEC 60664-1 (DIN VDE 0110/T1), no condensation permitted during operation
Mechanical strength	to DIN IEC 60068-2-6 (if module installed correctly)
• Stationary	Deflection 0.15 mm in the frequency range of 10 Hz to 58 Hz
• Transport	Acceleration 19.6 m/s ² in the frequency range of >58 Hz to 500 Hz Deflection 3.5 mm in the frequency range of 5 Hz to 9 Hz Acceleration 9.8 m/s ² in the frequency range of 9 Hz to 500 Hz
Climatic category (during operation)	3K3 to DIN IEC 60721-3-3
Cooling method	Natural air cooling
Permissible ambient or cooling agent temperature	
• in operation	-10 °C to +50 °C (14 °F to 122 °F)
• during storage and transport	-20 °C to +70 °C (-14 °F to 158 °F)
Electromagnetic compatibility	Emission to EN 55 011 (1991) Class A Interference to IEC 60801-3 and EN 61 000-4-3 radiation
Relative humidity (permissible humidity rating)	
• in operation	≤ 85 % (non-condensing)
• during storage and transport	≤ 95 %
Supply voltage	5 V ± 5 %, 330 mA or 18 V non-regulated, 140 mA, short-circuit-proof
Pulse frequency	max. 300 kHz

Documentation

Type of documentation	Language	Order No.
Docu-Pack , supplied with each inverter, containing CD-ROM ¹⁾ and Getting Started Guide ²⁾ (paper version)	Multilanguage	6SE6400-5AD00-1AP0
Operating instruction²⁾ (paper version)	German	6SE6400-5AW00-0AP0
	English	6SE6400-5AW00-0BP0
	French	6SE6400-5AW00-0DP0
	Italian	6SE6400-5AW00-0CP0
	Spanish	6SE6400-5AW00-0EP0
Parameter list²⁾ (paper version)	German	6SE6400-5BB00-0AP0
	English	6SE6400-5BB00-0BP0
	French	6SE6400-5BB00-0DP0
	Italian	6SE6400-5BB00-0CP0
	Spanish	6SE6400-5BB00-0EP0

1) The CD-ROM contains operating instructions, parameter list, commissioning tools STARTER and DriveMonitor, multilanguage.

2) Available on Internet at <http://www.siemens.com/micromaster>

MICROMASTER 440 Inverter

Frame size	200 V to 240 V 1/3 AC	380 V to 480 V 3 AC	500 V to 600 V 3 AC
A	0.12 kW to 0.75 kW	0.37 kW to 1.5 kW	–
B	1.1 kW to 2.2 kW	2.2 kW to 4 kW	–
C	3 kW to 5.5 kW	5.5 kW to 11 kW	0.75 kW to 11 kW

The quoted outputs are valid for CT operation.

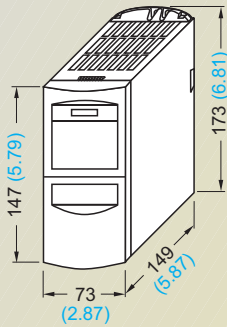

Inverter frame size **A**

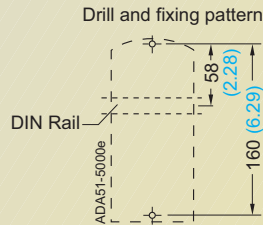

Fixing with
2 bolts M4, 2 nuts M4,
2 washers M4
or snap on to the DIN rail
Tightening torque with
washers fitted: 2.5 Nm
Ventilation clearance required
at top and bottom: 100 mm

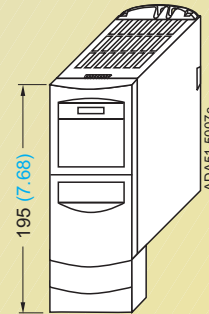

Inverter frame size **A**
with **gland plate**

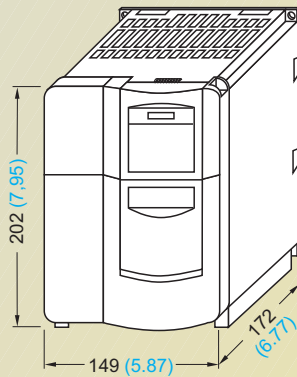

Inverter frame size **B**

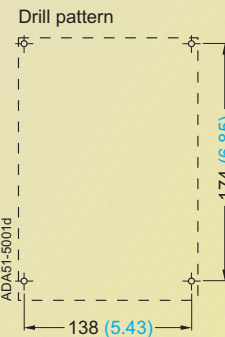

Fixing with
4 bolts M4, 4 nuts M4,
4 washers M4
Tightening torque with
washers fitted: 2.5 Nm
Ventilation clearance required
at top and bottom: 100 mm

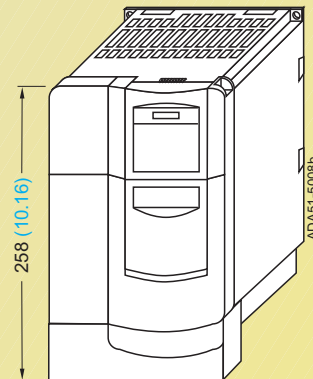

Inverter frame size **B**
with **gland plate**

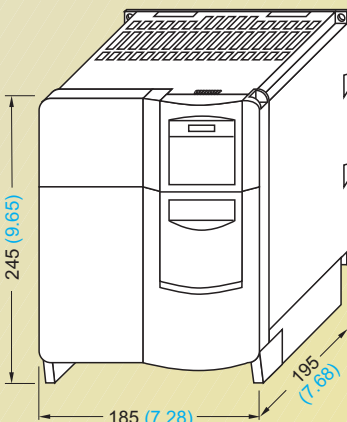

Inverter frame size **C**

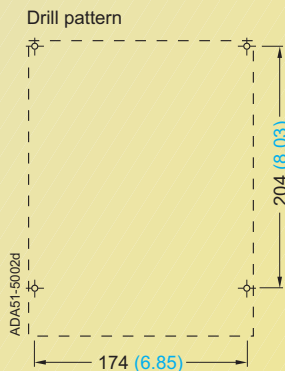

Fixing with
4 bolts M5, 4 nuts M5,
4 washers M5
Tightening torque with
washers fitted: 3.0 Nm
Ventilation clearance required
at top and bottom: 100 mm

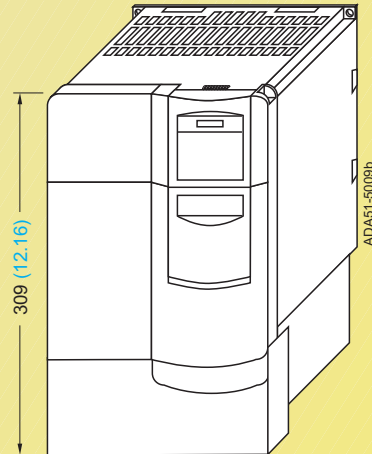

Inverter frame size **C**
with **gland plate**

With a communications module, the mounting depth increases by 23 mm (0.91 Inches).
If a pulse encoder evaluation module is additionally inserted, the mounting depth is increased by a further 23 mm (0.91 Inches).

All dimensions are in mm (values in brackets are in inches)

MICROMASTER 440

Dimension Drawings

MICROMASTER 440 Inverter (continued)

Frame size	200 V to 240 V 3 AC	380 V to 480 V 3 AC	500 V to 600 V 3 AC
D	7.5 kW to 15 kW	15 kW to 22 kW	15 kW to 22 kW
E	18.5 kW to 22 kW	30 kW to 37 kW	30 kW to 37 kW
F	37 kW to 45 kW	45 kW to 75 kW	45 kW to 75 kW

The quoted outputs are valid for CT operation.

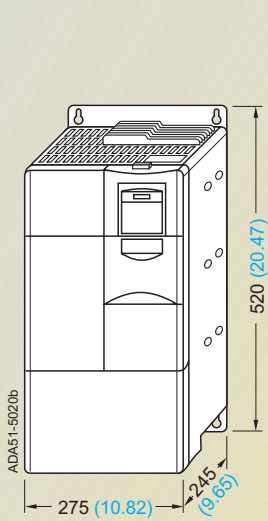

Inverter frame size D

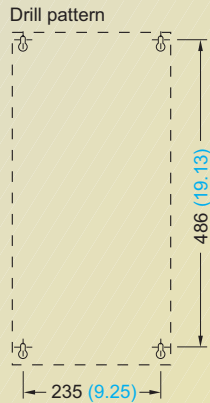

Fixing with 4 bolts M8, 4 nuts M8, 4 washers M8

Tightening torque with washers fitted: 3.0 Nm
Ventilation clearance required at top and bottom: 300 mm

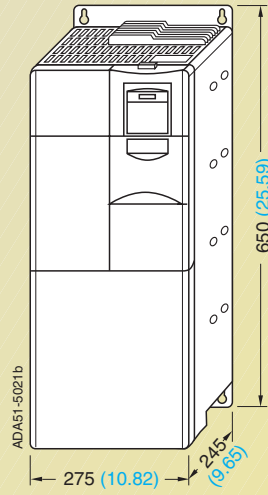

Inverter frame size E

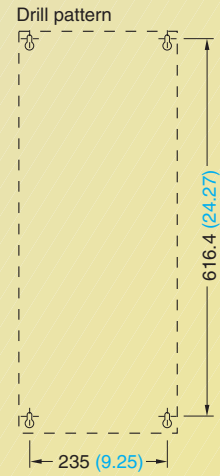

Fixing with 4 bolts M8, 4 nuts M8, 4 washers M8

Tightening torque with washers fitted: 3.0 Nm
Ventilation clearance required at top and bottom: 300 mm

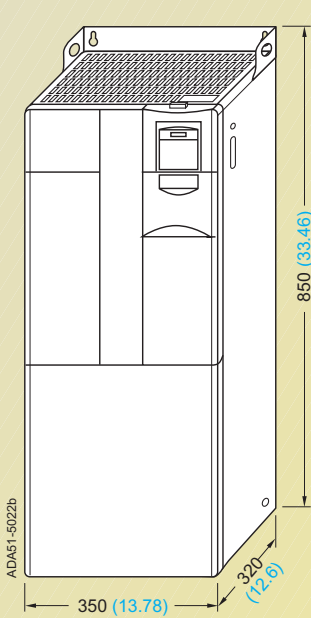

Inverter frame size F without filter



Fixing with 4 bolts M8, 4 nuts M8, 4 washers M8

Tightening torque with washers fitted: 3.0 Nm
Ventilation clearance required at top and bottom: 350 mm

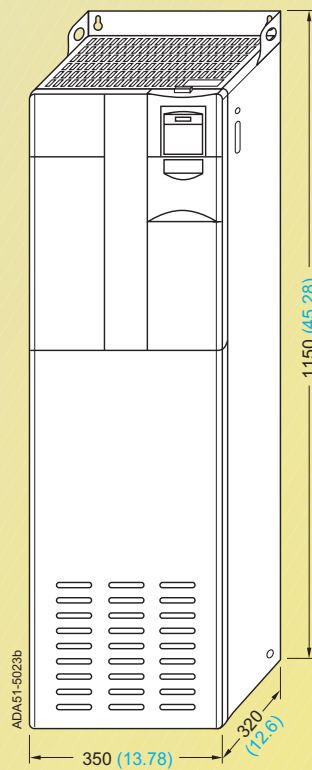

Inverter frame size F with filter

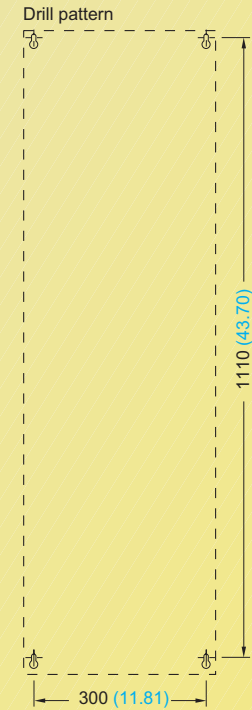

Fixing with 4 bolts M8, 4 nuts M8, 4 washers M8

Tightening torque with washers fitted: 3.0 Nm
Ventilation clearance required at top and bottom: 350 mm

All dimensions are in mm (values in brackets are in inches)

4

Frame size	380 V to 480 V 3 AC
FX	90 kW to 110 kW
GX	132 kW to 200 kW

The quoted outputs are valid for CT operation.

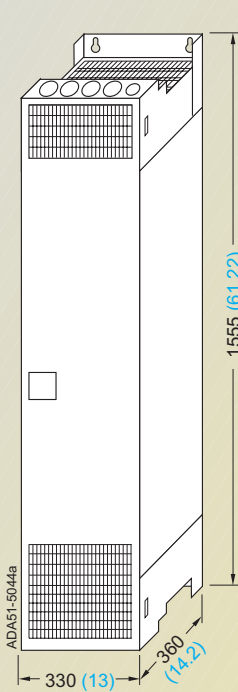

Inverter frame size FX



Fixing with
 4 bolts M8
 4 nuts M8
 4 washers M8
 for connection to DIN rail
 Tightening torque with washers fitted: 13 Nm + 30 %
 Ventilation clearance required
 top: 250 mm
 bottom: 150 mm
 front: 100 mm
 Power connection
 Max. cable cross-section mm² 1 x 185 or 2 x 120
 AWG 1 x 350 or 2 x 4/0
 Barrel lug to DIN 46 235 10 mm

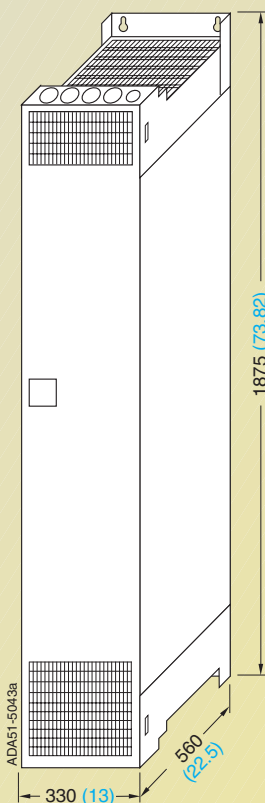

Inverter frame size GX



Fixing with
 4 bolts M8
 4 nuts M8
 4 washers M8
 for connection to DIN rail
 Tightening torque with washers fitted: 13 Nm + 30 %
 Ventilation clearance required
 top: 250 mm
 bottom: 150 mm
 front: 100 mm
 Power connection
 Max. cable cross-section mm² 2 x 240
 AWG 2 x 400
 Barrel lug to DIN 46 235 10 mm

All dimensions are in mm (values in brackets are in inches)

Dimension Drawings

Filters

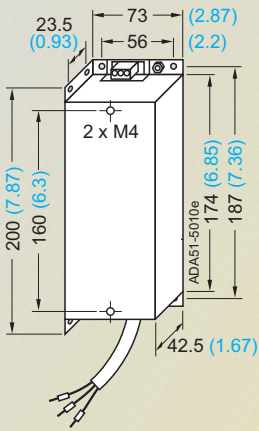

Filter for frame size **A**

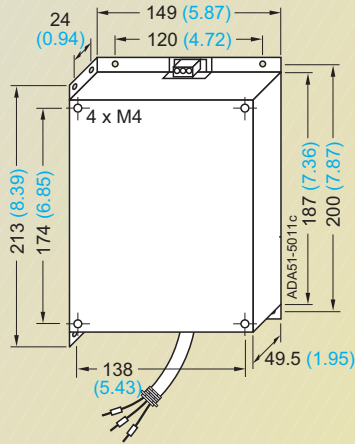

for frame size **B**

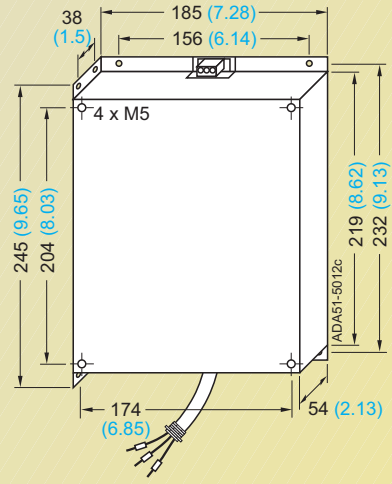

for frame size **C**

All dimensions are in mm (values in brackets are in inches)

Line commutating chokes

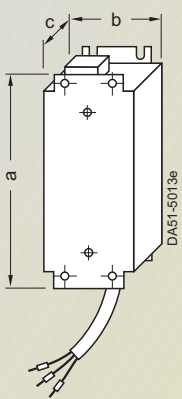

Line commutating choke for frame size **A**

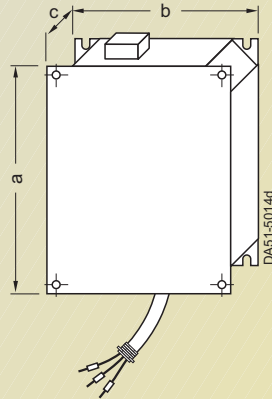

for frame sizes **B** and **C**

Line commutating choke for	Dimensions			Weight (max.) kg
	a	b	c	
frame size A	200 (7.87)	75.5 (2.97)	50 (1.97)	0.8
frame size B	213 (8.39)	150 (5.91)	50 (1.97)	1.3
frame size C	245 (9.65)	185 (7.28)	50 (1.97)	2.3

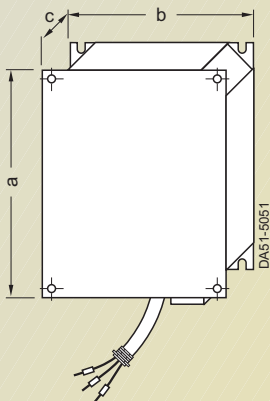

Line commutating choke for frame sizes **D** and **E**

Line commutating choke for	Dimensions			Weight (max.) kg
	a	b	c	
frame size D	520 (20.47)	275 (10.83)	85 (3.35)	9.5
frame size E	650 (25.59)	275 (10.83)	95 (3.74)	17.0

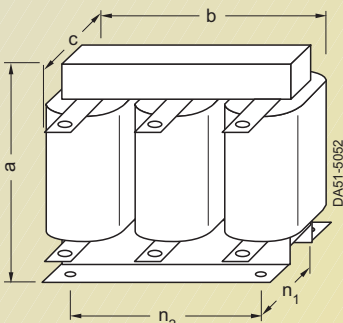

Line commutating choke for inverter frame size **F**

Line commutating choke Type	for inverter frame size (FS)	Dimensions					Weight (max.) kg
		a	b	c	n ₁	n ₂	
6SE6400-3CC11-....	F	210 (8.27)	240 (9.45)	141 (5.55)	109 (4.29)	190 (7.48)	25.0

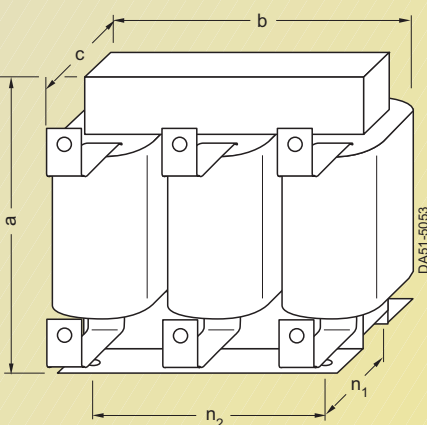

Line commutating choke for inverter frame sizes **FX** and **GX**

Line commutating choke Type	for inverter frame size (FS)	Dimensions					Weight (max.) kg
		a	b	c	n ₁	n ₂	
0CE32-....	FX	248 (9.76)	255 (10.04)	203 (7.99)	101 (3.98)	200 (7.87)	24.0
0CE33-....	GX	248 (9.76)	255 (10.04)	203 (7.99)	101 (3.98)	200 (7.87)	25.0
0CE35-....	GX	269 (10.59)	275 (10.83)	210 (8.27)	118 (4.65)	224 (8.82)	35.0

All dimensions are in mm (values in brackets are in inches)

Dimension Drawings

Output chokes

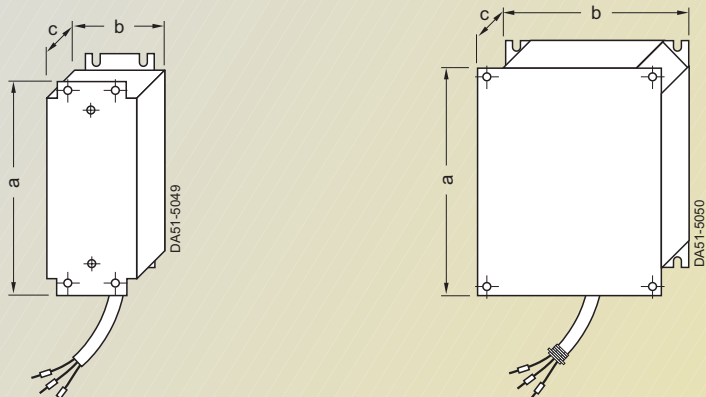

Output choke
6SE6400-3TC00-4AD1

6SE6400-3TC01-0BD0
6SE6400-3TC03-1CD0

Output choke Type 6SE6400-	Dimensions			Weight (max.) kg
	a	b	c	
3TC00-4AD1	200 (7.87)	75.5 (2.97)	50 (1.97)	0.8
3TC01-0BD0	213 (8.39)	150 (5.91)	70 (2.76)	3.4
3TC03-2DC0	245 (9.65)	185 (7.28)	80 (3.15)	5.6

Figure 1

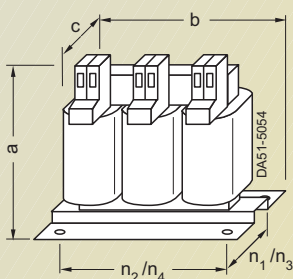
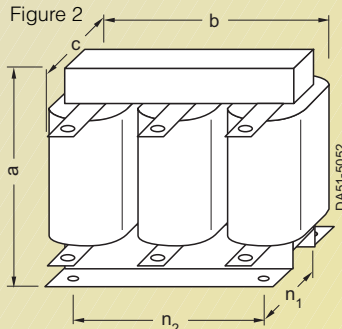

Figure 2



Output choke Type 6SE6400-	for inverter frame size (FS)	Figure No.	Dim.			to DIN 41 308		to DIN EN 60 852-4		Weight (max.) kg
			a	b	c	n ₁	n ₂	n ₃	n ₄	
3TC02-2DE0	D	1	122 (4.80)	124 (4.88)	73 (2.87)	42 (1.65)	¹⁾	53 (2.09)	112 (4.41)	1.2
3TC02-7DE0	D	1	139 (5.47)	148 (5.83)	78 (3.07)	49 (1.93)	90 (3.54)	58 (2.28)	136 (5.35)	2.5
3TC02-8DC0	D	1	122 (4.80)	124 (4.88)	73 (2.87)	42 (1.65)	¹⁾	53 (2.09)	112 (4.41)	1.3
3TC03-2DE0	D	2	210 (8.27)	225 (8.86)	179 (7.05)	76 (2.99)	176 (6.93)	-	-	16.0
3TC03-8DD0	D	2	210 (8.27)	225 (8.86)	179 (7.05)	76 (2.99)	176 (6.93)	-	-	16.1
3TC05-2EE0	E	1	159 (6.26)	178 (7.01)	73 (2.87)	49 (1.93)	113 (4.45)	53 (2.09)	166 (6.54)	3.3
3TC05-4DD0	D	2	210 (8.27)	225 (8.86)	150 (5.91)	76 (2.99)	176 (6.93)	-	-	10.7
3TC06-2FE0	F	2	269 (10.59)	300 (11.81)	220 (8.66)	100 (3.94)	224 (8.82)	-	-	33.9
3TC07-5ED0	E	2	248 (9.76)	270 (10.63)	209 (8.23)	88 (3.46)	200 (7.87)	-	-	24.9
3TC08-0ED0	E	2	210 (8.27)	225 (8.86)	150 (5.91)	76 (2.99)	176 (6.93)	-	-	10.4
3TC08-8FE0	F	2	321 (12.64)	350 (13.78)	288 (11.34)	120 (4.72)	264 (10.39)	-	-	51.5
3TC14-5FD0	F	2	321 (12.64)	350 (13.78)	288 (11.34)	120 (4.72)	264 (10.39)	-	-	51.5
3TC15-4FD0	F	2	210 (8.27)	225 (8.86)	150 (5.91)	76 (2.99)	176 (6.93)	-	-	11.2

1) Mounting slot in center of foot.

Output choke for inverter frame sizes **D**, **E** and **F**

All dimensions are in mm (values in brackets are in inches)

Brake resistors

Figure 1

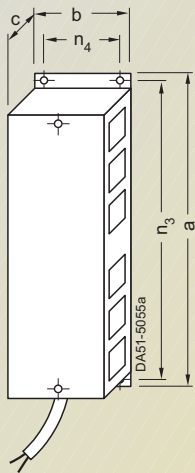

Figure 2

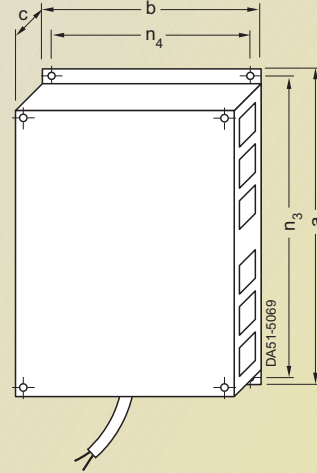
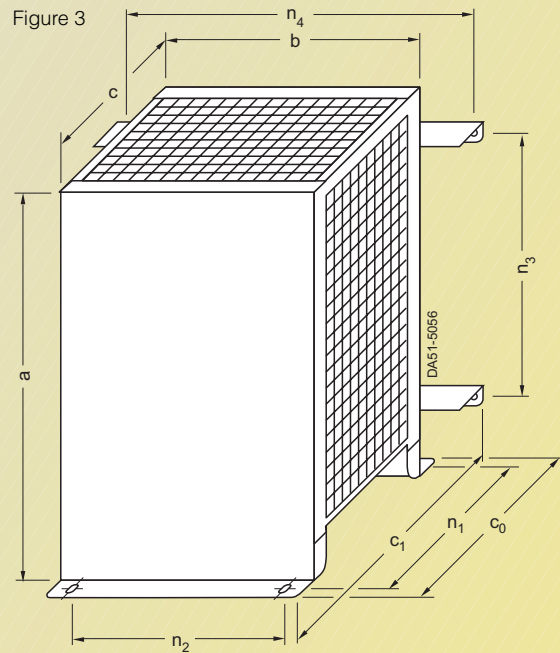

Figure 3



Brake resistor Type 6SE6400-	for inverter frame size (FS)	Fig. No.	Dim.			for console mounting						Weight (max.) kg
			a	b	c	c ₀	c ₁	n ₁	n ₂	n ₃	n ₄	
4BC05-0AA0	A	1	230 (9.06)	72 (2.83)	43.5 (1.71)	-	-	-	-	217 (8.54)	56 (2.20)	1.0
4BC11-2BA0	B	2	239 (9.41)	149 (5.87)	43.5 (1.71)	-	-	-	-	226 (8.90)	138 (5.43)	1.6
4BC12-5CA0	C	3	285 (11.22)	185 (7.28)	150 (5.91)	185 (7.28)	217 (8.54)	170 (6.69)	145 (5.71)	200 (7.87)	230 (9.06)	3.8
4BC13-0CA0	C	3	285 (11.22)	185 (7.28)	150 (5.91)	185 (7.28)	217 (8.54)	170 (6.69)	145 (5.71)	200 (7.87)	230 (9.06)	3.8
4BC18-0DA0	D	3	515 (20.28)	270 (10.63)	175 (6.89)	210 (8.27)	242 (9.53)	195 (7.68)	205 (8.07)	350 (13.78)	315 (12.40)	7.4
4BC21-2EA0	E	3	645 (25.39)	270 (10.63)	175 (6.89)	210 (8.27)	242 (9.53)	195 (7.68)	205 (8.07)	480 (18.90)	315 (12.40)	10.6
4BC22-5FA0	F	3	650 (25.59)	400 (15.75)	315 (12.40)	382 (15.04)	382 (15.04)	335 (13.19)	270 (10.63)	510 (20.08)	435 (17.13)	16.7
4BD11-0AA0	A	1	230 (9.06)	72 (2.83)	43.5 (1.71)	-	-	-	-	217 (8.54)	56 (2.20)	1.0
4BD12-0BA0	B	2	239 (9.41)	149 (5.87)	43.5 (1.71)	-	-	-	-	226 (8.90)	138 (5.43)	1.6
4BD16-5CA0	C	3	285 (11.22)	185 (7.28)	150 (5.91)	185 (7.28)	217 (8.54)	170 (6.69)	145 (5.71)	200 (7.87)	230 (9.06)	3.8
4BD21-2DA0	D	3	515 (20.28)	270 (10.63)	175 (6.89)	210 (8.27)	242 (9.53)	195 (7.68)	205 (8.07)	350 (13.78)	315 (12.40)	7.4
4BD22-2EA0	E	3	645 (25.39)	270 (10.63)	175 (6.89)	210 (8.27)	242 (9.53)	195 (7.68)	205 (8.07)	480 (18.90)	315 (12.40)	10.6
4BD24-0FA0	F	3	650 (25.59)	400 (15.75)	315 (12.40)	382 (15.04)	382 (15.04)	335 (13.19)	270 (10.63)	510 (20.08)	435 (17.13)	16.7
4BE14-5CA0	C	3	285 (11.22)	185 (7.28)	150 (5.91)	185 (7.28)	217 (8.54)	170 (6.69)	145 (5.71)	200 (7.87)	230 (9.06)	3.8
4BE16-5CA0	C	3	285 (11.22)	185 (7.28)	150 (5.91)	185 (7.28)	217 (8.54)	170 (6.69)	145 (5.71)	200 (7.87)	230 (9.06)	3.8
4BE21-3DA0	D	3	515 (20.28)	270 (10.63)	175 (6.89)	210 (8.27)	242 (9.53)	195 (7.68)	205 (8.07)	350 (13.78)	315 (12.40)	7.4
4BE21-8EA0	E	3	645 (25.39)	270 (10.63)	175 (6.89)	210 (8.27)	242 (9.53)	195 (7.68)	205 (8.07)	480 (18.90)	315 (12.40)	10.6
4BE24-2FA0	F	3	650 (25.59)	400 (15.75)	315 (12.40)	382 (15.04)	382 (15.04)	335 (13.19)	270 (10.63)	510 (20.08)	435 (17.13)	16.7

Brake resistors for inverter frame sizes **A** to **F**

All dimensions are in mm (values in brackets are in inches)

Dimension Drawings

Assembly of inverter and options

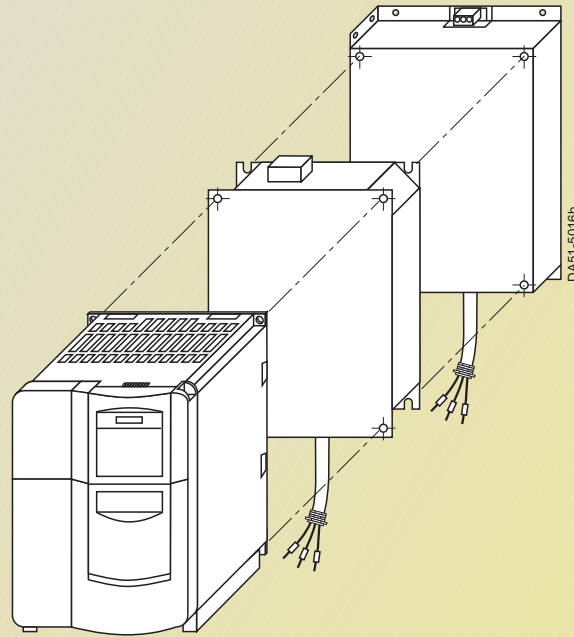

Example:
Assembly of inverter, choke
and filter

If additional accessories
are required, they must be
mounted at the side.

MICROMASTER 410/420/430/440

Appendix

A/2	Environment, Resources and Recycling
A/3	Certificates ISO 9001
A/4	Conformity with Standards
A/6	Demonstration Case
A/7	Training Center Training Courses
A/8	Overview of Motors
A/10	Siemens European Companies and Representatives
A/11	Siemens Companies and Representatives Worldwide
A/13	Online Services
A/14	Service and Support
A/15	Subject Index
A/16	Order No. Index Note for ordering
A/17	Conditions of Sale and Delivery Export Regulations

A

Appendix

Environment, Resources and Recycling

Siemens AG feels a responsibility to play a role in protecting our environment and saving our valuable natural resources. This is true for both our production and our products.

Even during development, we consider any possible environment impact of future products/systems. Our aim is to prevent harmful environment effects, or at least to reduce them to an absolute minimum – beyond present regulations and legislation.

The most important activities for protecting our environment are as follows:

- We are constantly endeavoring to reduce the environmental impact of our products, as well as their consumption of energy and resources, over and above the statutory environmental protection regulations.
- We take every possible step to prevent damage to the environment.
- Environmental impact is assessed and considered at the earliest possible stage of product and process planning.

- Our optimized environmental management strategy ensures that our environment policy is put into practice effectively. The necessary technical and organizational procedures are reviewed at regular intervals and continuously updated.
- An awareness for environmental problems is expected of all our employees. Establishing and furthering a sense of responsibility for the environment on all levels represents a permanent challenge for the corporate management.

- We urge our business partners to act according to the same environmental principles as ourselves. We cooperate with the responsible public authorities.
- We inform interested members of the public about the consequences of our corporate policies for the environment as well as our achievements to the benefit of the environment.
- Our complete documentation is printed on chlorine-free bleached paper.



A

Conformity with Standards

CE Marking



The MICROMASTER inverters comply with the requirements of the low-voltage directive, 73/23/EEC and – with correct installation and selection – with the requirements of the EMC directive 89/336/EEC. A certificate can be provided on request.

The inverters comply with the following standards listed in the EU gazette:

Low-voltage Directive

• EN 60 204

Safety of machinery, electrical equipment of machines

• EN 50 178

Electronic equipment in electrical power installations.

Machine Directive

The inverters are suitable for installation in machines. Compliance with the machine directive 89/392/EEC requires a separate certificate of conformity. This must be furnished by the plant constructor or the installer of the machine.

EMC Directive

• EN 61 800-3

Variable-speed electric drives Part 3: EMC product standard including special test procedure.

The modified EMC product standard EN 61 800-3/A11 for electrical drive systems is valid since 01.01.2002. The following comments apply to the series 6SE6 frequency inverters from Siemens:

- The EMC product standard EN 61 800-3/A11 does not apply directly to a frequency inverter but to a PDS (Power Drive System) which comprises the complete circuitry, motor and cables in addition to the inverter.
- A frequency inverter must therefore only be considered as a component which, on its own, is not subject to the EMC product standard EN 61 800-3/A11. However, the inverter's Instruction Manual specifies the conditions on how the product standard can be complied with if the frequency inverter is completed into a PDS. The EMC directive in the EU is complied with for a PDS by observance of the product standard EN 61 800-3/A11 for PDS. The frequency inverters on their own do not generally require identification according to the EMC directive.
- The frequency inverters as components on their own are only classified as "Limited availability" for persons and users with the necessary EMC knowledge. They are not envisaged for unlimited sale or as "General availability" for users. At this point it is necessary to exactly differentiate between the frequency inverter and the PDS. A PDS can certainly be envisaged by the vendor for general availability, and the standard must be applied accordingly. On the other hand, the components used in the PDS may possibly not be for "General availability".
- Since 01.01.2002, the EMC product standard EN 61 800-3/A11 also defines, for the first time, limits for conducted interference and radiated interference for the so-called "Second environment" (= industrial power supply systems which do not supply households). Although these limits lie below those of filter Class A according to EN 55 011, a PDS with an unfiltered frequency inverter of series 6SE6 nevertheless does not comply with these values, and therefore does not meet the standard EN 61 800-3/A11.
- Using internal or external filters and the installation instructions included in the documentation, the PDS designed using the frequency inverters complies with the product standard EN 61 800-3/A11:
 - Unlimited sale with filters of Class B to EN 55 011 in the first environment (living accommodation and industrial areas)
 - Limited sale and installation by EMC experts with filters of Class A to EN 55 011 in the first environment plus warning information,
 - With filters of Class A to EN 55 011 in the second environment (industrial areas), where these filters even significantly exceed the requirements of EN 61 800-3/A11.

- A differentiation must be made between the product standards for electrical drive systems (PDS) of the range of standards EN 61 800-3/A11 (of which Part 3/A11 covers EMC topics) and the product standards for the devices/systems/machines etc. No changes will probably result in the practical use of frequency inverters. Since frequency inverters are always part of a PDS, and these are part of a machine, the machine vendor must observe various standards depending on the type and environment, e.g. EN 61 000-3-2 for power supply harmonics and EN 55 011 for radio interferences. The product standard for PDS on its own is therefore either insufficient there or irrelevant.

With respect to the compliance of limits for power supply harmonics, the EMC product standard EN 61 800-3/A11 for PDS refers to compliance with the EN 61 000-3-2 and EN 61 000-3-12 standards.

Electromagnetic Compatibility

No impermissible electromagnetic irradiation occurs if the installation guidelines specific to the product are correctly observed.

The table below lists the measured results for emissions of and immunity to interference for MICROMASTER.

The inverters were installed according to the guidelines with shielded motor cables and shielded control cables.

EMC phenomenon Standard/test		Relevant criteria	Limit value
Emitted interference EN 61 800-3 (1st environment ¹⁾)	Conducted via mains cable	150 kHz to 30 MHz	Unfiltered – not tested Internal/external filter: General availability ²⁾ (category C1): limit complies with EN 55 011 Class B (only applies to MICROMASTER 410) Limited availability ³⁾ (category C2): limit complies with EN 55 011, Class A, Group 1
	Emitted by the drive	30 MHz to 1 GHz	All devices: Limited availability ³⁾ : limit complies with EN 55 011 Group 1, Class A
ESD immunity EN 61 000-4-2 ESD through air discharge ESD through contact discharge		Test level 3	8 kV
		Test level 3	6 kV
Electrical fields immunity EN 61 000-4-3 Electrical field applied to unit		Test level 3	10 V/m
		26 MHz to 1 GHz	
Burst interference immunity EN 61 000-4-4 Applied to all cable terminations		Test level 4	4 kV
Surge immunity EN 61 000-4-5 Applied to mains cables		Test level 3	2 kV
Immunity to RFI emissions, conducted EN 61 000-4-6 Applied to mains, motor and control cables		Test level 4	10 V
		0.15 MHz to 80 MHz 80 % AM (1 kHz)	

UL Listing



® and c®- listed power conversion equipment type 5B33 in accordance with UL508C.
For use in pollution degree 2 environment.

1) 1st environment

(living accommodation, business and industrial areas): environment which includes living accommodation and also equipment which is directly connected to a low-voltage power supply system without intermediate transformers, where this system also supplies living accommodation.

2) General availability

Sales channel where installation is independent of the customer's or user's EMC knowledge.

Category C1:

Power Drive System (PDS) with rated voltage < 1000 V.
For use in 1st environment.

3) Limited availability:

Sales channel where installation is limited to dealers, customers or users who – either individually or together – have technical EMC knowledge.

Category C2:

Power Drive System (PDS) with rated voltage < 1000 V.
When used in 1st environment, installation and start-up only by EMC experts.

Appendix

Demonstration Case

With the MICROMASTER 420 and 440 demonstration case, one of these inverters can be selected using a switch.

The inverters are equipped with status display panels (SDP). A BOP, AOP or other options must be ordered separately.

The demonstration case has the following features:

- 2 inverters (MICROMASTER 420 and MICROMASTER 440)
- Asynchronous motor 1LA7 from Siemens
- Precise, mechanical brake for demonstration of torque control
- Double voltage range (90 V to 130 V and 190 V to 265 V)
- Extremely rugged metal case, particularly suitable for traveling.



Demonstration case	Order No.	Weight, approx. kg
MICROMASTER 420 and 440	6SE6400-0DC40-0AA0	15

SIDEMO Demonstration Case System

The SIDEMO range of modular demonstration case systems also includes cases for the MICROMASTER inverters.

The MICROMASTER demonstration cases can be operated on their own or together with other demonstration systems such as e.g. LOGO!, SIMATIC S7-200, SITOP DC-UPS.

The demonstration systems are fitted in dark blue transport cases (400 x 300 x 210 mm) which can be stacked.

When expanding the MICROMASTER 420/440 demonstration case by a PROFIBUS module (not included in delivery of case), it is also possible to demonstrate the incorporation into TIA when using the SIMATIC S7-300 Compact and Touch Panel TP170B demonstration systems.



SIDEMO demonstration case	Order No.	Weight, approx. kg
MICROMASTER 410 • including OP operator panel	6AG1062-1AA08-0AA0	10
MICROMASTER 420 • including BOP operator panel	6AG1062-1AA02-0AA0	10
MICROMASTER 440 • including BOP operator panel	6AG1062-1AA02-1AA1	10
MICROMASTER 440 • including BOP operator panel • the motor is equipped with a load unit	6AG1062-1AA06-0AA0	10
MICROMASTER 440 • including BOP operator panel and pulse encoder evaluation module • the motor is equipped with an encoder and a load unit	6AG1062-1AA07-0AA0	10

Further information available on the Internet at: <http://www.siemens.com/sidemo>

Training Center

Siemens A&D Training Centers are located worldwide, and offer the courses listed below for MICROMASTER. Individual course contents, or training on site at customers, can also be carried out.

Contact partner:

Every A&D Information and Training Center in the regions and the regional companies in Germany:
Tel.: +49 (0) 911-895 32 02

Headquarters:

Siemens AG
Automation and Drives
Training Center
P.O. Box 48 48
D-90327 Nuremberg
Germany

E-mail:

A&D.Kursbuero@nbgm.
siemens.de

Phone:

+49 (0) 9 11-8 95-32 00

Fax:

+49 (0) 9 11-8 95-32 75



Training Courses

MICROMASTER 4 servicing, commissioning

SD-MM4 (2 days)

This course is aimed at commissioning and servicing engineers for the MICROMASTER 4 drives. It covers proper utilization of the MICROMASTER 440 inverter functionality, as well as that of the MICROMASTER 420 inverter. This course is also suitable for beginners, since it can be adapted to provide more in-depth knowledge if required.

Course targets/contents:

- Fundamentals of asynchronous motors
- Fundamentals of inverters
- Programming using BOP, AOP
- PC programs: DriveMonitor/STARTER
- Commissioning using V/f characteristic and vector control
- Optional programming of input and output terminals

- Use of special functions such as flying restart, DC brakes
- Warnings and fault signals
- Practical exercises using the field-proven demonstration cases.

MICROMASTER 4 communication

SD-MM4-COM (2 days)

This course is aimed at commissioning and servicing engineers working with the MICROMASTER 4 on the PROFIBUS-DP. Knowledge of MICROMASTER and SIMATIC S7 are prerequisites.

It imparts knowledge on the concept of Totally Integrated Automation (TIA).

Course targets/contents:

- Fundamentals of PROFIBUS-DP with emphasis on drive technology
- Design of the PROFIBUS-DP bus system
- Configuration of a PROFIBUS-DP network in Step 7

- Commissioning of the MICROMASTER inverter on the PROFIBUS-DP
- Transmission of process data and parameter values (protocol, PNO profile)
- PROFIBUS-DP with Motion Control expansion (lateral communication, equidistance, clock synchronization)
- Block library
- Drive ES SIMATIC
- Fault diagnostics of the drive via the bus system
- Practical exercises on the MICROMASTER 440 demonstration cases and the SIMATIC S7 demonstration cases with CPU 315-2 DP.

Tip:

The course sometimes directly follows the SD-MM4 course. Participants need then only travel once.

Note:

This course handles the DriveES SIMATIC block library. The SD-MD-COM course provides comprehensive information on alternatives such as loading/transfer commands, system functions, DVA-S7 blocks.

Computer based Training (CBT) and Web based Training (WBT)

Commissioning is carried out in interactive mode using the MICROMASTER 420 frequency inverter. In particular, handling of the parameter keyboard is practically identical to the original. The training time is 3 to 4 hours depending on the level of knowledge.

Contents:

- Asynchronous motors connected to power supply and inverter
- Overview of MICROMASTER inverter
- Electrical installation
- Parameter input, structure of parameter set
- Rating plate of motor
- Simple commissioning
- Assignment of different functions to the terminals.

You can find further information in the Catalog ITC or at <http://www.sitrain.com>.



Appendix

Overview of Motors

Siemens motors are an ideal supplement to the MICROMASTER inverters.

The table provides an overview of the most common types of motors from Siemens.

In addition to the motors listed in the table, explosion-proof motors, marine motors and combustion gas motors are also available.

Catalogs M 11 and M 15 contain the complete range of products with ordering data, technical details and explanations.

Motors with gray cast iron casing

Efficiency class	EFF I ^{*)}	EPACT	EFF 2 ^{*)}		
	1LG6	1LA6 ^{**)}	1LA6	1LG4	1LA8
Motor type	18.5-200 kW	50-200 hp	2.2-15 kW	18.5-200 kW	250-1000 kW
Rating (4-pole)	Speed rpm	Speed rpm	Speed rpm		
Speed/torque	3000 1500 1000 750	3600 1800 1200	3000 1500 1000 750		
Voltage (at 50 Hz if not specified otherwise)	230/400 V Δ /Y 400/690 V Δ /Y	60 Hz 460 V Δ	230/400 V Δ /Y 400/690 V Δ /Y		400/690 V Δ /Y
Size	180-315	225-315	100-160	180-315	315-450
Design	IM B3 IM B5 IM V1 IM B14 (sizes 100 to 160) IM B35				IM B3 IM V1 IM B35
Casing	Gray cast iron				
Degree of protection	IP 55 (IP 65, IP 56)				IP 55 (IP 56)

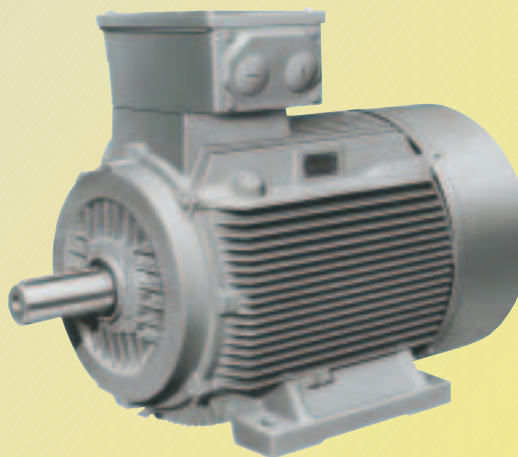

Example of 1LA6 motor

^{*)} 1.1 kW to 90 kW, 2-pole and 4-pole

^{**)} Successor type 1LG6

Motors with aluminium casing

Gear motors

EFF 1 *)	EPACT	EFF 2 *)		Spur gear	Flat gear	Bevel gear	Spur worm gear
1LA9	1LA9	1LA7	1LA5	2KG11	2KG12	2KG13	2KG14
0.06-30 kW	0.08-40 hp	0.06-15 kW	18.5-45 kW	0.09-7.5 kW			0.12-7.5 kW
Speed rpm	Speed rpm	Speed rpm		Torque Nm	Torque Nm	Torque Nm	Torque Nm
3000 1500 1000	3600 1800 1200	3000 1500 1000 750		80-550	130-660	120-800	70-1400
230/400 V Δ /Y 400/690 V Δ /Y	60 Hz 460 V Δ	230/400 V Δ /Y 400/690 V Δ /Y		230/400 V Δ /Y; 500 V Y 400/690 V Δ /Y			
56-200		56-160	180-225	63-132			
IM B3 IM B5 IM V1 IM B14 (sizes 56 to 160) IM B35				Foot-mounting type Flange-mounting type Universal mounting type			
Aluminium				Chilled casting	Aluminium	Aluminium or gray cast iron	
IP 55 (IP 65, IP 56)				IP 55 (IP 65, IP 56)			

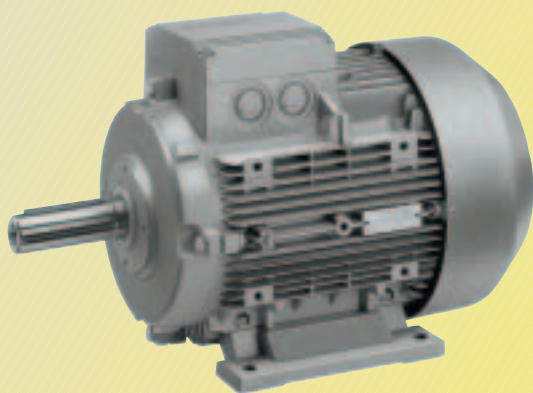

Example of motor 1LA7

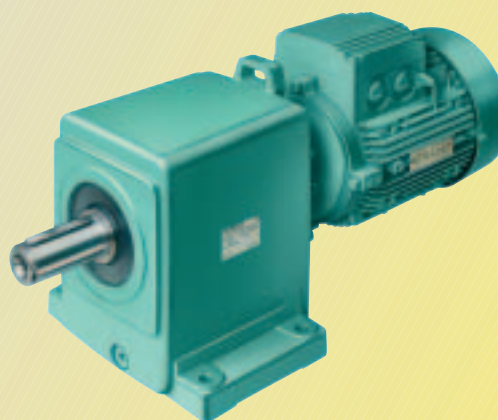

Example of spur gear motor 2KG11

*) 1.1 kW to 90 kW, 2-pole and 4-pole

A

Appendix

Siemens European Companies and Representatives

Albania

BINDI sh. p. k.
Tirana

Armenia

Representative of Siemens AG
Yerevan

Austria

Siemens AG Österreich

Vienna
Bregenz
Deutschlandsberg
Eisenstadt
Graz
Innsbruck
Klagenfurt
Klosterneuburg
Linz
Salzburg
St. Pölten
Villach

Azerbaijan

Representative of SIMKO AS
Baku

Belarus

Representative of Siemens AG
Minsk

Belgium

Siemens S. A.

Brussels
Antwerpen
Boussu
Colfontaine
Dilsen-Stokkem
Gent
Haasrode
Herentals
Huizingen
Liège
Namur
Oostkamp
Zaventem

Bosnia-Herzegovina

Siemens d.o.o.
Sarajevo

Bulgaria

Siemens AG Representative in Bulgaria
Sofia

Croatia

Siemens d.d.
Zagreb

Cyprus

GEVO Ltd.
Nicosia

Czech Republic

Siemens s.r.o.

Prague
Brno
Děčín
Stříbro
Trutnov

Denmark

Siemens A/S

Ballerup
Alborg
Brønshøj
Esbjerg
Hedensted
Højbjerg
Odense
Skensved
Tåstrup
Vejele

Eire (Ireland)

Siemens Ltd.
Dublin

Estonia

AS Siemens
Tallinn

Finland

Siemens
Osakeyhtiö
Espoo
Helsinki

France

Siemens S. A. S.

Saint-Denis
Bihorel
Caluire-et-Cuire
Cesson Sévigné
Dijon
Haguenau
La Garenne Colombes
La-Suze-sur-Sarthe
Lesquin
Les Ulis
Lissess
Lormont
Marseille
Mérignac
Metz
Montrouge
Molsheim
Nanterre
Nantes
Nice
Pantin
Paris La Défense
Reims
Saint-Denis
Saint-Quentin
Strasbourg
Toulouse

Georgia

Representative of Siemens AG
Tbilisi

Great Britain and Northern Ireland

Siemens plc

Bracknell
Beeston
Belfast
Bellshill
Birmingham
Bristol
Camberley
Cambridge
Chessington
Christchurch
Clevedon
Corby
Congleton
Crawley
Cumbernauld
East Kilbride
Fareham
Glasgow
Hemel Hempstead
Hounslow
Ilford
Isle of Wight
London
Luton
Manchester
Milton Keynes
Newcastle-upon-Tyne
Oldham
Oxford
Poole
Purley
Romsey
Telford
Wellingborough
Wembley

Greece

Siemens A. E.

Athen, Amaroussio
Acharnes
Thessaloniki
Vassilikos Evias

Hungary

Siemens Rt.

Budapest
Bicske
Cegléd
Szombathely

Iceland

Smith & Nordland HF
Reykjavik

Italy

Siemens S. p. A.

Milano
Bari
Bologna
Brescia
Cagliari
Casoria
Cassina de Pecchi
Fanglia
Firenze
Genova
Napoli
Padova
Palermo
Pescara
Roma
Torino
Verona

Latvia

Siemens S/A
Riga

Lithuania

Lietuvos ELTIKA
Vilnius
Klaipeda

Luxembourg

Siemens S. A.
Luxembourg-Hamm

Macedonia

SITAI d.o.o.
Skopje

Malta

J.R.D. SYSTEMS Ltd.
Harun

Moldavia

Siemens s.r.l.
Chisinau

Netherlands

Siemens Nederland N. V.
Den Haag
Alphen a/d Rijn
Zoetermeer

Norway

Siemens A/S

Oslo
Fyllingsdalen
Trondheim

Poland

Siemens Sp.z.o.o.

Warsaw
Gdańsk-Wrzeszcz
Katowice
Kratów
Poznań
Wrocław

Portugal

Siemens S. A.

Lisbon
Amadora
Albufeira
Carnaxide
Coimbra
Evora
Loures
Matosinhos Codex
Mem Martins
Seixal

Romania

Siemens birou de consultații tehnice

Bucharest
Slatina

Russia

Siemens GmbH Moskau

Moscow
Barnaul
Jakutsk
Yekaterinburg
Irkutsk
Yshewsk
Kaluga
Krasnodar
Novosibirsk
Perm
St. Petersburg
Tbilissi
Tjumen
Tomsk
Ufa
Vladivostok

Slovak Republic

Siemens s.r.o.

Bratislava
Dolný Kubín
Horná Streda
Michalovce
Nitra
Nové Zámky
Trnava

Slovenia

Siemens d.o.o.

Ljubljana
Kranj
Maribor

Spain

Siemens S. A.

Bilbao
Cornellá de Llobregat
Gijón
La Coruña
Las Palmas de Gran Canaria
León
Málaga
Murcia
Palma de Mallorca
Santa Cruz de Tenerife
Sevilla
Tres Cantos (Madrid)
Valencia
Valladolid
Vigo
Zaragoza

Sweden

Siemens AB

Upplands Väsby
Göteborg
Haninge
Jönköping
Kista
Malmö
Solna
Sundsvall

Switzerland

Siemens Schweiz AG

Zürich
Adliswil
Basel
Bioggio
Bronschhofen
Dietikon-Fahrweid
Fahrweid
Winterthur-Töss

Turkey

SIMKO Ticaret ve Sanayi A.S.

Findikli Istanbul
Adana
Alsancak-Izmir
Ayazag-Istanbul
Beşiktaş-Istanbul
Bursa
Cerkezköy-Tekirdag
Kartal-Istanbul
Kavaklıdere-Ankara
Mecidiyeköy-Istanbul
Mudanya
Samsun

Ukraine

Representative of Siemens AG

Kiev
Charkiv
Odessa
Wischgorod

Yugoslavia

Siemens d.o.o.

Beograd

Siemens Companies and Representatives Worldwide

Africa

Algeria

Siemens Bureau d'Alger
Hydra

Angola

Escritório de Representação da Siemens em Angola
Luanda

Botswana

Siemens (Pty) Ltd.
Gaborone
Iwaneng

Congo

SOFAMATEL S.P.R.L.
Kinshasa

Côte d'Ivoire

Siemens AG
S.A.R.L.
Abidjan

Egypt

Siemens Limited
Cairo-Mohandessin
Smouha Alexandria
Centech
Cairo-Zamalek

Ethiopia

Siemens (Pvt)
Addis Abeba

Ghana

Impromex ACCRA
Accra

Guinea

André & Cie. S. A.
Lausanne

Kenya

Siemens Communications Ltd.
Nairobi

Lesotho

Range Telecommunication Systems (Pty) Ltd
Maseru

Libya

Siemens A. G. Branch Libya
Tripoli

Malawi

Ecoelectric Ltd.
Blantyre

Mauritius

Ireland Blyth Ltd
Port Louis

Morocco

SETEL
Société Electrotechnique
et de Télécommunication S. A.
Casablanca

Mosambique

Siemens Limitada
Maputo

Namibia

Siemens (Pty.) Ltd.
Windhoek

Nigeria

Siemens Limited
Lagos
Abuja
Kaduna

Republic of South Africa

Siemens Ltd.
Halfway House
Centurion
Isando
Pretoria
Springs
Woodmead

Sudan

National Electrical
Commercial Co.
Khartoum

Swaziland

Siemens (Pty) Ltd
Matsapha

Tanzania

Tanzania Electrical Services Ltd.
Dar-es-Salaam

Tunesia

Siemens Bureau de Liaison
Tunis

Zambia

Siemens (Z) Ltd.
Kitwe
Lusaka

Zimbabwe

Siemens (Pvt.) Ltd.
Harare
Alexandra Park

America

Argentina

Siemens S. A.
Buenos Aires
San Martin
Bahia Blanca
Córdoba
Las Heras
Mar del Plata
Rosario
Boulogne sur Mer

Bolivia

Sociedad Comercial é Industrial Hansa Ltda.
La Paz

Brazil

Siemens Ltda.
Sao Paulo
Belo Horizonte
Brasilia
Campinas
Curitiba
Florianópolis
Fortaleza
Fravatai
Jaboatao dos Guararapes
Jundiai
Manaus
Porto Alegre
Ribeirao Preto
Rio de Janeiro
Salto
Salvador
S. Bernardo do Campo
Vila Sao Joao

Canada

Siemens Canada Limited
Mississauga
Ajax
Brampton
Burnaby
Calgary
Cambridge
Clatham
Dartmouth
Drummondville
Edmonton
Kanata
London
Moncton
Montreal
Mount Pearl
Ottawa
Pointe Claire
Sackatoon
Sherbrooke
Tilbury
Vanier
Windsor
Winnipeg

Chile

Siemens S.A.
Santiago de Chile

Colombia

Siemens S. A.
Santafé de Bogotá
Barranquilla
Cali-Occidente
Medellin

Costa Rica

Siemens S. A.
San José

Cuba

EUMEDA
Representación Consultiva de Siemens
Electromedicina
Ciudad de la Habana

Curaçao

SANTRACO N. V.
Willemstad

Dominican Republic

Electromédica S. A.
Santo Domingo

Ecuador

Siemens S. A.
Quito
Guayaquil

El Salvador

Siemens S. A.
San Salvador

Guatemala

Siemens S. A.
Ciudad de Guatemala

Honduras

Representaciones Electroindustriales
S. de R.L.
San Pedro Sula
Tegucigalpa

Jamaica

Meditron Ltd.
Kingston

Martinique

Périé Medical
Fort-de-France

Mexico

Siemens S A de CV
México, D.F.
Aguascalientes
Apodaca
Chihuahua
Cd. Juárez
Culiacán
Gómez Palacio
Hermosillo
León
Mérida
Puebla
San Juan Cuautlancingo
Tijuana
Tlajomulco de Zuniga
Veracruz
Villa Corregidora

Nicaragua

Siemens S. A.
Managua

Panama

Siemens S. A.
Panama

Paraguay

Rieder & Cia. S. A. C. I.
Asunción

Peru

Siemens S. A.
Lima

Trinidad and Tobago

Biomedical Technologies Ltd.
St. Augustin

United States of America

Siemens Corporation
New York
Allentown
Alpharetta
Arlington
Atlanta
Auburn Hills
Boca Raton
Bridgewater
Brooklyn Park
Camarillo
Charlotte
Columbus
Concord
Cupertino
Danvers
Duluth
Fountain Inn
Gainsville
Hickory
Hoffman Estates
Issaquah
Iselin
Johnson City
Lake Oswego
Lima
Milwaukee
Newport News
Norcross
Oklahoma City
Palo Alto
Piscataway
Princeton
Richardson
Richland
Sacramento
Santa Clara
Santa Fe Springs
San Jose
Sunnyvale
Totawa
Washington
Wendell

Uruguay

Conatel S.A.
Montevideo

Venezuela

Siemens S. A.
Caracas
Barcelona
Maracaibo
Perto Ordaz
Valencia

Appendix

Siemens Companies and Representatives Worldwide

Asia

Bahrain

Siemens AG Service Center
Transitec Gulf
Manama

Bangladesh

Siemens Bangladesh Ltd.
Dhaka
Dhulna

Brunei

AMS Technologies
Sdn Bhd
Negara
Brunei
Darussalam

India

Siemens Ltd.
Ahmedabad
Bangalore
Calcutta
Chandigarh
Chennai
Coimbatore
Gurgaon
Kaloor
Mumbai
Nashik
Navi Mumbai
New Dehli
Pune
Secunderabad
Vadodara

Indonesia

Representative Office Siemens AG
Jakarta
Batam
Cilegon
Surabaya

Iraq

Siemens AG
Baghdad

Iran

Siemens S.S.K.
Teheran

Israel

Siemens Ltd.
Tel Aviv
Holon
Herzeliya
Ramat Hakhaiyal

Japan

Siemens K. K.
Tokyo
Kobe
Fukuoka
Hiroshima
Ishikawa
Kanagawa
Nagoya
Osaka
Sapporo
Sendai
Yokohama

Jordan

Siemens AG
Jordan Branch
Shmeisani-Amman
Amman

Kazakhstan

Representative of Siemens AG
Almaty

Kirghizstan

Representative of Siemens AG
Bischkek

Korea (Republic)

Siemens Ltd.
Seoul
Changwon
Kyungki-Do

Kuwait

National & German Electrical and
Electronic Services Co.
(NGEECO)
Kuwait

Lebanon

Siemens AG Lebanon Branch
Beyrouth

Malaysia

Siemens Electrical
Engineering Sdn. Bhd.
Petaling Jaya
Kuala Lumpur
Kajang

Myanmar

Siemens Ltd.
Yangon

Nepal

Amatya Enterprises (Pvt.) Ltd.
Kathmandu

Oman

Siemens AG
Muscat Branch
Ruwi
Muscat

Pakistan

Siemens Pakistan
Engineering Co. Ltd.
Karachi
Faisalabad
Islamabad
Lahore
Peshawar
Quetta

People's Republic of China

Siemens Ltd., China
Beijing
Changchun
Chengdu
Chongqing
Chuzhou
Dalian
Fuqing
Fuzhou
Guangzhou
Hangzhou
Jilin
Jinan
Nanghai
Nanjing
Panyu
Rizhao
Shanghai
Shenyang
Shenzhen
Suzhou
Tianjin
Wuhan
Wuxi
Xi'an
Xiaogan City
Zibo

Philippines

Siemens Inc.
Makati City
Pasig City
Cebu
Davao City

Qatar

Arabian Construction
Engineering Company
Doha

Saudi Arabia

Arabia Electric Ltd. (Equipment)
Jeddah
Al Khobar
Riyadh

Singapore

Siemens Advanced Engineering (Pte.) Ltd.
Singapore

Sri Lanka

Dimo Limited
Colombo

Syria

Siemens AG
Damascus Branch
Damascus

Taiwan

Siemens Ltd.
Taipei
Taichung
Kaohsiung
Taoyuan Hsien

Thailand

Siemens Limited
Bangkok
Rayong

Turkmenistan

Representative of Siemens AG
Aschgabad

Uzbekistan

Representative of Siemens AG
Taschkent

United Arab Emirates

Siemens Resident Engineers
Dubai
Abu Dhabi

Vietnam

Siemens AG Representation
Hanoi
Ho Chi Minh City

Yemen

Tihama Tractors & Engineering Co. Ltd.
Sanaa
Aden

Australia

Siemens Ltd.
Melbourne
Adelaide
Bayswater
Brisbane
Gladsville
Milton
Pennant Hills
Perth
Silverwater
St. Leonards
Sydney

New Zealand

Siemens (NZ) Limited
Auckland
Wellington

A&D in the WWW



A detailed knowledge of the range of products and services available is essential when planning and configuring automation systems. It goes without saying that this information must always be fully up-to-date.

The Siemens Automation and Drives Group (A&D) has therefore built up a comprehensive range of information in the World Wide Web, which offers quick and easy access to all data required.

Under the address

<http://www.siemens.com/automation>

you will find everything you need to know about products, systems and services.

Product Selection Using the Interactive Catalogs



Detailed information together with convenient interactive functions:

The interactive catalogs CA 01 and ET 01 cover more than 80,000 products and thus provide a full summary of the Siemens Automation and Drives product base.

Here you will find everything that you need to solve tasks in the fields of automation, switchgear, installation and drives.

All information is linked into a user interface which is easy to work with and intuitive.

After selecting the product of your choice you can order at the press of a button, by fax or by online link.

Information on the interactive catalogs can be found in the Internet under

<http://www.siemens.com/automation/ca01>

or on CD-ROM.

Automation and Drives, CA 01
Order No.:
E86060-D4001-A110-B7-7600

Electrical installation technology, ET 01
Order No.:
E86060-D8200-A107-A3-7600

Easy Shopping with the A&D Mall



The A&D Mall is the virtual department store of Siemens AG in the Internet. Here you have access to a huge range of products presented in electronic catalogs in an informative and attractive way.

Data transfer via EDIFACT allows the whole procedure from selection through ordering to tracking of the order to be carried out online via the Internet.

Numerous functions are available to support you.

For example, powerful search functions make it easy to find the required products, which can be immediately checked for availability. Customer-specific discounts and preparation of quotes can be carried out online as well as order tracking and tracing.

Please visit the A&D Mall on the Internet under:

<http://www.siemens.com/automation/mall>



Appendix

Customer Support Automation and Drives



Whether you need a service expert or a spare part, a product specialist for advice, or if you just have a query, then the Customer Support is the address for you – the team that meets all your needs!

Helpline for Service and Support



You need help but do not know who to address. We take care that help is on the way quickly.

The helplines ensure that the right specialist in your vicinity will be of skilled assistance to you. The Helpline e. g. for Germany helps in German and English 24 hours/day, 365 days/year.

Tel.: 0180 50 50 111

Online Support



Our Online Support guarantees quick and efficient assistance – around the clock, worldwide and in five languages.

The Online Support offers all technical information:

- FAQs, tips & tricks, downloads and news
- Free manuals
- Useful programs and software

<http://www.siemens.com/automation/service&support>

Field Service



Your system is installed and now you need quick on-site help. We have the specialists with the know-how you require, worldwide and at hand.

Thanks to our comprehensive service network, we are able to realize short response times – with competence, reliability, and speed.

You can request an expert in Germany 24 hours/day and 365 days/year.

Tel.: 0180 50 50 444

Of course we offer also service contracts customized to your requirements. Your Siemens Office is always at your disposal.

Spare Parts and Repairs



Our worldwide network of local spare parts stocks and repair centers react with speed and reliable logistics.

For requests about repairs or spare parts please call the following telephone number (in Germany):

Tel.: 0180 50 50 446

Outside the office hours and on weekends, dial this number for our spare parts stand-by service.

Technical Support



Technical advice for implementation of products, systems and solutions in automation and drive technology is provided in German and English.

- Competent, qualified and experienced specialists offer teleservice and video conferencing for specific problems.
- FreeContact – the way to the free Technical Support.
- in Europe (headquarter)
Tel.: +49 (0)180 50 50 222
Fax: +49 (0)180 50 50 223
E-mail: techsupport@ad.siemens.de

- in the United States
Tel.: +1 423 461-2522
Fax: +1 423 461 2231
E-mail: simatic.hotline@sea.siemens.com
- in Asia
Tel.: +65 740-7000
Fax: +65 740 7001
E-mail: simatic@singnet.com.sg

Our network of dependencies in Germany, the U.S. and Singapore offers support around the clock according to the “follow the sun” principle via FastContact – the fast way to the Technical Support:

- Return call within two hours guaranteed
 - around the clock
 - payment with SIMATIC card
- Tel.: +49 (0)911 895 7777**
Fax: +49 (0)911 895 7001

Subject Index

MICROMASTER

	410	420	430	440
	Page	Page	Page	Page
A				
AOP (advanced operator panel)	-	2/14	-	4/19
Applications	1/2	2/2	3/2	4/2
Assignment table for options	0/4	0/4	0/4	0/4
B				
BOP (basic operator panel)	-	2/14	-	4/19
BOP-2 (basic operator panel)	-	-	3/12	-
Brake resistor (option)	-	-	-	4/15
C				
CE marking	A/4	A/4	A/4	A/4
Chokes (option)	1/9	2/12	3/10	4/15
Circuit breaker (option)	1/9	2/13	3/10	4/16
Circuit diagrams	1/4	2/4	3/4	4/4
Communications modules	-	2/14	3/12	4/19
Conditions of sale and delivery	A/17	A/17	A/17	A/17
Conformity with standards	A/4	A/4	A/4	A/4
D				
Demonstration case	A/6	A/6	A/6	A/6
Derating data	1/6	2/7	3/7	4/7
Description (inverter)	1/2	2/2	3/2	4/2
Description (options)	1/8	2/9	3/9	4/12
Design	1/2	2/2	3/2	4/2
DeviceNet module (option)	-	2/14	3/12	4/19
Dimension drawings	1/10	2/16	3/14	4/21
Documentation	1/9	2/15	3/13	4/20
Docu-Pack	-	2/15	3/13	4/20
DriveMonitor	1/9	2/10	3/9	4/13
E				
Electromagnetic compatibility	A/4	A/4	A/4	A/4
EMC filter (option)	1/9	2/11	3/11	4/14
Environment, resources and recycling	A/2	A/2	A/2	A/2
Export regulations	A/17	A/17	A/17	A/17
F				
Features	1/3	2/3	3/3	4/3
Filter (option)	1/9	2/11	3/11	4/14
Fuses (option)	1/9	2/13	3/10	4/16
G				
General circuit diagram	1/4	2/4	3/4	4/4
Getting Started Guide	1/9	2/15	3/13	4/20
Gland plates (option)	-	2/13	3/10	4/16
I				
Installation height (derating)	1/7	2/7	3/7	4/8
International standards	1/2	2/2	3/2	4/2
Internet (online services)	A/13	A/13	A/13	A/13
ISO 9001 certificate	A/3	A/3	A/3	A/3
L				
Line commutating chokes (option)	1/9	2/12	3/10	4/15

MICROMASTER

	410	420	430	440
	Page	Page	Page	Page
M				
Main characteristics	1/2	2/2	3/2	4/2
Mechanical features	1/3	2/3	3/3	4/3
N				
Note for ordering	A/16	A/16	A/16	A/16
O				
OP (operator panel)	1/9	-	-	-
Operating instructions	1/9	2/15	3/13	4/20
Operating temperature (derating)	-	2/7	3/7	4/8
Operator panels	1/9	2/14	3/12	4/19
Options	1/8	2/9	3/9	4/12
Ordering data (inverter)	1/7	2/8	3/8	4/9
Ordering data (options)	1/9	2/11	3/10	4/14
Output chokes (option)	-	2/12	3/10	4/15
Overview	0/2	0/2	0/3	0/3
Overview of motors	A/8	A/8	A/8	A/8
P				
Parameter list	1/9	2/15	3/13	4/20
Performance features	1/3	2/3	3/3	4/3
PROFIBUS module (option)	-	2/14	3/12	4/19
Protection features	1/3	2/3	3/3	4/3
Pulse encoder evaluation module (option)	-	-	-	4/19
Pulse frequency (derating)	1/6	2/7	3/7	4/7
S				
Sales regions	A/10	A/10	A/10	A/10
Selection aid	0/2	0/2	0/3	0/3
Selection and ordering data (inverter)	1/7	2/8	3/8	4/9
Selection and ordering data (options)	1/9	2/11	3/10	4/14
Service and support	A/14	A/14	A/14	A/14
SIDEMO (demonstration case system)	A/6	A/6	A/6	A/6
STARTER	1/9	2/10	3/9	4/13
Start-up software	1/9	2/10	3/9	4/13
Support	A/14	A/14	A/14	A/14
T				
Technical data (inverter)	1/6	2/6	3/6	4/6
Technical data (options)	-	2/14	3/12	4/19
Terminal connection diagram	1/5	2/5	3/5	4/5
Training center	A/7	A/7	A/7	A/7
Training courses	A/7	A/7	A/7	A/7
U				
UL certification	A/5	A/5	A/5	A/5
V				
Variant dependent options	1/9	2/11	3/10	4/14
Variant independent options	1/9	2/14	3/12	4/19

MICROMASTER 410/420/430/440

Appendix

Order No. Index

MICROMASTER

	410	420	430	440
	Page	Page	Page	Page
3NA3...	1/9	2/13	3/10, 3/11	4/16, 4/18
3NE1...	-	-	3/10, 3/11	4/16, 4/18
3RV10..	1/9	2/13	3/10, 3/11	4/16, 4/18
3VL....	-	-	3/10, 3/11	4/16, 4/18
6GK1500-0FC00	-	2/14	3/12	4/19
6SE6400-0AP00-0AA1	-	2/14	-	4/19
6SE6400-0BE00-0AA0	-	-	3/12	-
6SE6400-0BP00-0AA0	-	2/14	-	4/19
6SE6400-0DN00-0AA0	-	2/14	3/12	4/19
6SE6400-0DR00-0AA0	1/9	-	-	-
6SE6400-0EN00-0AA0	-	-	-	4/19
6SE6400-0GP00-0.A0	-	2/13	3/10	4/16, 4/17
6SE6400-0MD00-0AA0	-	2/14	-	4/19
6SE6400-0P.00-0AA0	1/9	2/14	3/12	4/19
6SE6400-0SP00-0AA0	1/9	-	-	-
6SE6400-1P.00-0AA0	-	2/14	3/12	4/19
6SE6400-2FA0.	-	2/11	-	4/14
6SE6400-2FB0.	-	2/11	-	4/14
6SE6400-2FL0.	1/9	2/12	-	4/14
6SE6400-2FS0.	-	2/11	3/11	4/17
6SE6400-3CC..	1/9	2/12	3/10, 3/11	4/15, 4/17
6SE6400-3TC..	-	2/12	3/10, 3/11	4/15, 4/17
6SE6400-4B...	-	-	-	4/15, 4/17
6SE6400-5....	1/9	2/15	3/13	4/20
6SE6410-2BB..	1/7	-	-	-
6SE6410-2UA..	1/7	-	-	-
6SE6410-2UB..	1/7	-	-	-
6SE6420-2AB..	-	2/8	-	-
6SE6420-2AC..	-	2/8	-	-
6SE6420-2AD..	-	2/8	-	-
6SE6420-2UC..	-	2/8	-	-
6SE6420-2UD..	-	2/8	-	-
6SE6430-2AD..	-	-	3/8	-
6SE6430-2UD..	-	-	3/8	-
6SE6440-2AB..	-	-	-	4/11
6SE6440-2AC..	-	-	-	4/11
6SE6440-2AD..	-	-	-	4/11
6SE6440-2UC..	-	-	-	4/9
6SE6440-2UD..	-	-	-	4/9
6SE6440-2UE..	-	-	-	4/10
6SL3000-0BE3.	-	-	-	4/14
6SL3000-0CE3.	-	-	-	4/15

Note for ordering

Release versions/designs

The last digit of the complete Order No. for the inverters represents the release version.

When ordering, a digit from that specified may be present as a result of further technical development.

A

Conditions of Sale and Delivery

In Germany

Subject to the General Conditions of Sale as well as the General Conditions of Supply and Delivery for Products and Services of the Electrical and Electronics Industry.

For Export

Subject to the General Conditions of Supply and Delivery for Products and Services of the Electrical and Electronics Industry and to any other conditions agreed upon with the recipients of catalogs/price lists.

■ Software products are subject to the General Licence Conditions for Software Products for Automation and Drives.

Prices are listed in € (Euro) ex delivery point, excluding packaging.

Turnover tax (VAT) is not included in the prices. It will be added according to legal provisions at the applicable rate.

We reserve the right to adjust prices and shall charge the prices applying on the date of delivery.

All dimensions in this catalog/price list are in mm. The illustrations are for reference only.

We reserve the right to make changes, in particular to the specified values, dimensions and weights, unless specified otherwise on the individual pages of this catalog/price list.

Export regulations

The products listed in this catalog/price list may be subject to European/German and/or US export provisions.

Any export requiring approval is therefore subject to authorization by the relevant authorities.

For the products listed in this catalog/price list, the following export regulations must be adhered to in accordance with currently valid regulations.

AL	Number of the <u>German export list</u> Products with a code other than "N" must be approved for export. The export codes of the respective data medium must also be adhered to for software products. Goods labeled with " <u>AL not equal to N</u> " are subject to European or German export authorization when being exported out of the EU.
ECCN	Number of <u>US export list</u> (<u>Export Control Classification Number</u>) Products with a code other than "N" require approval for re-export to certain countries. The export codes of the respective data medium must also be adhered to for software products. Goods labeled with " <u>ECCN not equal to N</u> " are subject to US reexport authorization.

Even without a label, or with label "AL: N" or "ECCN: N", authorization may be required due to the final whereabouts and purpose for which the goods are to be used.

The AL and ECCN export codes specified in our confirmations, delivery notes and invoices apply.

Subject to change without prior notice.

A

Responsible for

Technical contents:
Siemens AG, A&D SD SM, Erlangen

General editing:
Siemens AG, A&D PT 5, Erlangen

Siemens AG
Automation & Drives
Standard Drives
Postfach 32 69
D-91050 Erlangen
Germany



Siemens Aktiengesellschaft

Automation and Drives

Standard Drives

Postfach 32 69, D-91050 Erlangen

www.siemens.com/micromaster