

# 110mm WIDE STILE HINGED DOOR

## TYPICAL CONFIGURATIONS

(APPLIES TO BOTH 100mm and 150mm  
FRAMING SYSTEMS)

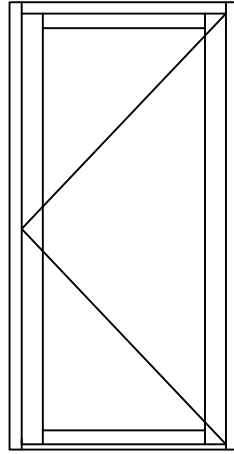
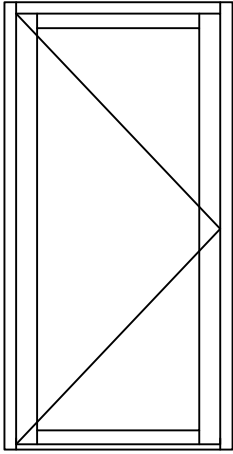

### LEFT HAND HINGED

- OPEN IN
- OPEN OUT

### RIGHT HAND HINGED

- OPEN IN
- OPEN OUT

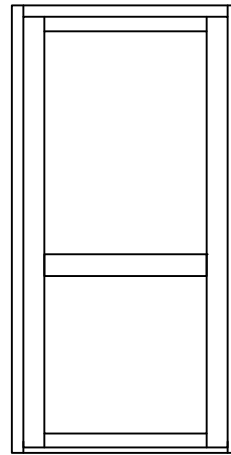

1 x MIDRAIL

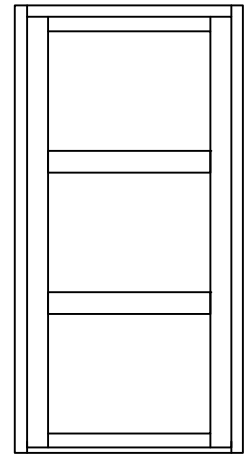

2 x MIDRAILS

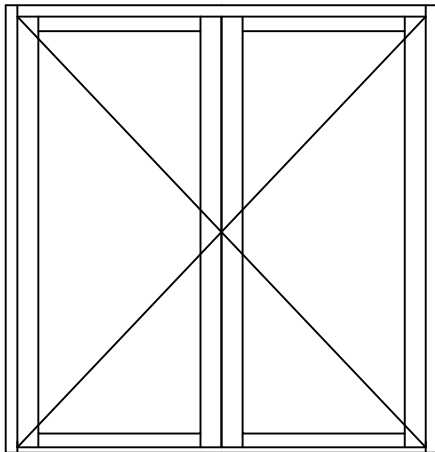

### DOUBLE PANEL HINGED DOORS

- OPEN IN
- OPEN OUT

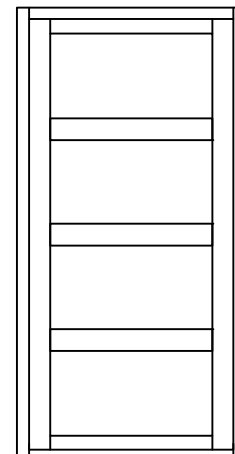

3 x MIDRAILS

**PATH 180**  
COMMERCIAL  
DOOR BEAD  
A/P: 142.44 mm  
L/W: 0.296 kg/m

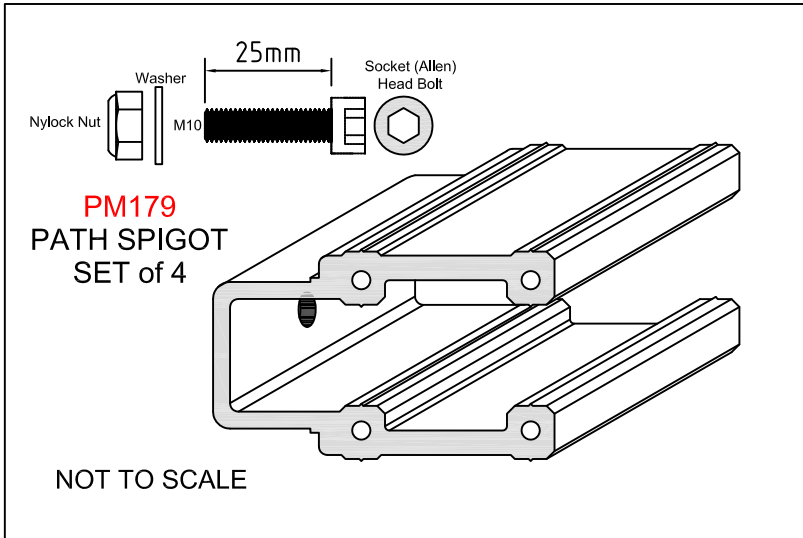
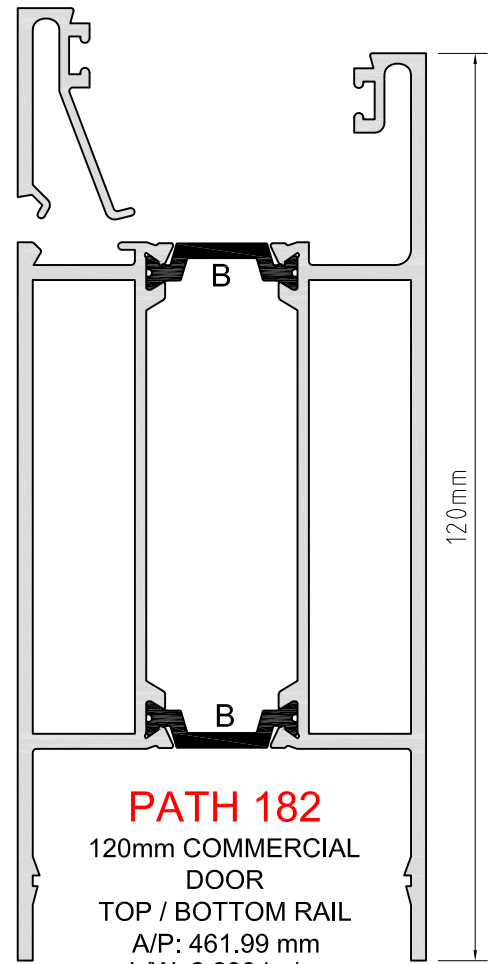

**PATH 182**  
120mm COMMERCIAL  
DOOR  
TOP / BOTTOM RAIL  
A/P: 461.99 mm  
L/W: 2.298 kg/m

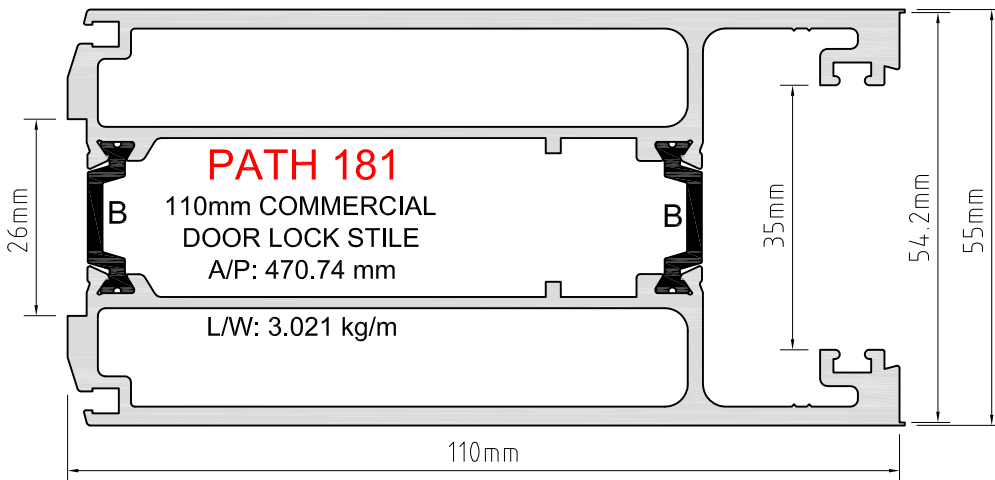

SCALE 1:1

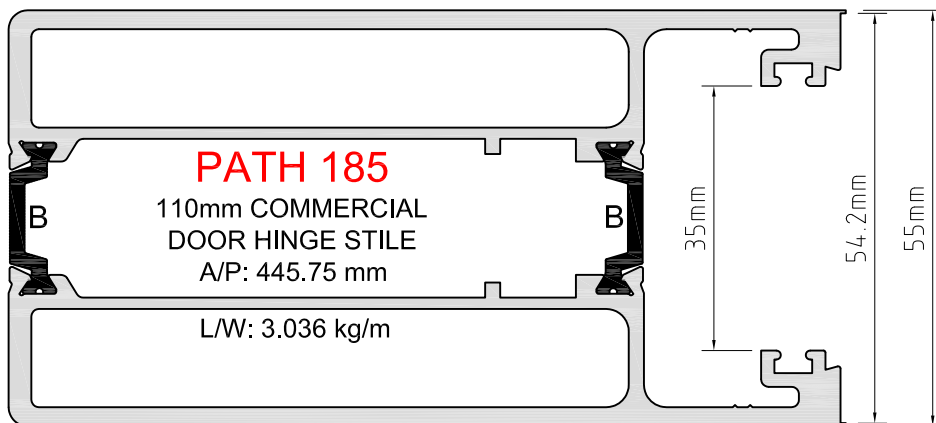

# EXTRUSIONS

HINGED DOOR

**rapid**  
ALUMINIUM

**PM 721**

UNIVERSAL DOOR  
STOP BEAD  
A/P: 77.61 mm  
L/W: 0.124 kg/m

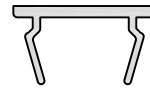

**PM 722**

UNIVERSAL DOOR  
STOP BASE  
A/P: 131.36 mm  
L/W: 0.255 kg/m

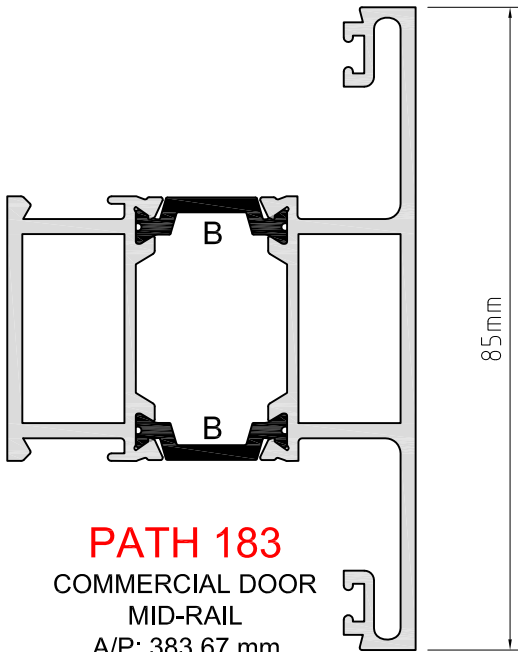
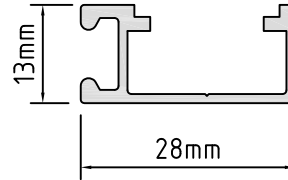

**PATH 183**

COMMERCIAL DOOR  
MID-RAIL  
A/P: 383.67 mm  
L/W: 1.654 kg/m

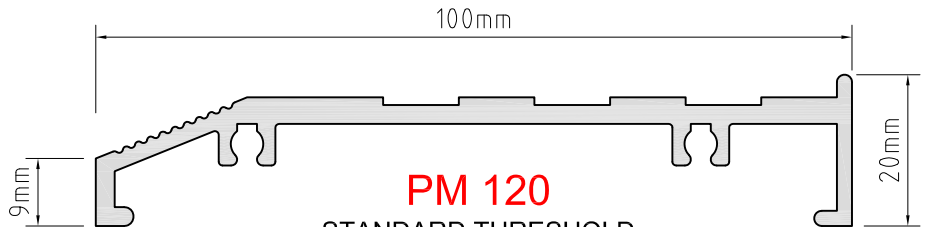

**PM 120**

STANDARD THRESHOLD  
A/P: 315.05 mm  
L/W: 1.098 kg/m

**PATH 143**

FRAME POCKET FILLER  
A/P: 132.82 mm  
L/W: 0.295kg/m

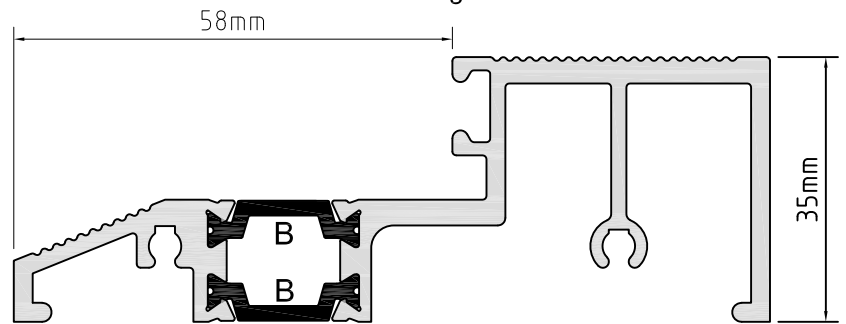
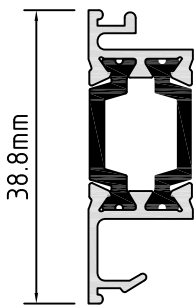

**PATH 184**

STEPPED THRESHOLD  
A/P: 479.63 mm  
L/W: 1.781 kg/m



**PM 021**  
DOOR STOP  
BULB SEAL

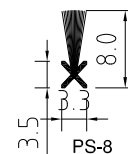

POLY-PILE PS SERIES

**path**

thermal break window system

# DETAILS

HINGED DOOR

**rapid**  
ALUMINIUM

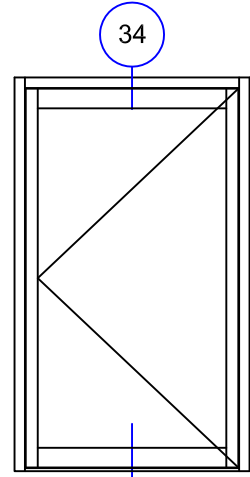
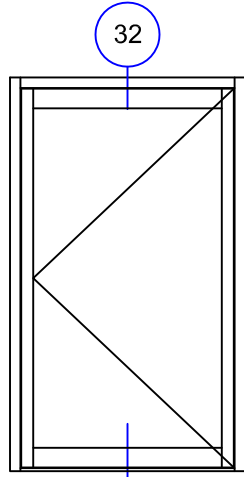

TYPICAL ELEVATIONS  
RIGHT HAND HINGED  
SCALE 1:2

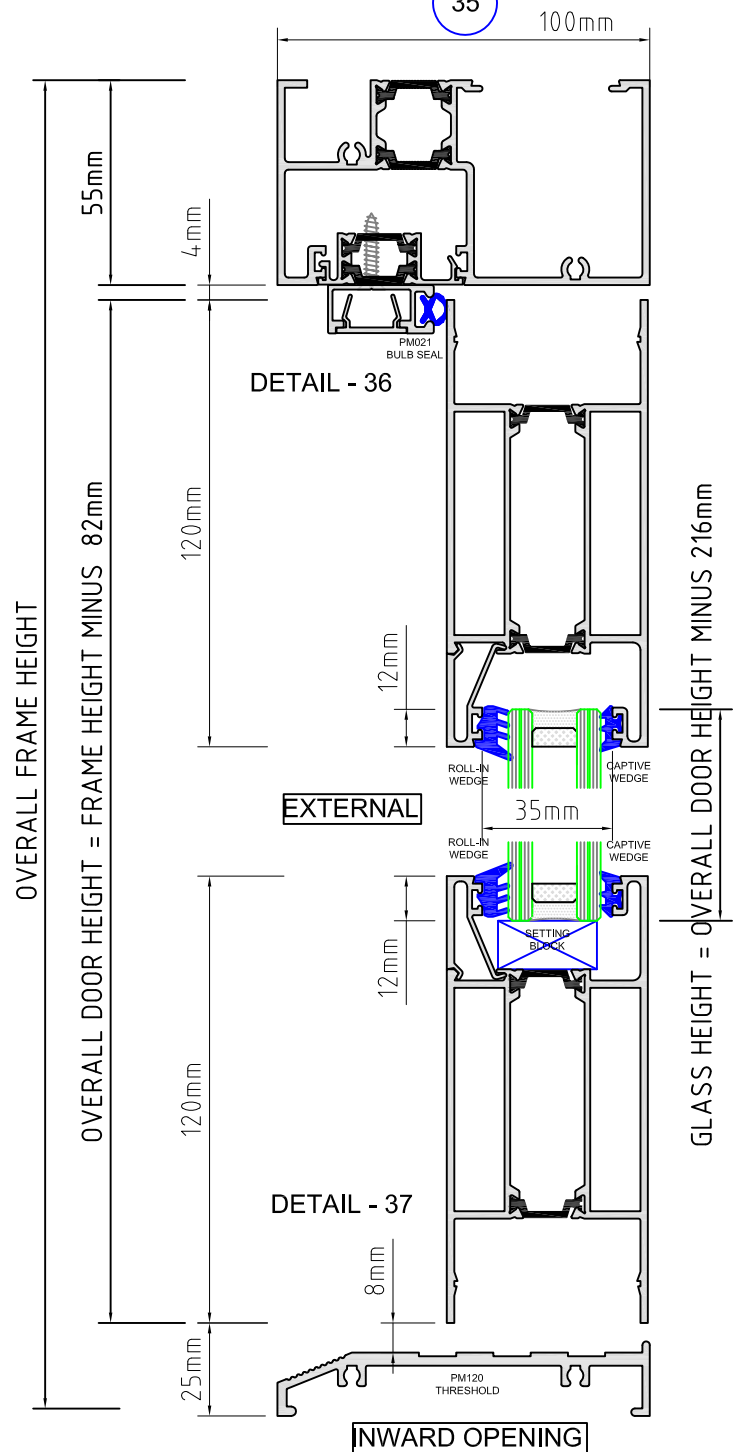
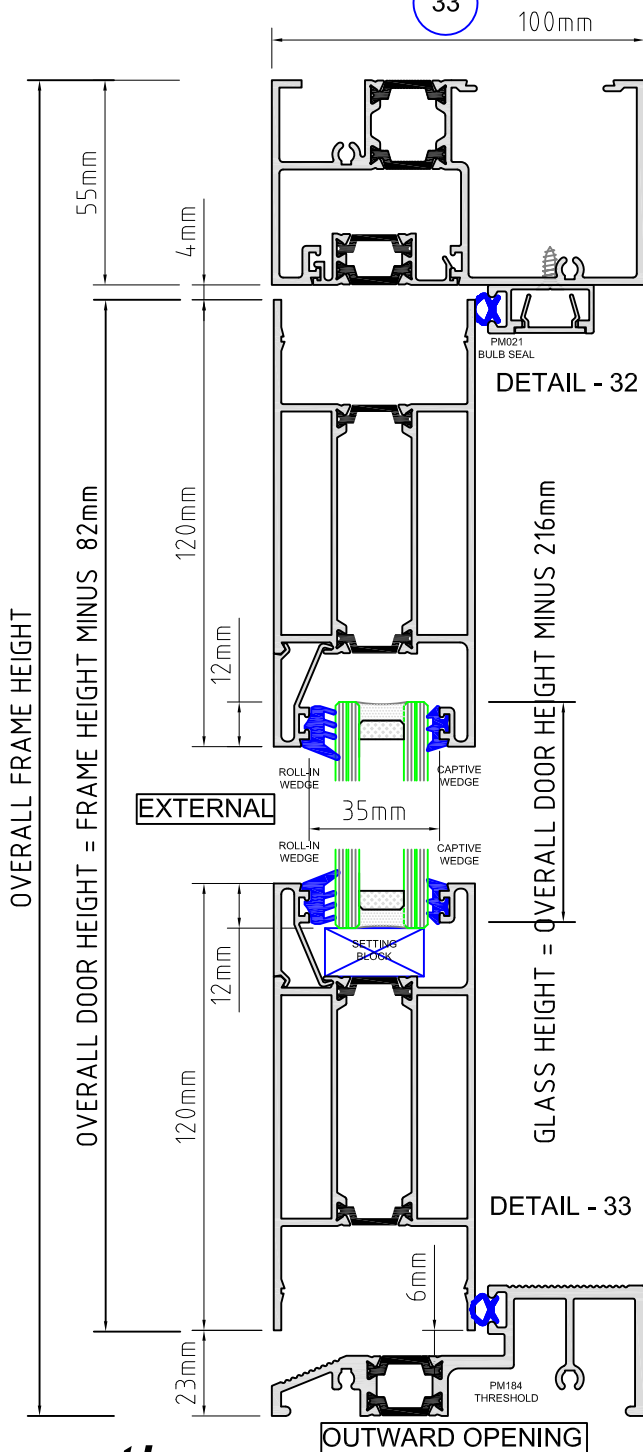

**path**

thermal break window system

# DETAILS

HINGED DOOR

**rapid**  
ALUMINIUM

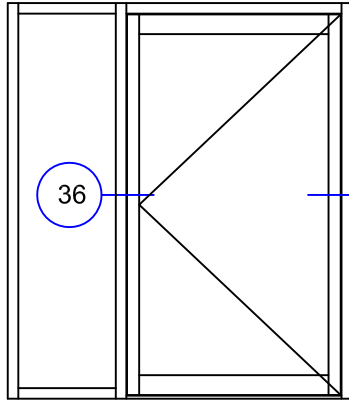

TYPICAL ELEVATIONS  
RIGHT HAND HINGED

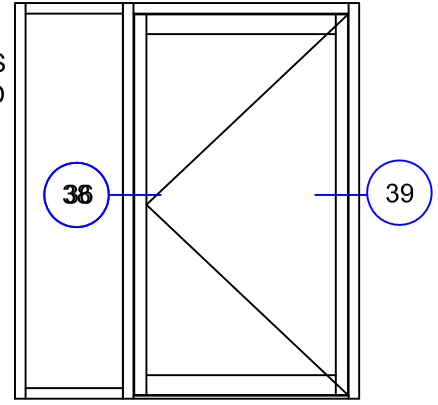

SCALE 1:2

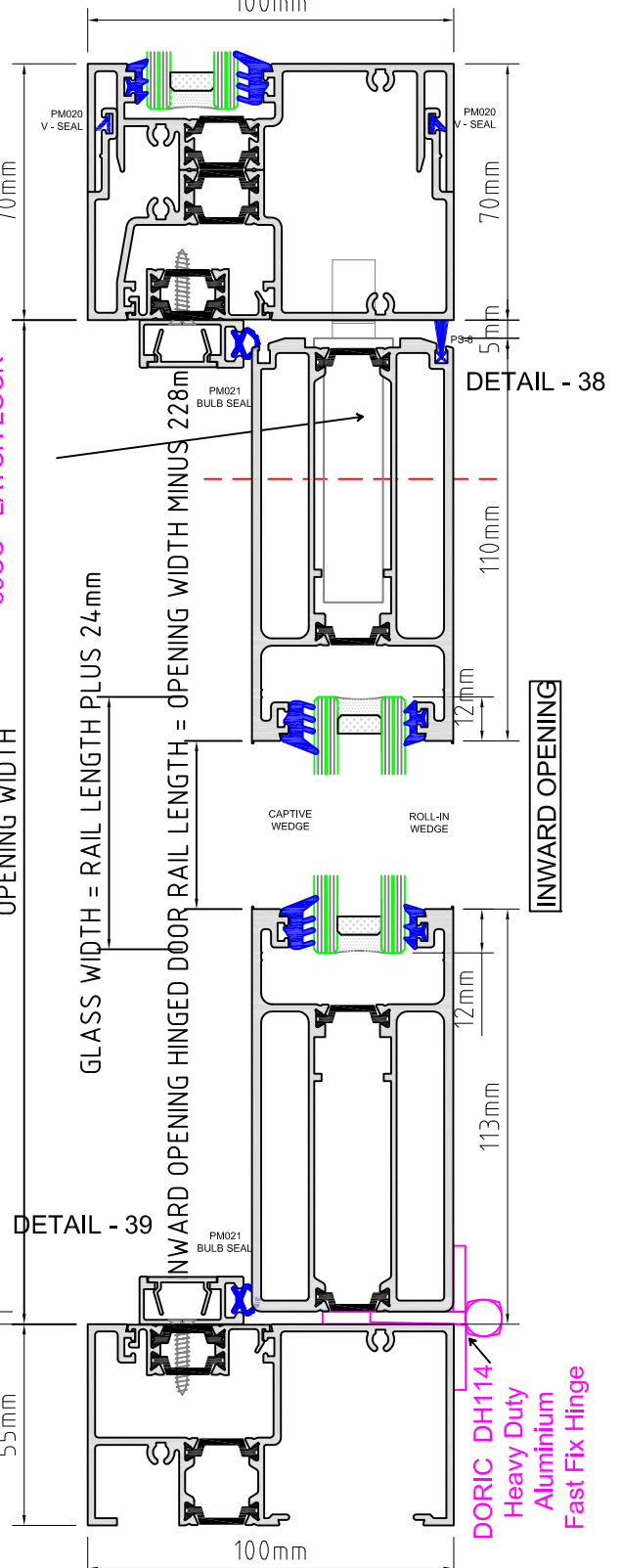
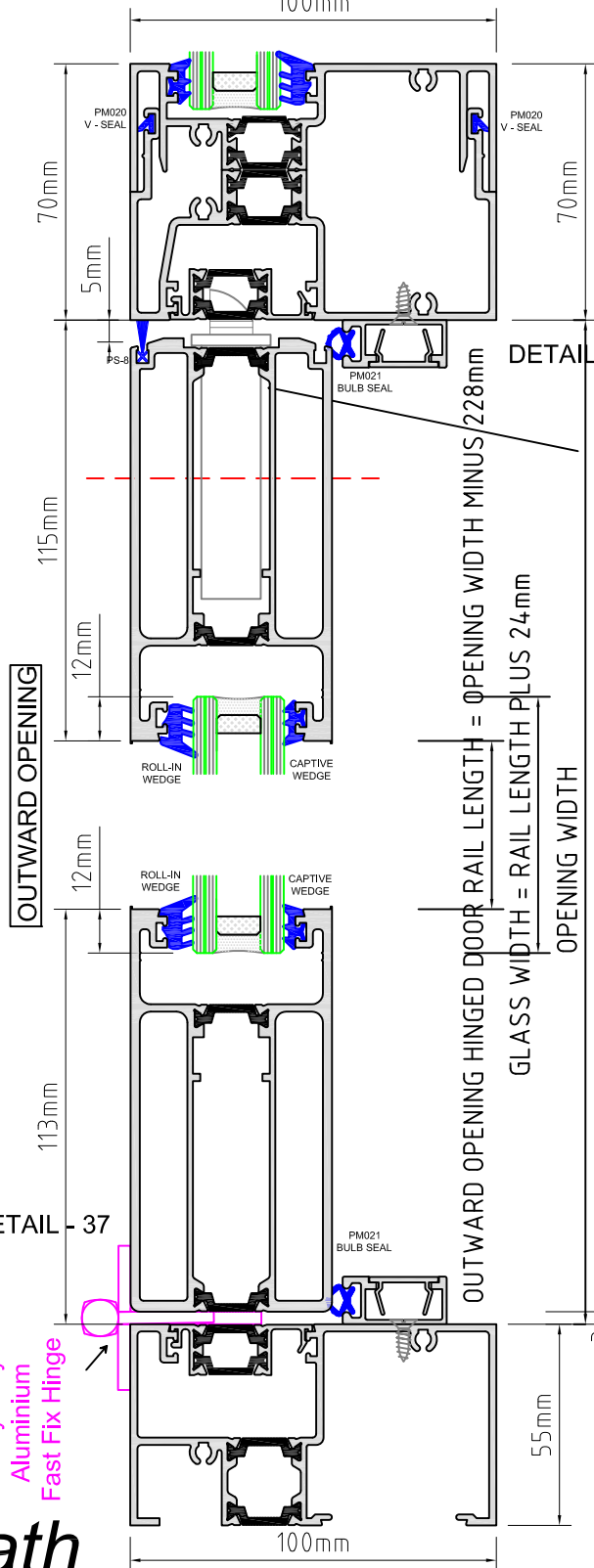

DORIC - DT20  
45mm BACKSET  
85CC - LATCH LOCK

DORIC DH114  
Heavy Duty  
Aluminum  
Fast Fix Hinge

DORIC DH114  
Heavy Duty  
Aluminum  
Fast Fix Hinge

**path**

thermal break window system

# DETAILS

HINGED DOOR

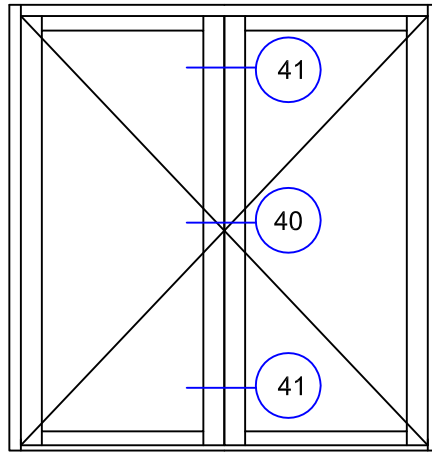

TYPICAL ELEVATIONS  
DOUBLE PANEL  
HINGED DOORS

SCALE 1:2

MORTICE LOCK  
DETAIL - 40

DORIC - DT20  
45mm BACKSET  
85CC - LATCH LOCK

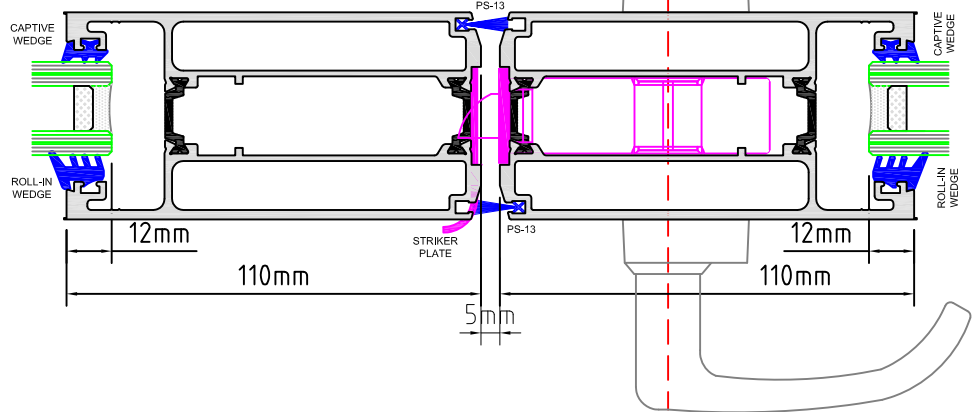

OUTWARD OPENING

DORIC - DN217  
FLUSHBOLT + STD  
250mm ROD

FLUSH BOLT  
DETAIL - 41

SCALE 1:2

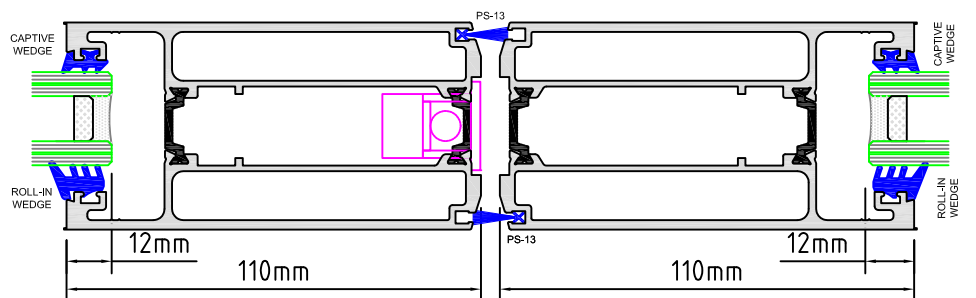

OUTWARD OPENING

*path*

thermal break window system

# DETAILS

HINGED DOOR

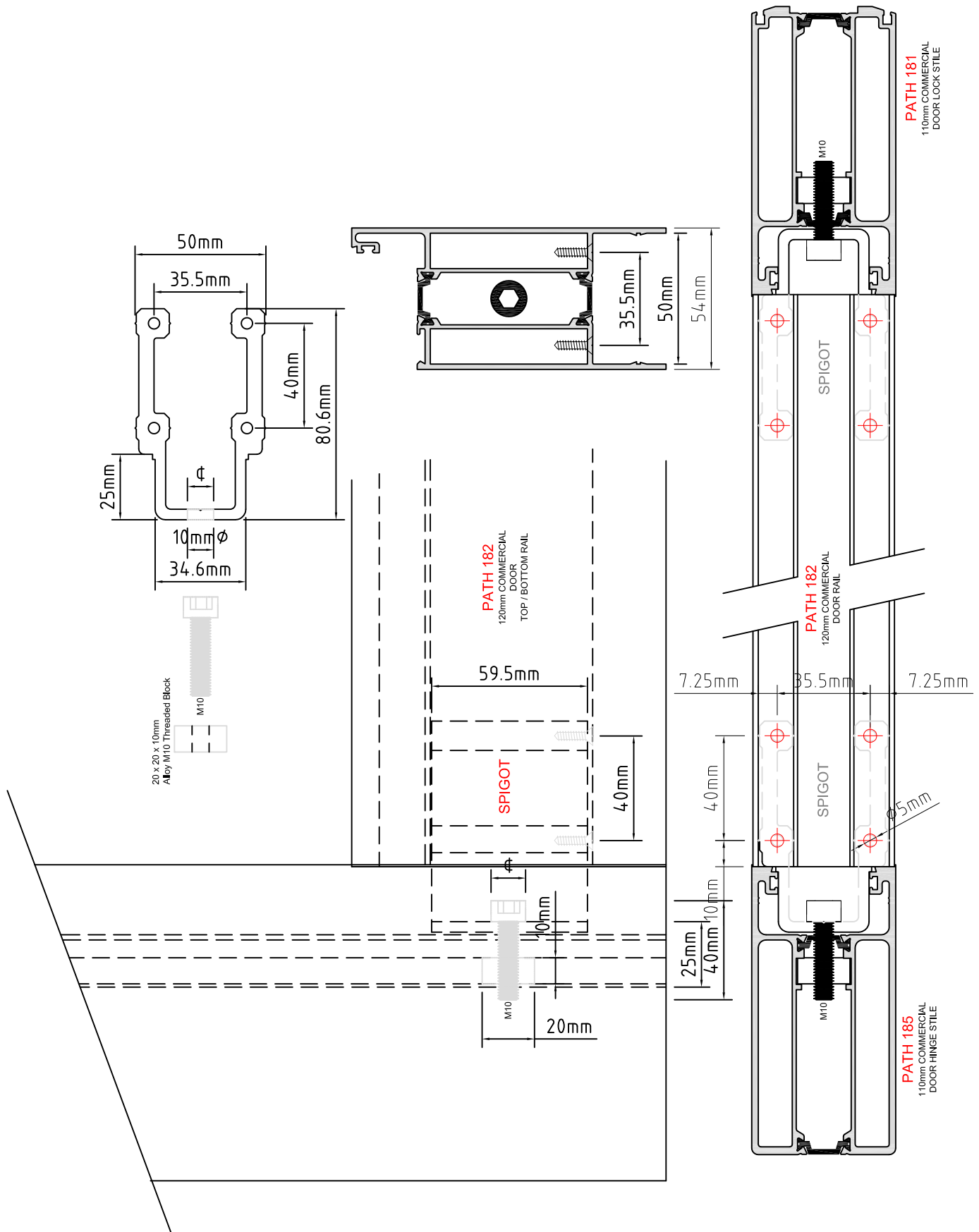

NOTES:

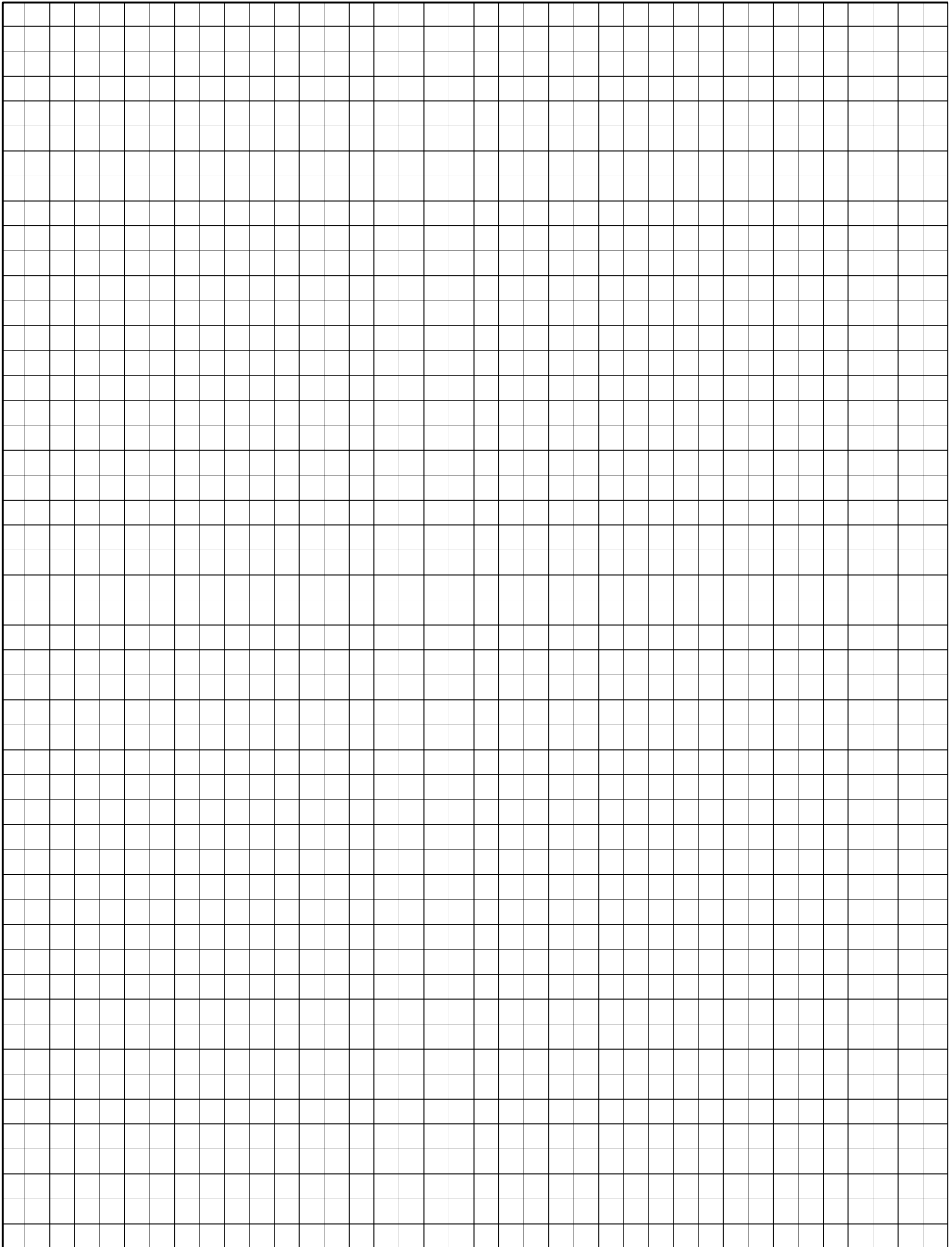

*path*

thermal  break window system